

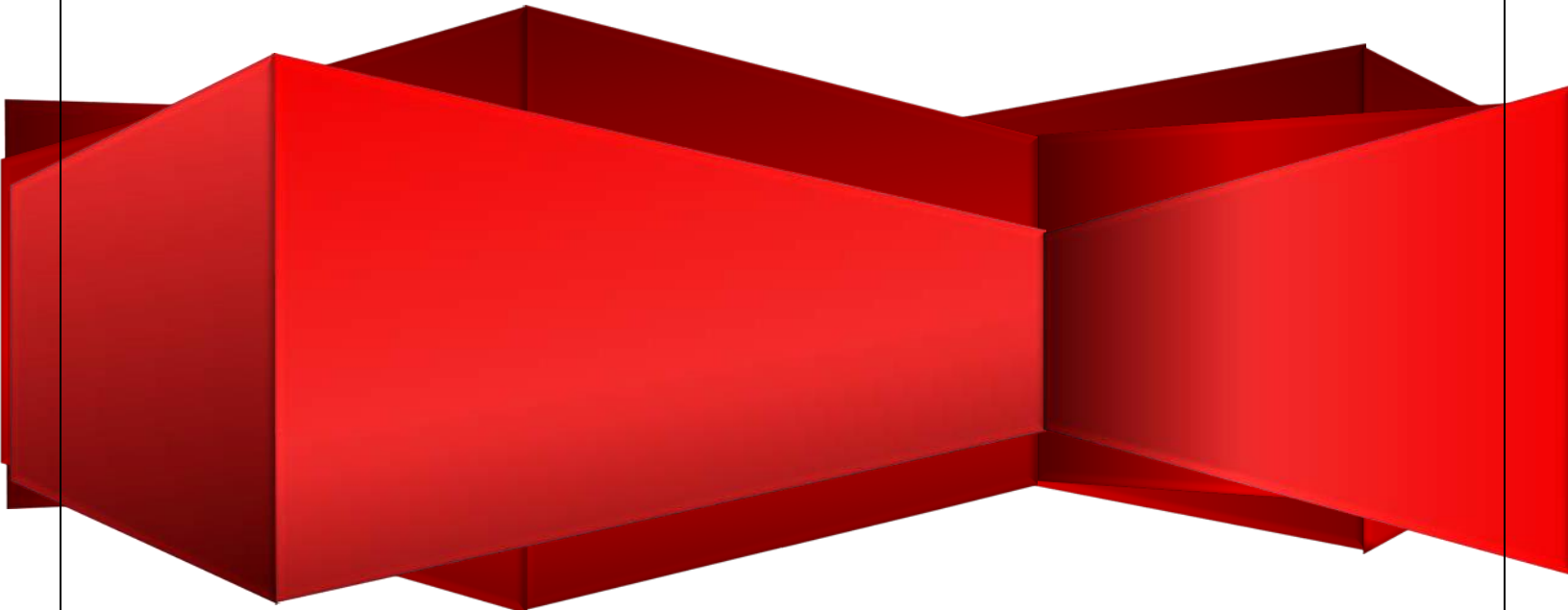

**Integrate Assembly
Instructions**



Integrate Assembly Instructions

TABLE OF CONTENTS

1) Bookcase (I3BK)(PARTS)	Rev 0, 6/10/2014
2) Bridge, U-Unit 42 Inch (IK42BR).....	Rev 0, 6/10/2014
3) Bridge, U-Unit 48 Inch (IK48BR).....	Rev 0, 6/10/2014
4) Conference End (IK48CEP) Rev 0, 6/10/2014.....	Rev 0, 6/10/2014
5) Credenza Base Double Door (I36CBCS & I36CBCW)(PARTS).....	Rev 0, 6/10/2014
6) Credenza Base Single Door (I16CBCS & I16CBCW) (PARTS).....	Rev 0, 6/10/2014
7) Credenza Mixed Drawer Box-Box Left (I36CBMS & I36CBMW)(PARTS).....	Rev 0, 6/10/2014
8) Credenza Mixed Drawer Box-Box Right (I36CBMS & I36CBMW)(PARTS).....	Rev 0, 6/10/2014
9) Credenza, Shell 60 Inch (I60CRSH).....	Rev 0, 6/10/2014
10) Credenza, Shell 72 Inch (I60CRSH).....	Rev 0, 6/10/2014
11) Credenza, Shell 42”with Removable Access Panel (I42CRSHAP).....	Rev 0, 4/11/2018
12) Desk, Shell 42”with Removable Access Panel (I42DKSHAP).....	Rev 0, 4/11/2018
13) Desk, Shell 60”with Removable Access Panel (I60DKSHAP).....	Rev 0, 4/11/2018
14) Desk, Shell 72”with Removable Access Panel (I72DKSHAP).....	Rev 0, 4/11/2018
15) Desk, Double Pedestal 60 Inch (I60DKDP).....	Rev 0, 6/10/2014
16) Desk, Double Pedestal 72 Inch (I72DKDP).....	Rev 0, 6/10/2014
17) Desk, Shell 60 Inch(I60DKSH).....	Rev 0, 6/10/2014
18) Desk, Shell 72 Inch(I72DKSH).....	Rev 0, 6/10/2014
19) Desk, Single Pedestal File-File, 60 Inch (I60DKSP).....	Rev 0, 6/10/2014
20) Desk, Single Pedestal File-File, 72 Inch (I72DKSP).....	Rev 0, 6/10/2014
21) Desk, Single Pedestal Pencil-Drawer-File, 60 Inch (I60DKSP).....	Rev 0, 6/10/2014
22) Desk, Single Pedestal Pencil-Drawer-File, 72 Inch (I72DKSP).....	Rev 0, 6/10/2014
23) Extension, L-Unit 42 Inch (IK42EX).....	Rev 0, 6/10/2014
24) Extension, L-Unit 48 Inch (IK48EX).....	Rev 0, 6/10/2014
25) Lateral File 2-Drawer (I2LFS & I2LFW).....	Rev 0, 6/10/2014
26) Lateral File 2-Drawer (I2LFS & I2LFW)(PARTS).....	Rev 0, 6/10/2014
27) Lateral File 3-Drawer (I3LFS)(PARTS).....	Rev 0, 6/10/2014
28) Overhead 60 Inch (I60OHCFB)(PARTS).....	Rev 0, 6/10/2014
29) Overhead 72 Inch (I72OHCFB)(PARTS).....	Rev 0, 6/10/2014
a. Overhead attachment instructions.....	Rev 0, 8/15/2014
30) Pedestal 24 Inch File-File (I24PDF and I24PDW)(PARTS).....	Rev 0, 6/10/2014
31) Pedestal 24 Inch Pencil-Box-File (I24PDF and I24PDW)(PARTS).....	Rev 0, 6/10/2014
32) Side Shelving 24 Inch (I24SS)(PARTS).....	Rev 1 8/15/2014
33) Storage Cabinet (I1867SCC)(PARTS).....	Rev 0, 6/10/2014
34) Upper Shelving Unit 16 Inch Closed (I16USC)(PARTS).....	Rev 0, 6/10/2014
35) Upper Shelving Unit 16 Inch Open (I16USO)(PARTS).....	Rev 0, 6/10/2014
36) Upper Shelving Unit 36 Inch Closed (I36USC)(PARTS).....	Rev 0, 6/10/2014
37) Upper Shelving Unit 36 Inch Open (I36USO)(PARTS).....	Rev 0, 6/10/2014
38) Wardrobe, Compact (I1854WR).....	Rev 0, 6/10/2014
39) Wardrobe, Standard (I1867WR)(PARTS).....	Rev 0, 6/10/2014



Revision Log

8/15/2014 Item 28 Sided Shelving, Added Rev 1 8/15, The revision added a section showing how to attach the side shelving unit

8/15/2014 Item 25 a. was added. New document shows how to attach an upper to a worksurface

Integrate Assembly Instructions
Bookcase 3-Shelf
(Part No. I3BK)

Note

-  Mount Toe-Kick flush with top of Bottom Panel
-  Space Cleats evenly on the front and the back edge of Bottom Panel

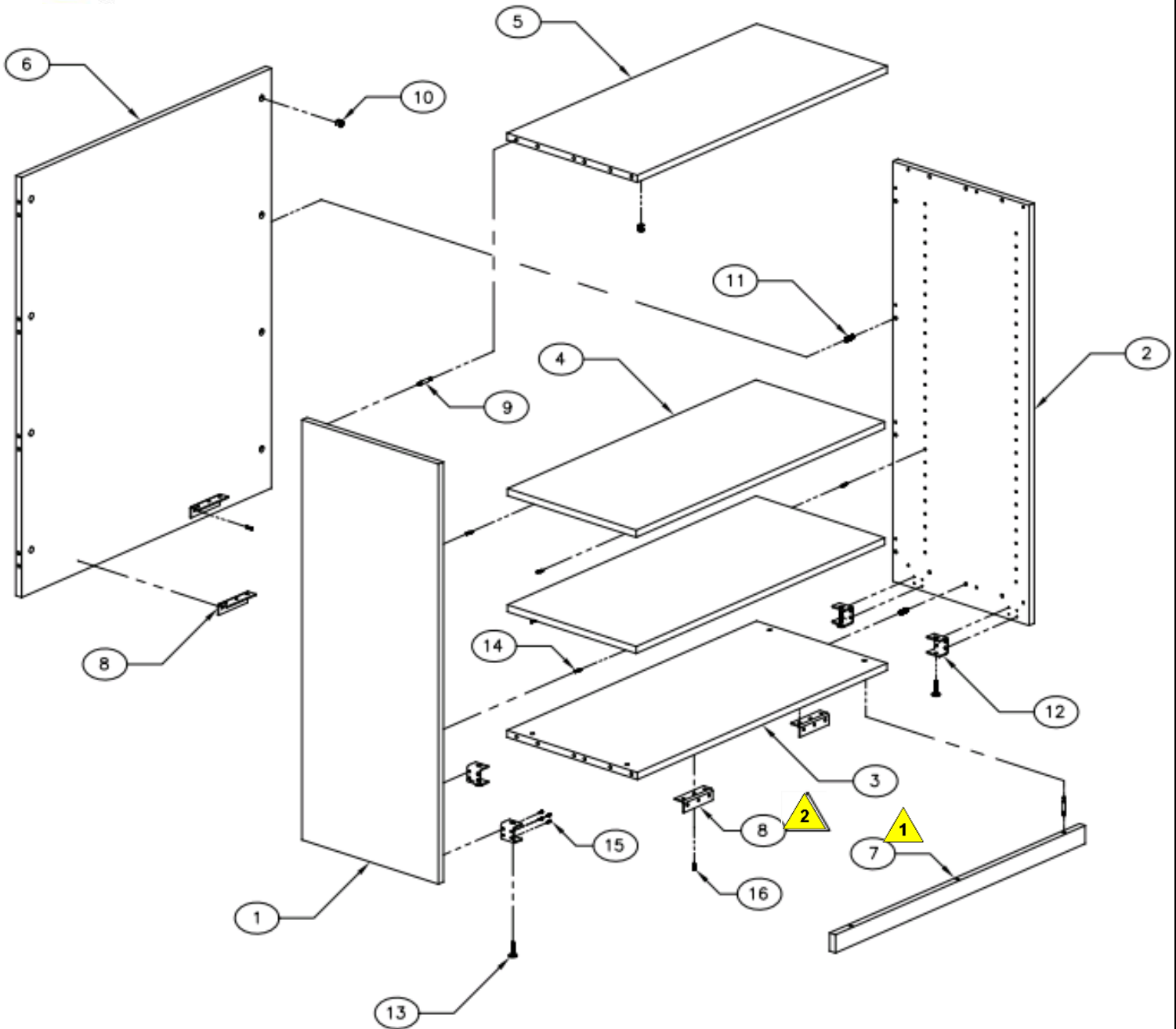

Integrate Assembly Instructions
Bookcase 3-Shelf
(Part No. I3BK)



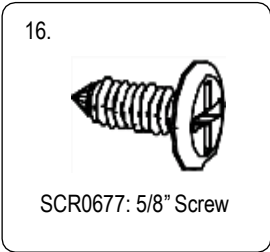
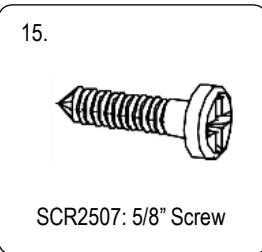
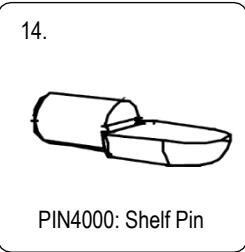
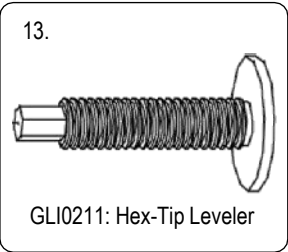
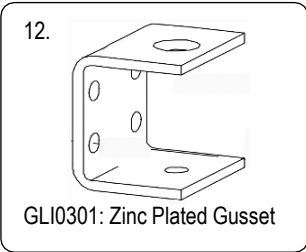
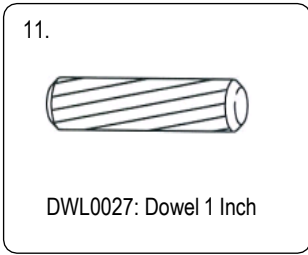
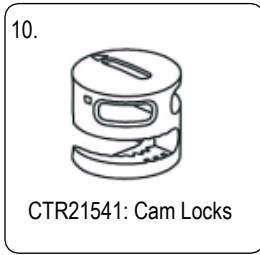
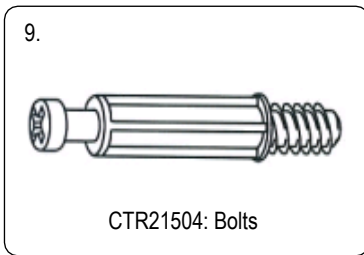
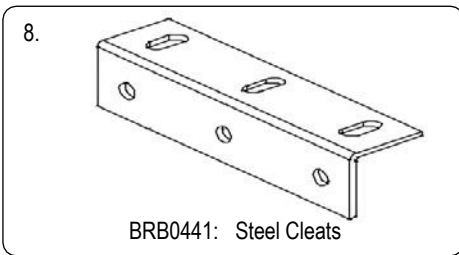



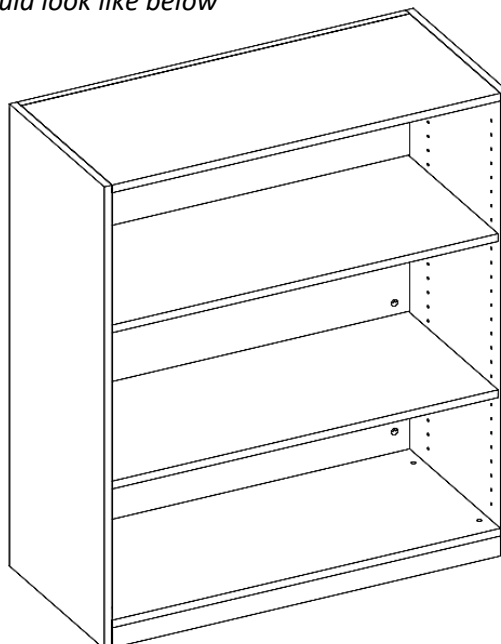

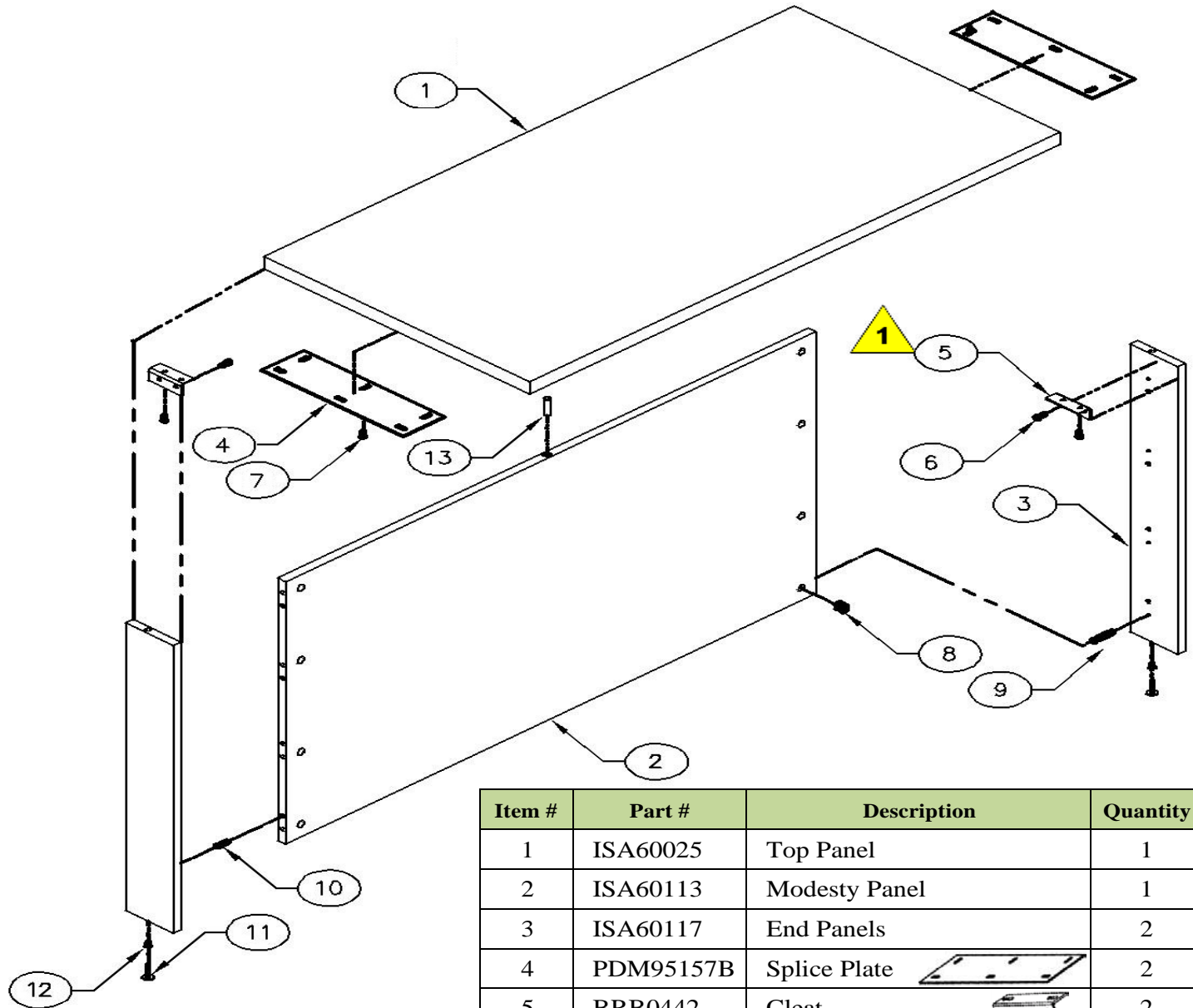
Item #	Part #	Description	Quantity
1	ISA70005	Left End Panel	1
2	ISA70007	Right End Panel	1
3	ISA70009	Bottom Panel	1
4	ISA70011	Shelf Panel	2
5	ISA70013	Top Interior Panel	1
6	ISA70015	Back Panel	1
7	ISA70017	Toe Kick Panel	1

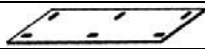

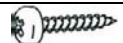

Your Final Assembled Product should look like below





Item #	Part #	Description	Quantity
1	ISA60025	Top Panel	1
2	ISA60113	Modesty Panel	1
3	ISA60117	End Panels	2
4	PDM95157B	Splice Plate 	2
5	BRB0442	Cleat 	2
6	SCR2507	Screw 5/8 Inch 	8
7	SCR0681	Screw 3/4 Inch 	12
8	CTR21541	CamLocks 	8
9	CTR21504	Bolt, 7mm Dia. 	8
10	DWL0027	Wood Dowel 	8
11	GLI0212	Hex-Base Glides 	2
12	GLI0191	Insert Nuts for Glides 	2
13	SPC4898	Spacer 	1

Warnings

-  Do not over-tighten the screws.
-  Do not turn cam-locks more than 180°.

Note

-  Space Cleats Evenly at top edge of inside face of panel
- Assembly should be performed on a clean flat floor.
- Verify all items are received before assembling.

Tools

- #2 Phillips Screwdriver
- 5mm wrench

STEP 1: ATTACH CLEATS TO THE END PANELS

Locate the two cleats (Item 5) at top corner of inside face of each End Panel (Item 3) and fasten it with the Screws (Item 6) in the holes provided. (See Fig. 1)

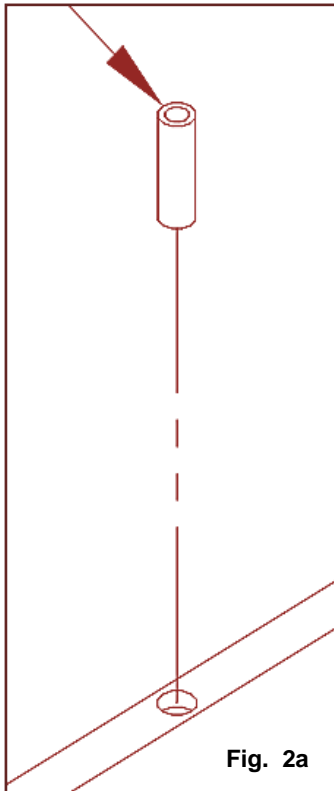

Fig. 2a

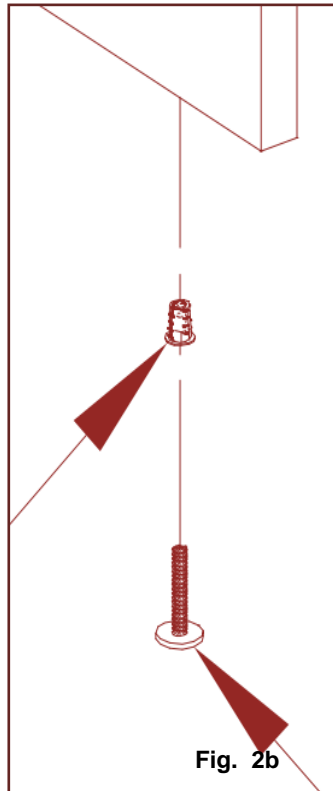

Fig. 2b

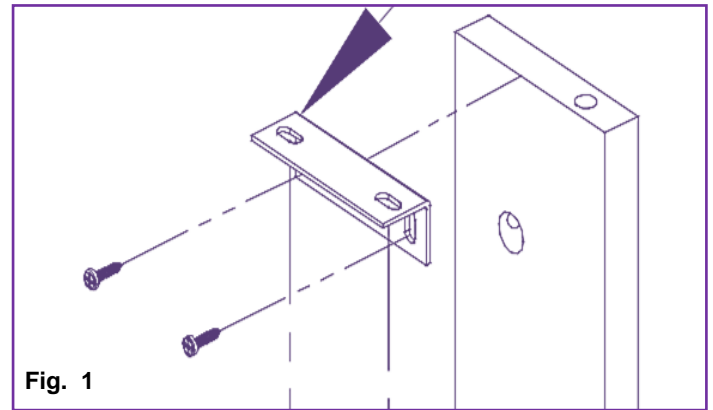

Fig. 1

STEP 2: INSERT GLIDES AND SPACER TO PANELS

Insert one Glide Nuts (Item 12) each in the holes provided at the bottom edges on the End panels and Screw the Hex-Base Glides (Item 11) each in the Glide Nut. (See Figure 2b).

Insert the Spacer (item 13) in the hole provided on the top of the Modesty panel (Item 2). (See Figure 2a).

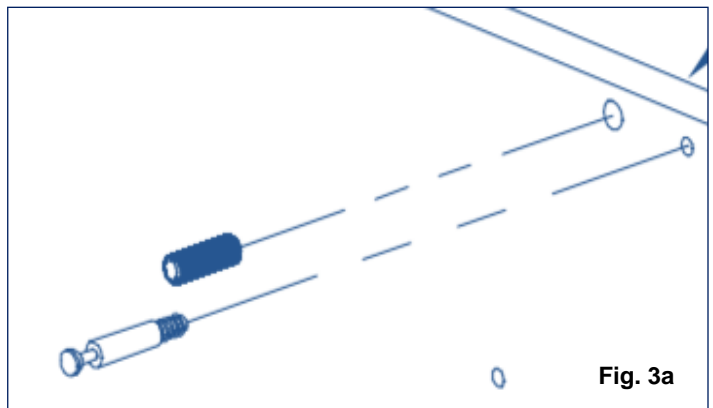

Fig. 3a

STEP 3: INSERT BOLTS, DOWELS AND CAM-LOCKS TO PANELS

Insert 8 cams (Item 8) in the holes provided on the Modesty Panel (item 2) (See Fig. 3b). Insert 4 wood dowels (Item 10) and screw 4 Connecting Bolts (Item 9) each in the holes provided on both the End panels (item 3)(See Figure 3a).

Place the End panels at right angles on the Modesty Panel so that the Dowels and Bolts are inserted into the pre-drilled holes on the edge of the panels.

Twist-lock all the 8 cams with a Philips screw-driver to the Connecting bolts on the panels.

Your Base of the unit along with Modesty Panel should be assembled with cleats on the top of the end panels.

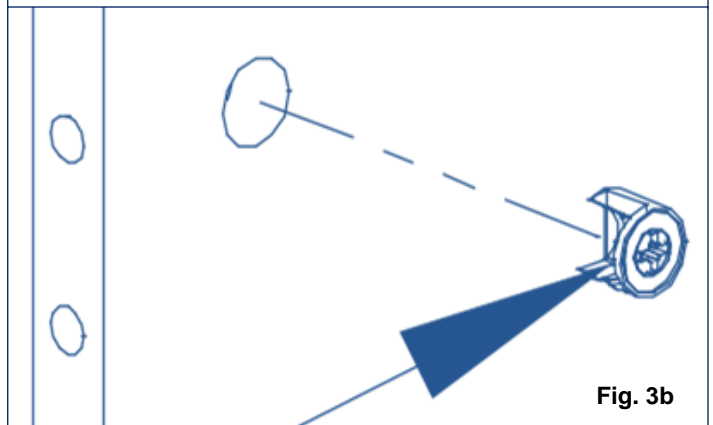
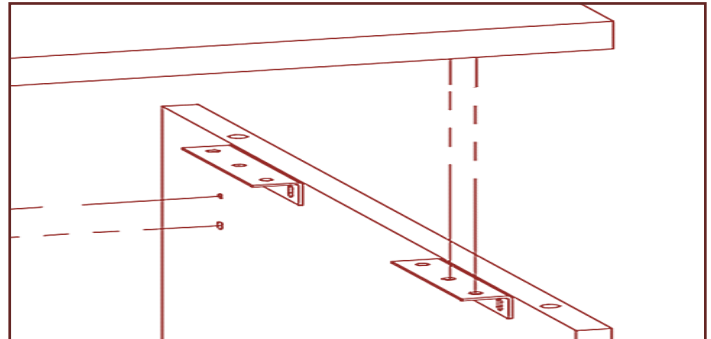

Fig. 3b

STEP 4: ATTACH THE TOP PANEL

Place the Top Panel (Item 1) on a flat surface and attach the two Splice Plates (Item 4) with Screws (Item 7) to both the left and right side of the Top panel. These two Splice Plates will also attach the U-Unit Bridge to the Worksurfaces on left and right.







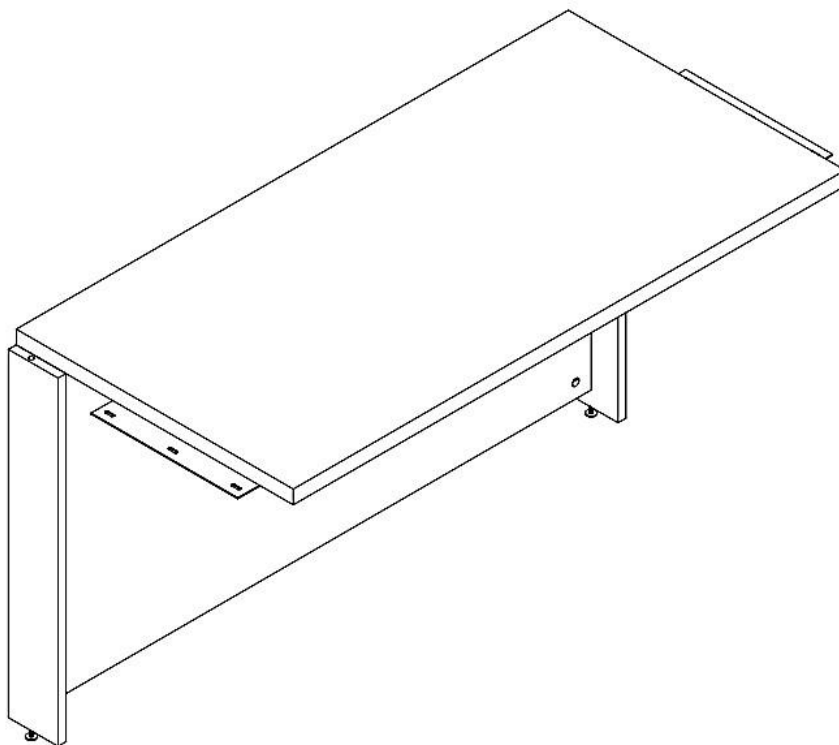

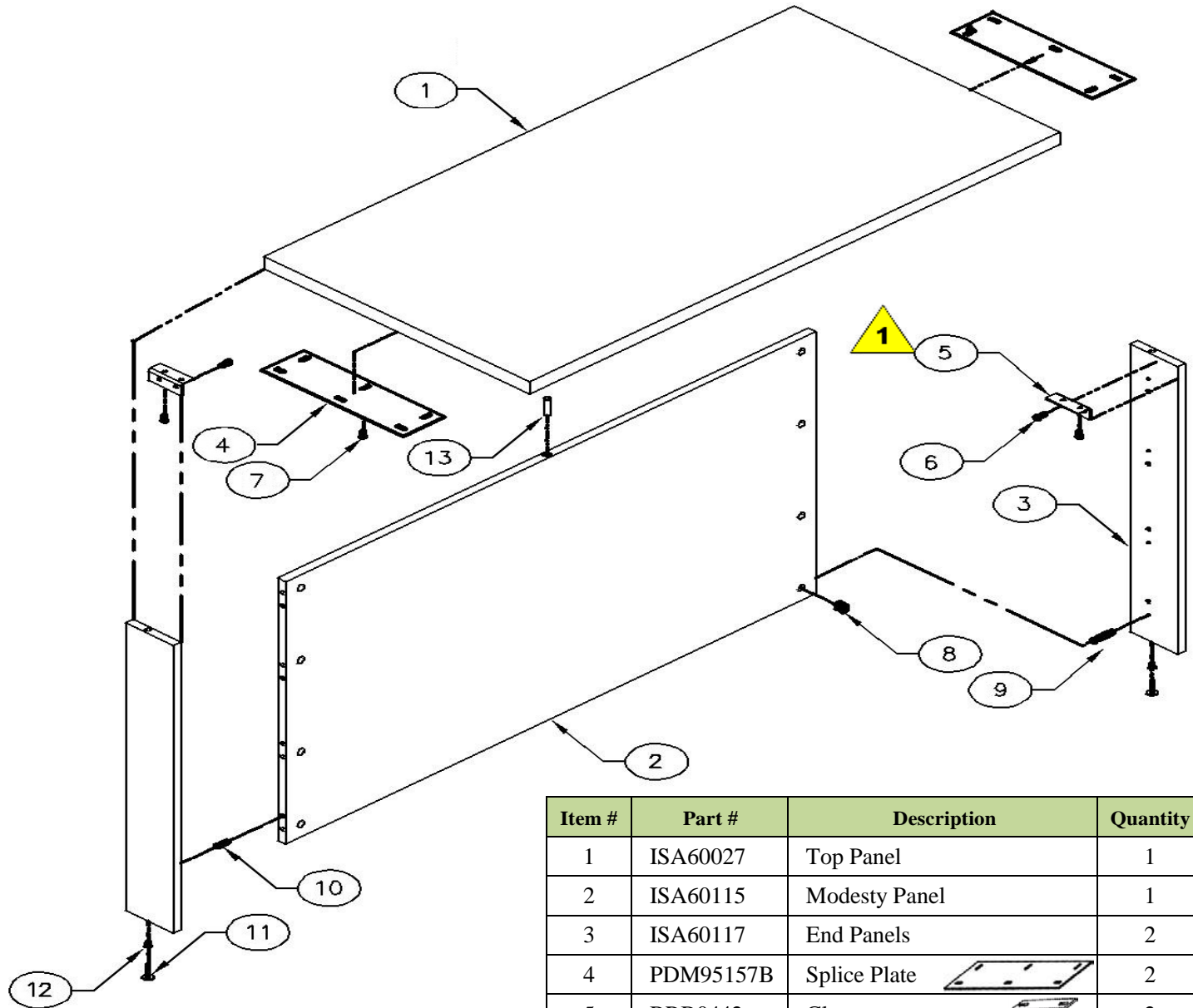

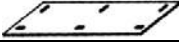
Attach the top panel to the base assembly with screws (Item 6) to the steel cleats (previously fastened on the top of End panels) (See Figure 4). Locate Top flush with back and outer edges of End panels.





Your Final Assembled Product should look like below:





Item #	Part #	Description	Quantity
1	ISA60027	Top Panel	1
2	ISA60115	Modesty Panel	1
3	ISA60117	End Panels	2
4	PDM95157B	Splice Plate 	2
5	BRB0442	Cleat 	2
6	SCR2507	Screw 5/8 Inch 	8
7	SCR0681	Screw 3/4 Inch 	12
8	CTR21541	CamLocks 	8
9	CTR21504	Bolt, 7mm Dia. 	8
10	DWL0027	Wood Dowel 	8
11	GLI0212	Hex-Base Glides 	2
12	GLI0191	Insert Nuts for Glides 	2
13	SPC4898	Spacer 	1

Warnings

-  Do not over-tighten the screws.
-  Do not turn cam-locks more than 180°.

Note

 Space Cleats Evenly at top edge of inside face of panel

- Assembly should be performed on a clean flat floor.
- Verify all items are received before assembling.

Tools

- #2 Phillips Screwdriver
- 5mm wrench

STEP 1: ATTACH CLEATS TO THE END PANELS

Locate the two cleats (Item 5) at top corner of inside face of each End Panel (Item 3) and fasten it with the Screws (Item 6) in the holes provided. (See Fig. 1)

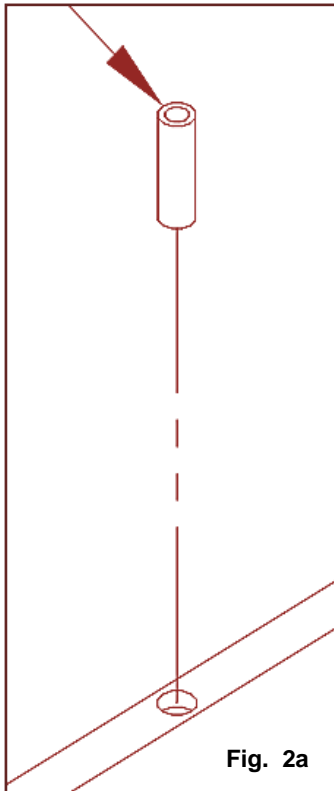

Fig. 2a

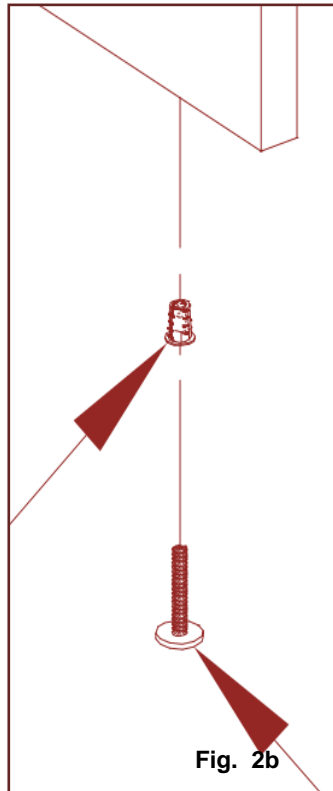

Fig. 2b

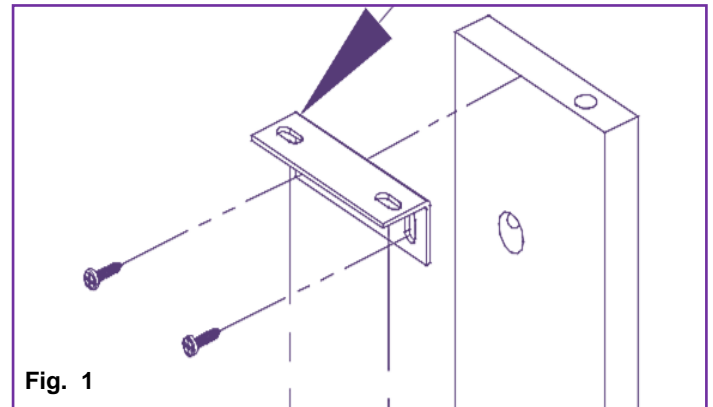

Fig. 1

STEP 2: INSERT GLIDES AND SPACER TO PANELS

Insert one Glide Nuts (Item 12) each in the holes provided at the bottom edges on the End panels and Screw the Hex-Base Glides (Item 11) each in the Glide Nut. (See Figure 2b).

Insert the Spacer (item 13) in the hole provided on the top of the Modesty panel (Item 2). (See Figure 2a).

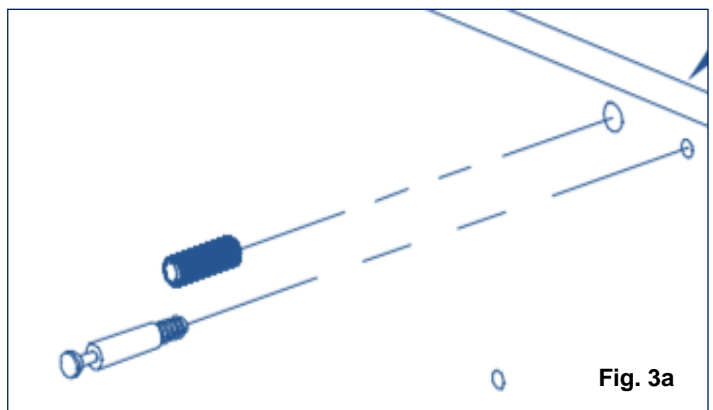

Fig. 3a

STEP 3: INSERT BOLTS, DOWELS AND CAM-LOCKS TO PANELS

Insert 8 cams (Item 8) in the holes provided on the Modesty Panel (item 2) (See Fig. 3b). Insert 4 wood dowels (Item 10) and screw 4 Connecting Bolts (Item 9) each in the holes provided on both the End panels (item 3)(See Figure 3a).

Place the End panels at right angles on the Modesty Panel so that the Dowels and Bolts are inserted into the pre-drilled holes on the edge of the panels.

Twist-lock all the 8 cams with a Philips screw-driver to the Connecting bolts on the panels.

Your Base of the unit along with Modesty Panel should be assembled with cleats on the top of the end panels.

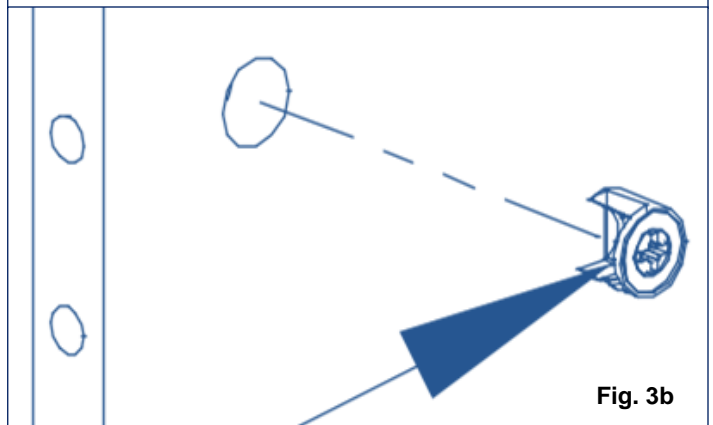
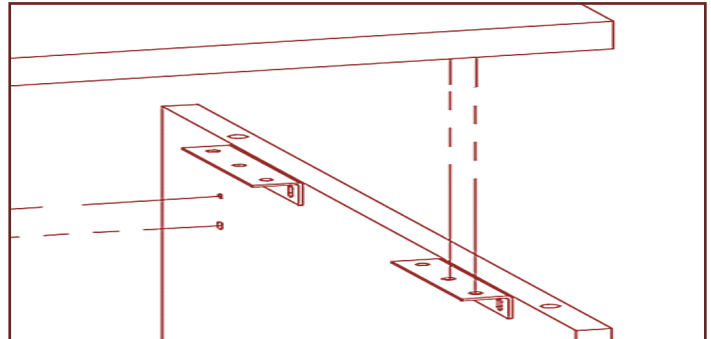

Fig. 3b

STEP 4: ATTACH THE TOP PANEL

Place the Top Panel (Item 1) on a flat surface and attach the two Splice Plates (Item 4) with Screws (Item 7) to both the left and right side of the Top panel. These two Splice Plates will also attach the U-Unit Bridge to the Worksurfaces on left and right.

Attach the top panel to the base assembly with screws (Item 6) to the steel cleats (previously fastened on the top of End panels) (See Figure 4). Locate Top flush with back and outer edges of End panels.



Your Final Assembled Product should look like below:

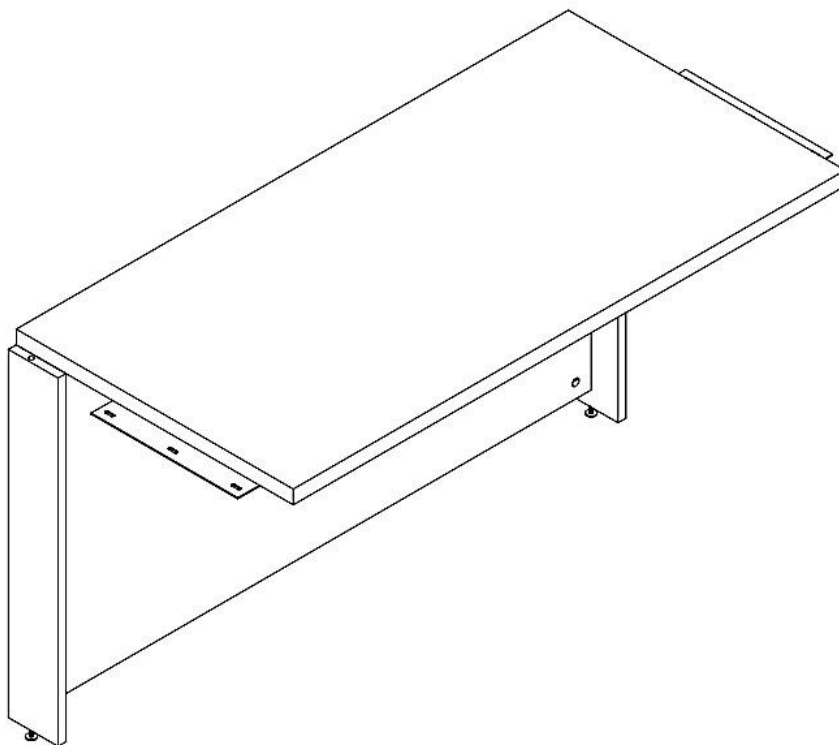

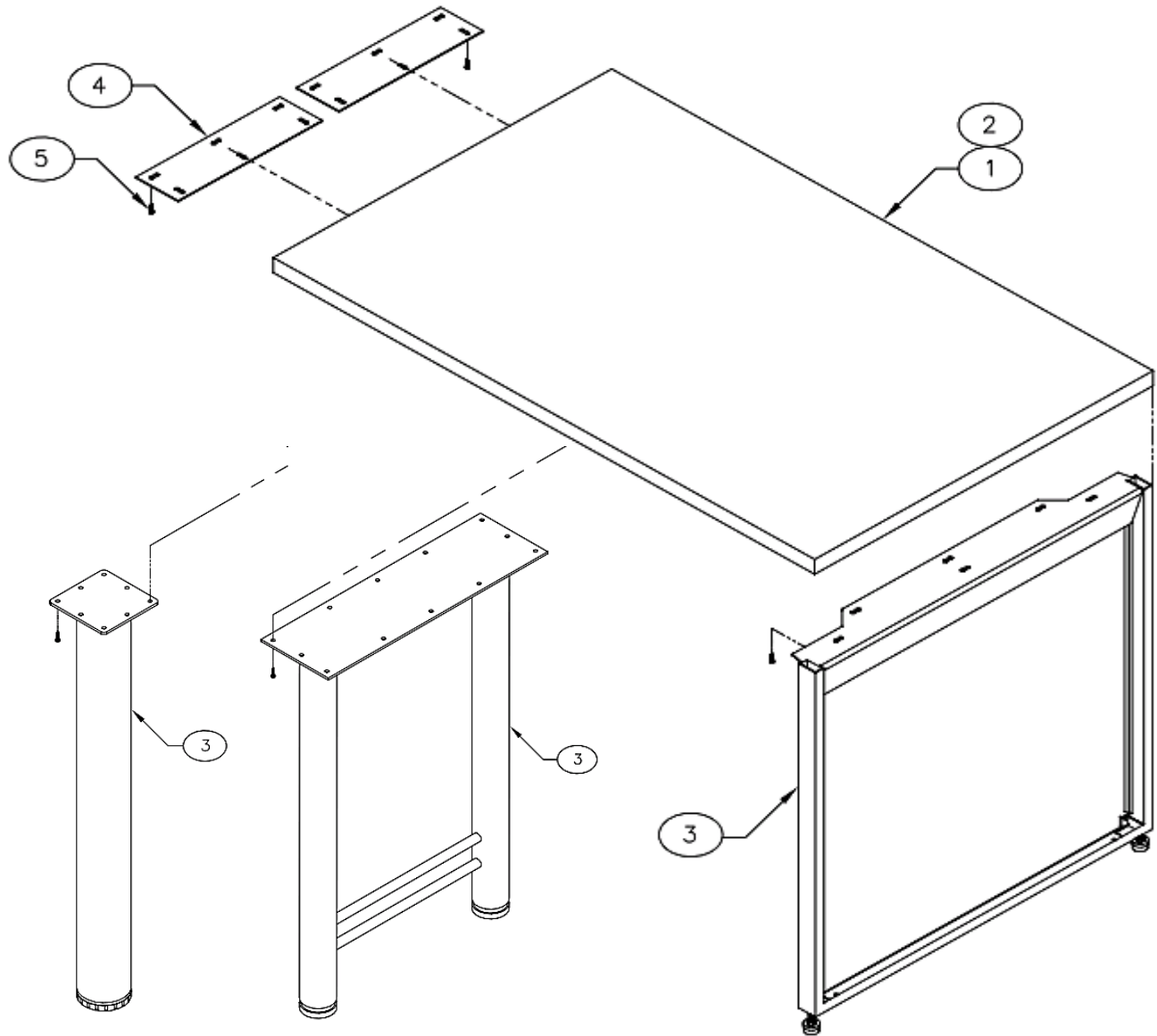

Warnings



-  Do not over-tighten the screws.
- Do not turn cam-locks more than 180°.

Note

- Assembly should be performed on a clean flat floor.
- Verify all items are received before assembling.

Tools

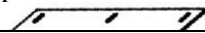
- #2 Phillips Screwdriver
- 5mm wrench

Item #	Part #	Description	Quantity
1	ISA60221	Top Panel Hardware Location	1
2	ISA60223	Top Panel (for 3" Column)	1
2	ISA60225	Top Panel (for H-Leg 450)	1
2	ISA60227	Top Panel (for Panel Leg)	1
3	PDM95156SX	Leg 3" Column	1
3	HLEGSTSILVER	H-Leg 450	1
4	PDM95157B	Splice Plate 	2
5	SCR0681	Screw 7/8 Inch 	20

STEP 1: ATTACH SPLICE PLATES TO THE TOP PANEL

Evenly Space the two Splice Plates (Item 4) at bottom of Top Panel (Item 2) and fasten it with the Screws (Item 5) in the holes provided.

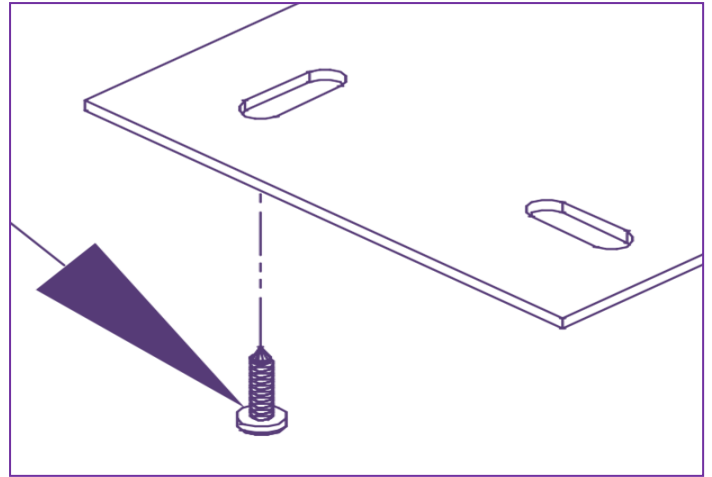

STEP 2: ATTACH THE LEG TO THE TOP PANEL

Fasten the Leg to the bottom opposite side of the Top Panel with the screws in the holes provided.

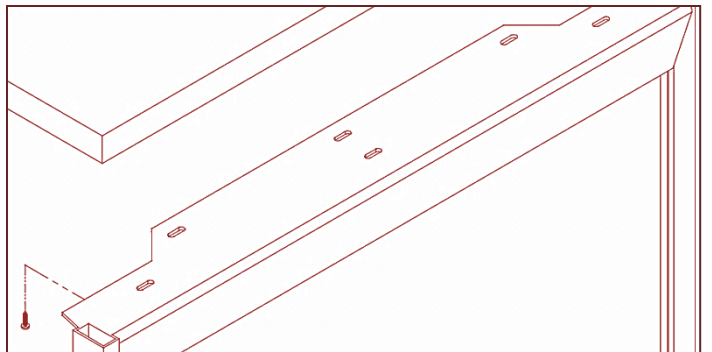
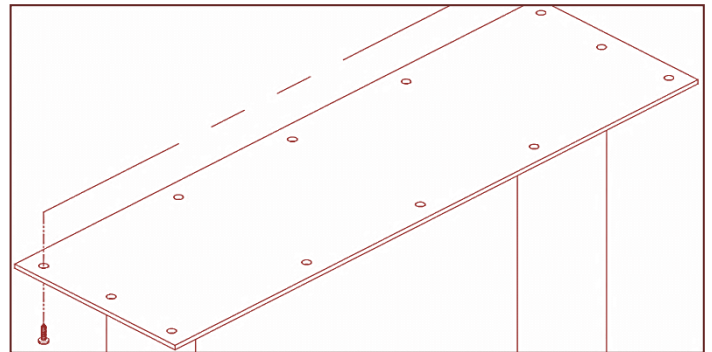

Integrate Assembly Instructions
Conference End 48"
(Part No. I48CEP)

Your Final Assembled Product should look like below (Based on the ordered Configuration)

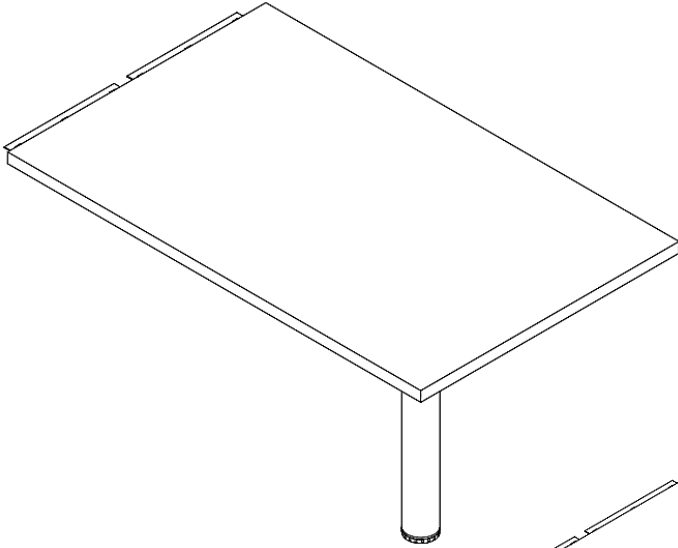

Conference End with 3 Inch Metal Column

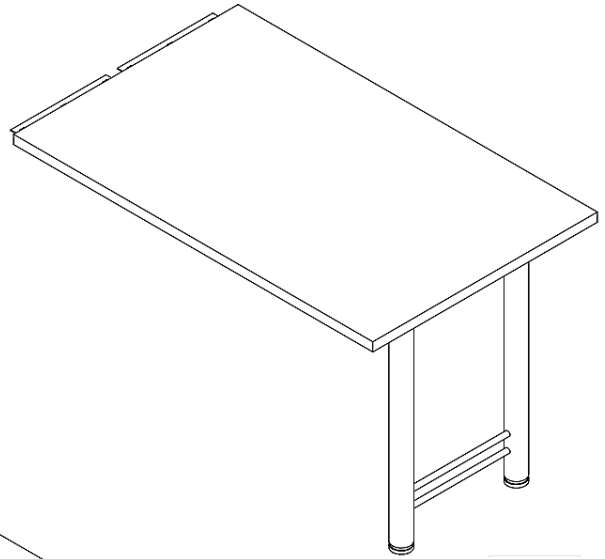

Conference End with H-Leg 450

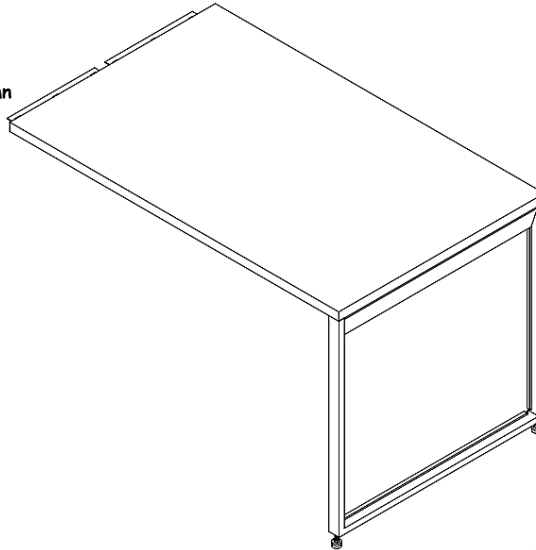

Conference End with Open Panel Leg

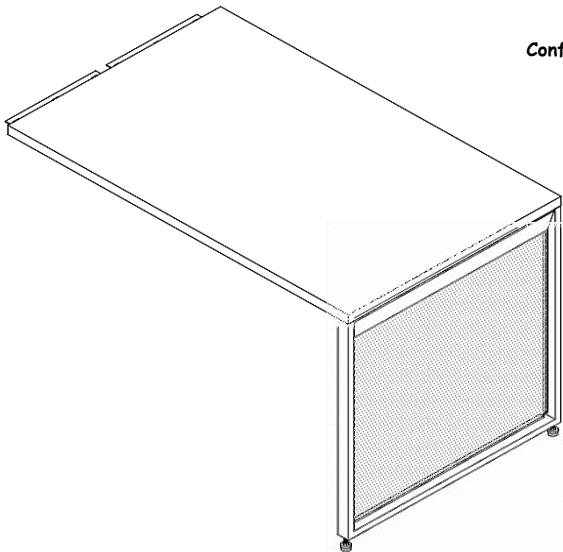

Conference End with One Panel Leg

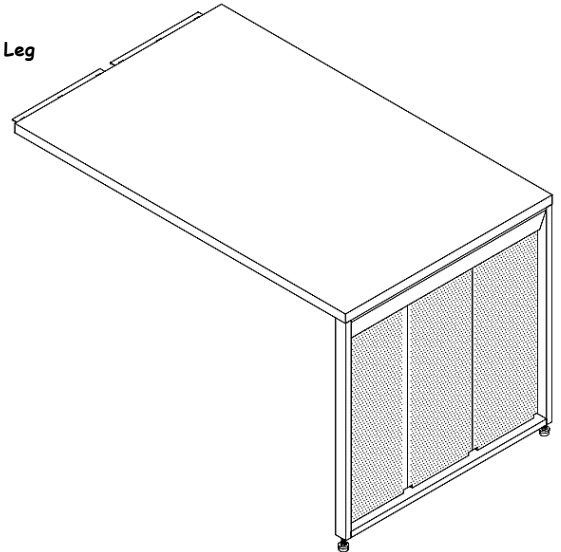

Conference End with Three Panel Leg

Integrate Assembly Instructions
Credenza Base Double Door
(Part No. I36CBCS)

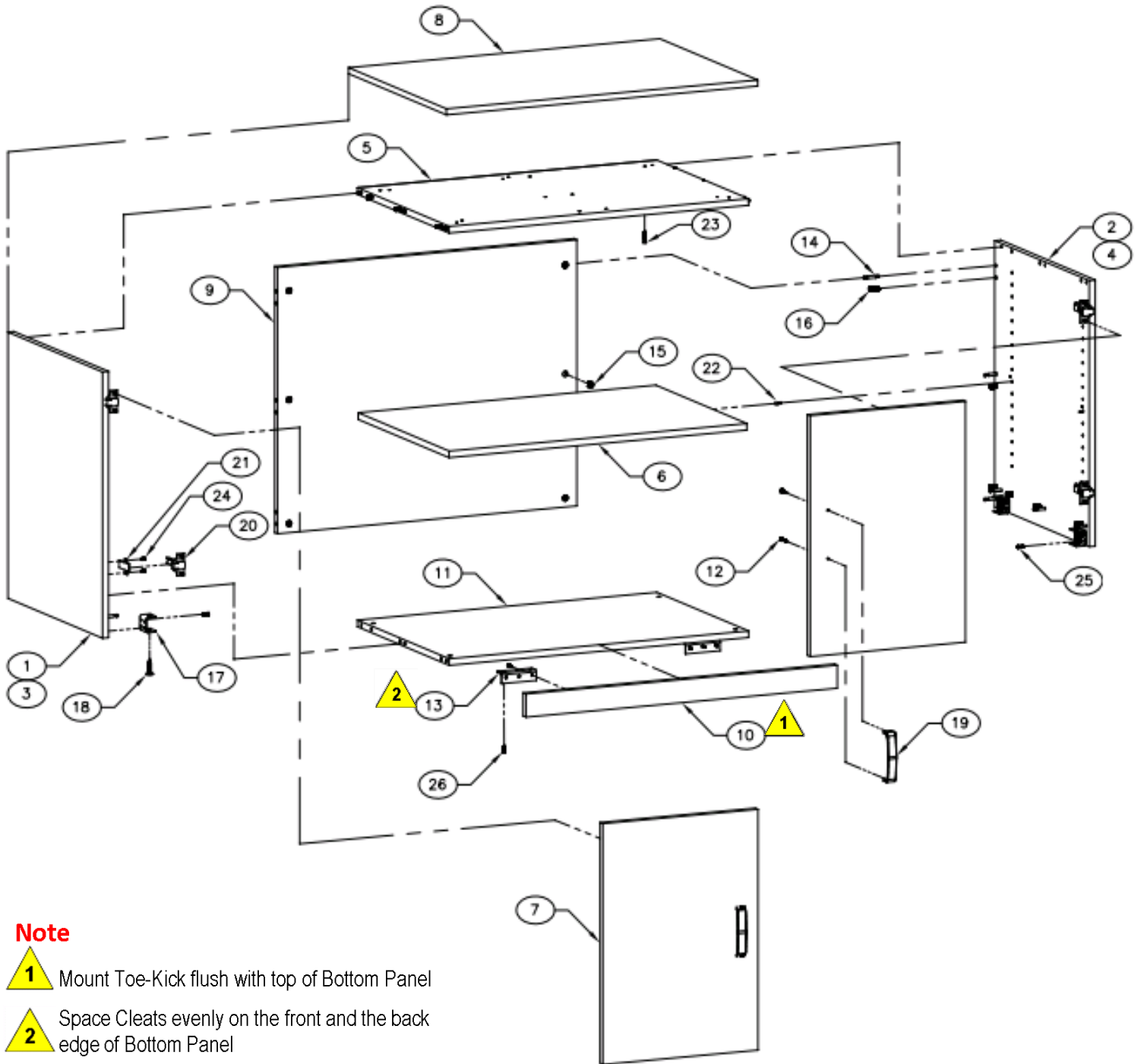

Note

- 1** Mount Toe-Kick flush with top of Bottom Panel
- 2** Space Cleats evenly on the front and the back edge of Bottom Panel

**Integrate Assembly Instructions
Credenza Base Double Door**

(Part No. I36CBCS)

Item #	Part #	Description	Quantity
1 & 3	ISA30121	Left End Panel & Hardware	1
2 & 4	ISA30123	Right End Panel & Hardware	1
5	ISA30125	Interior Top Panel	1
6	ISA30135	Shelf Panel	1
7	ISA30139	Door Panel	2
8	ISA30063	Top Panel	1
9	ISA30067	Back Panel	1
10	ISA30071	Toe Kick Panel	1
11	ISA30075	Bottom Panel	1

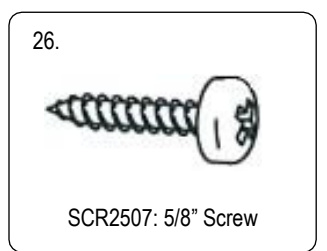
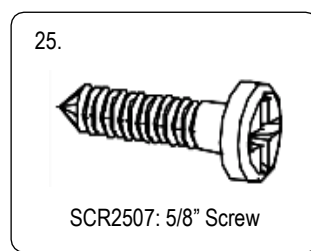
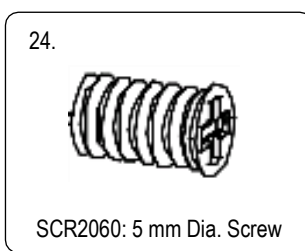
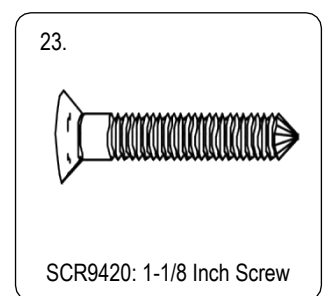
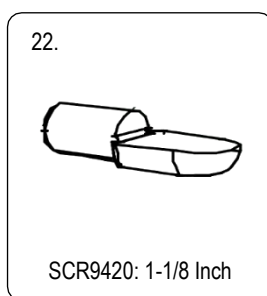
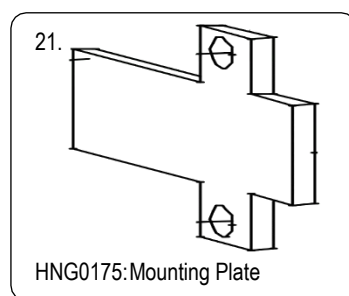
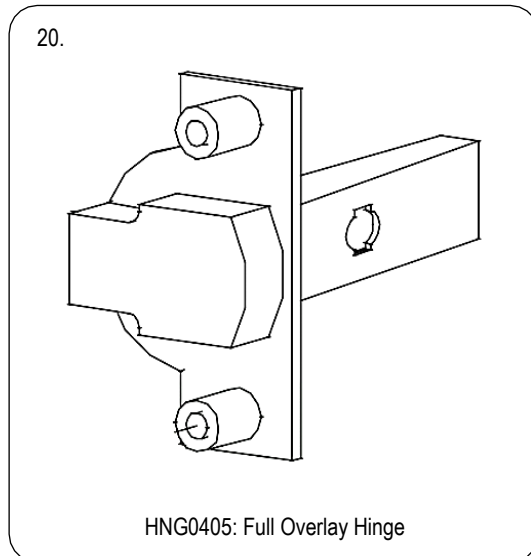
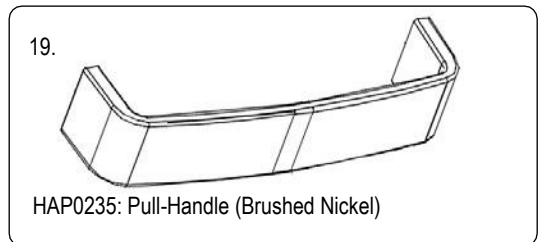
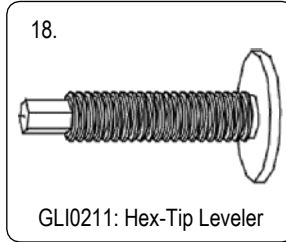
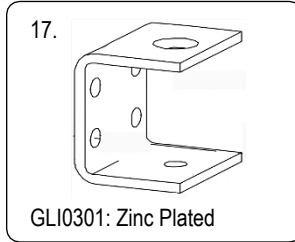
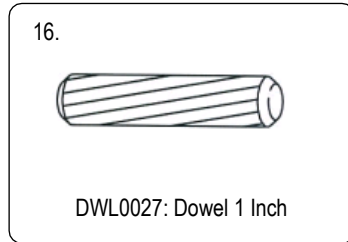
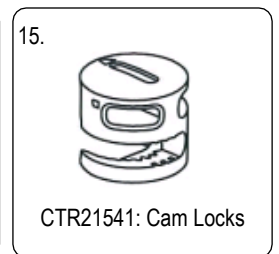
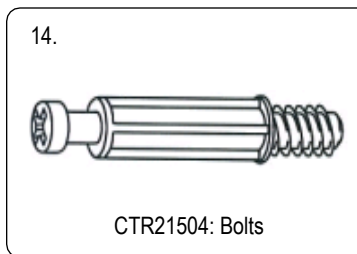
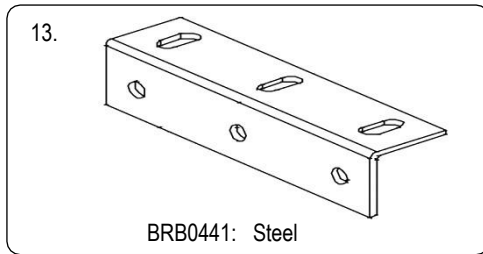
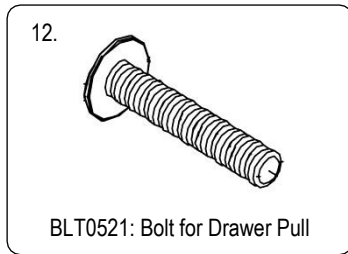

Integrate Assembly Instructions
Credenza Base Double Door
(Part No. I36CBCS)

Your Final Assembled Product should look like below (Based on the Ordered Configuration)

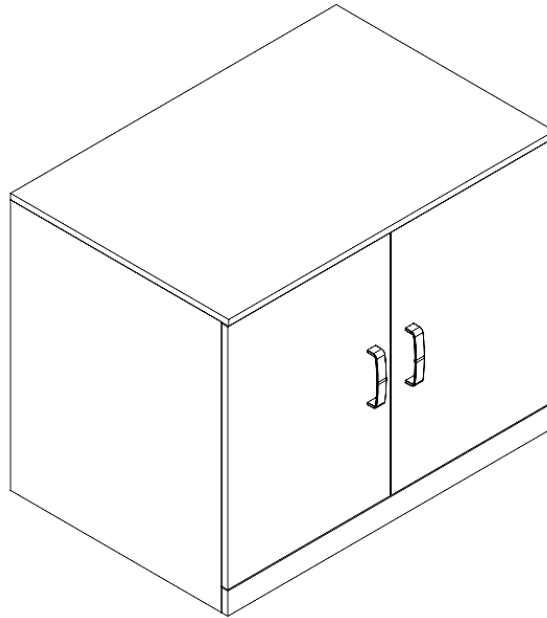

Credenza Double Door Stand-Alone Configuration

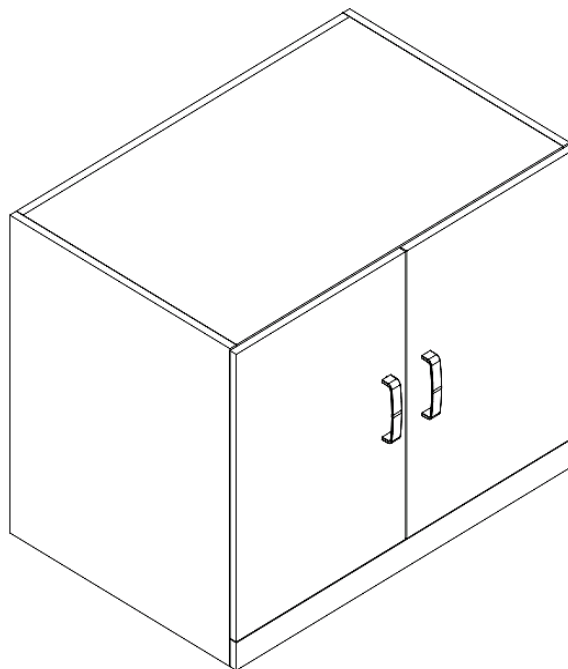

Credenza Double Door WorkSurface Supporting Configuration
For Assistance Call:
(800) 827-3168
Mon-Fri 6:00 a.m.-3:30 p.m. EST

**Integrate Assembly Instructions
Credenza Base Single Door**

(Part No. I16CBCS)

Note

- 1** Mount Toe-Kick flush with top of Bottom Panel
- 2** Space Cleats evenly on the front and the back edge of Bottom Panel

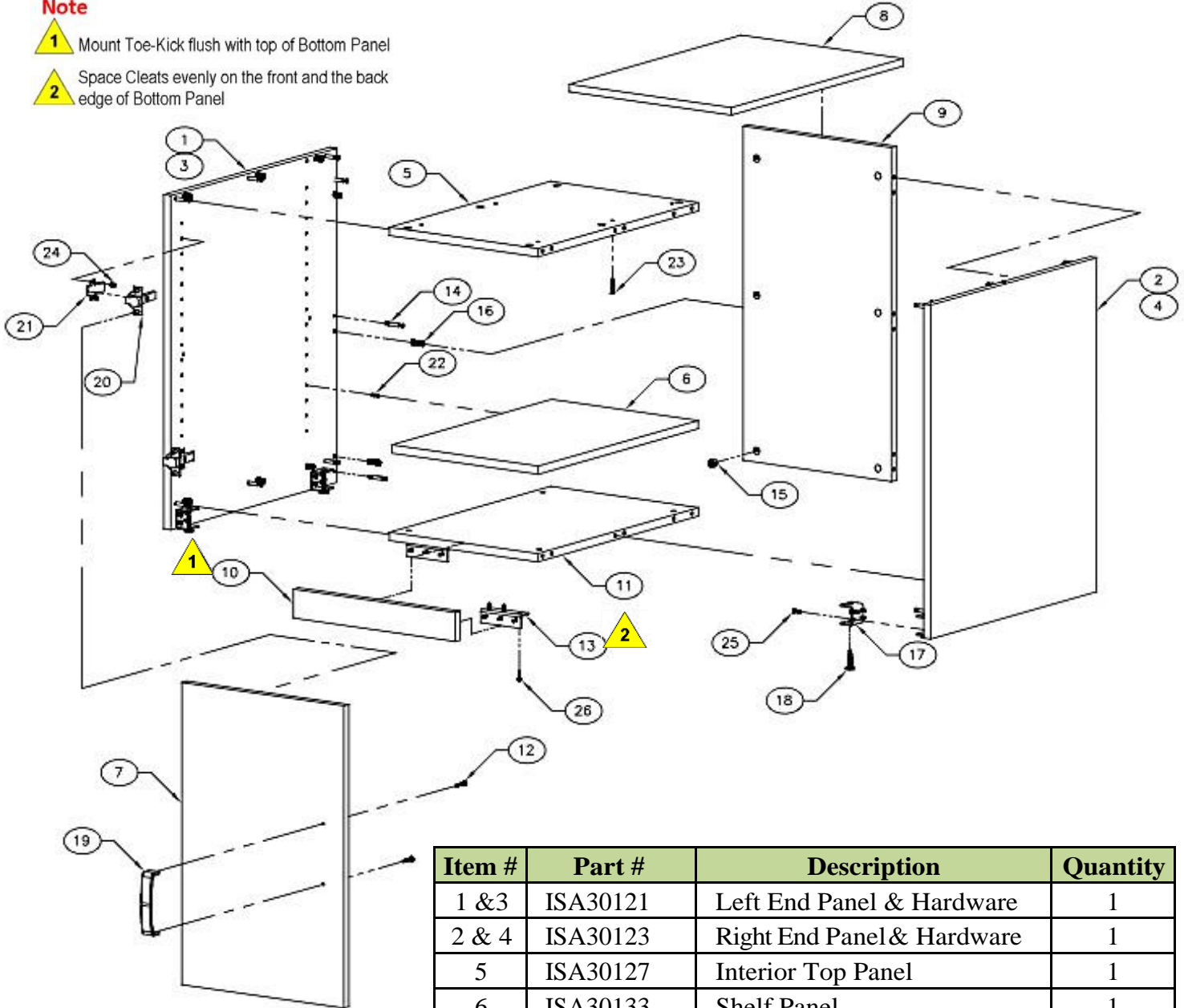

Item #	Part #	Description	Quantity
1 & 3	ISA30121	Left End Panel & Hardware	1
2 & 4	ISA30123	Right End Panel & Hardware	1
5	ISA30127	Interior Top Panel	1
6	ISA30133	Shelf Panel	1
7	ISA30137	Door Panel	1
8	ISA30061	Top Panel	1
9	ISA30065	Back Panel	1
10	ISA30069	Toe Kick Panel	1
11	ISA30073	Bottom Panel	1

Integrate Assembly Instructions
Credenza Base Single Door
(Part No. I16CBCS)



BLT0521: Bolt for Drawer Pull

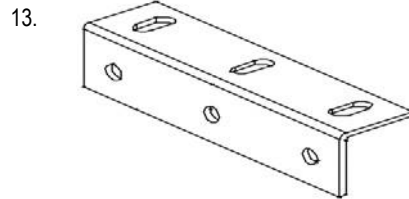

BRB0441: Steel Cleats

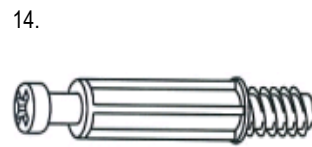

CTR21504: Bolts

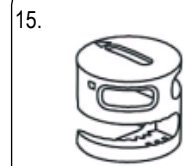

CTR21541: Cam Locks



DWL0027: Dowel 1 Inch

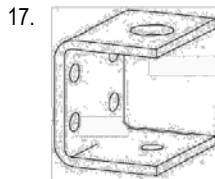

GLI0301: Zinc Plated

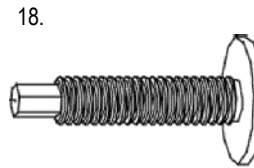

GLI0211: Hex-Tip Leveler

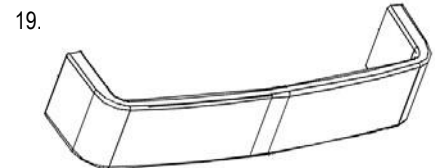

HAP0235: Pull-Handle (Brushed Nickel)

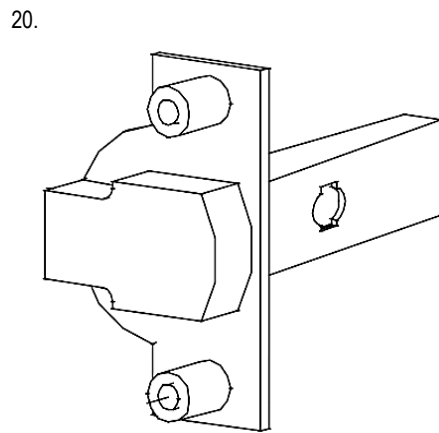

HNG0405: Full Overlay Hinge

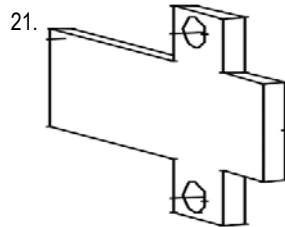

HNG0175: Mounting Plate

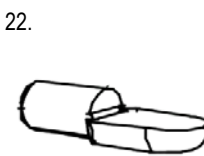

PIN4000: Shelf Pin

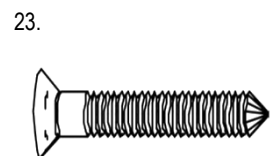

SCR0677: 1-1/8 Inch Screw

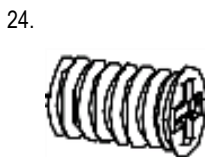

SCR2060: 5 mm Dia Screw

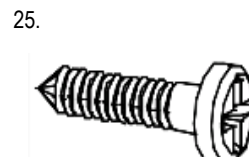

SCR2507: 5/8" Screw

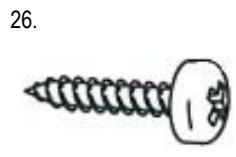

SCR2507: 5/8" Screw

Your Final Assembled Product should look like below (Based on the Ordered Configuration)

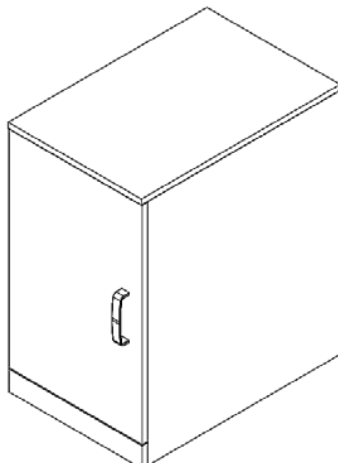

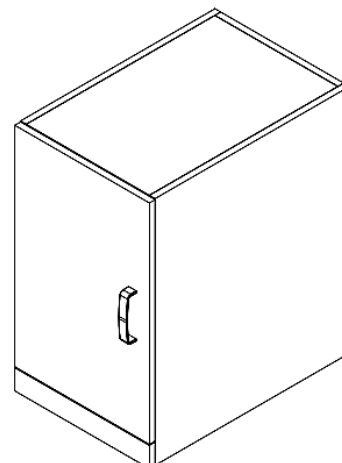

Credenza Single Door Stand-Alone Configuration







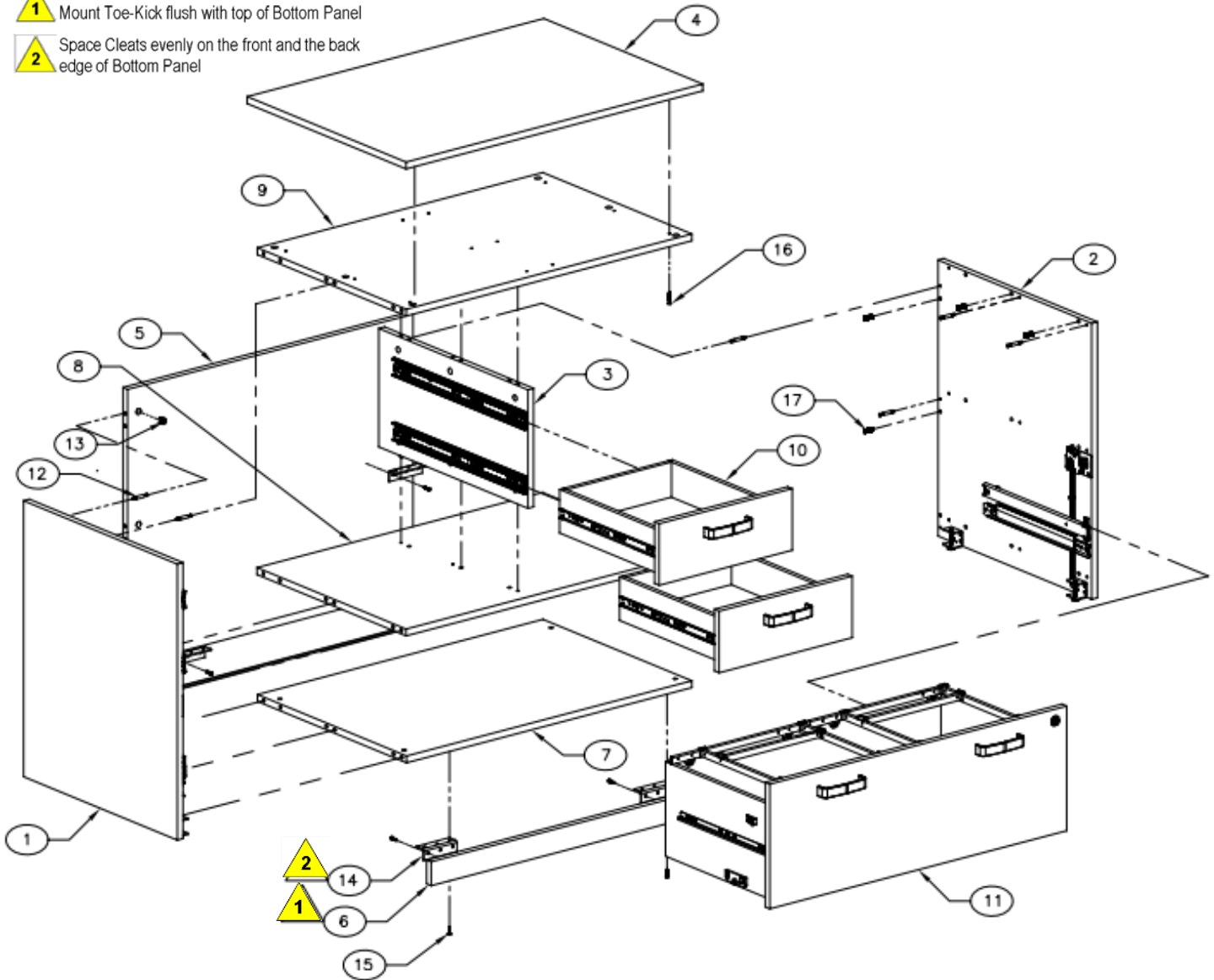

Credenza Single Door WorkSurface Supporting Configuration

Note

-  1 Mount Toe-Kick flush with top of Bottom Panel
-  2 Space Cleats evenly on the front and the back edge of Bottom Panel

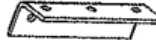

Item #	Part #	Description	Quantity
1	ISA30029	Left End Panel Assembly	1
2	ISA30033	Right End Panel Assembly	1
3	ISA30037	Divider Panel	1
4	ISA30063	Top Panel	1
5	ISA30067	Back Panel	1
6	ISA30071	Toe Kick Panel	1
7	ISA30075	Bottom Panel	1
8	ISA30077	Middle Panel	1
9	ISA30081	Top Interior Panel	1
10	ISA130011	Credenza Drawer Assembly	2
11	ISA130029	Lateral File Drawer Assembly	1

Item #	Part #	Description	Quantity
12	CTR21504	Bolts 	30
13	CTR21541	Cam Locks 	30
14	BRB04411	Steel Cleats 	5
15	SCR2507	5/8 Inch Philips Screw 	30
16	SCR0677	Screw 1-1/4 Inch 	12
17	DWL0027	Dowel 1 Inch 	30

Integrate Assembly Instructions
Credenza Base Mixed Drawer

(Part No. I36CBM)

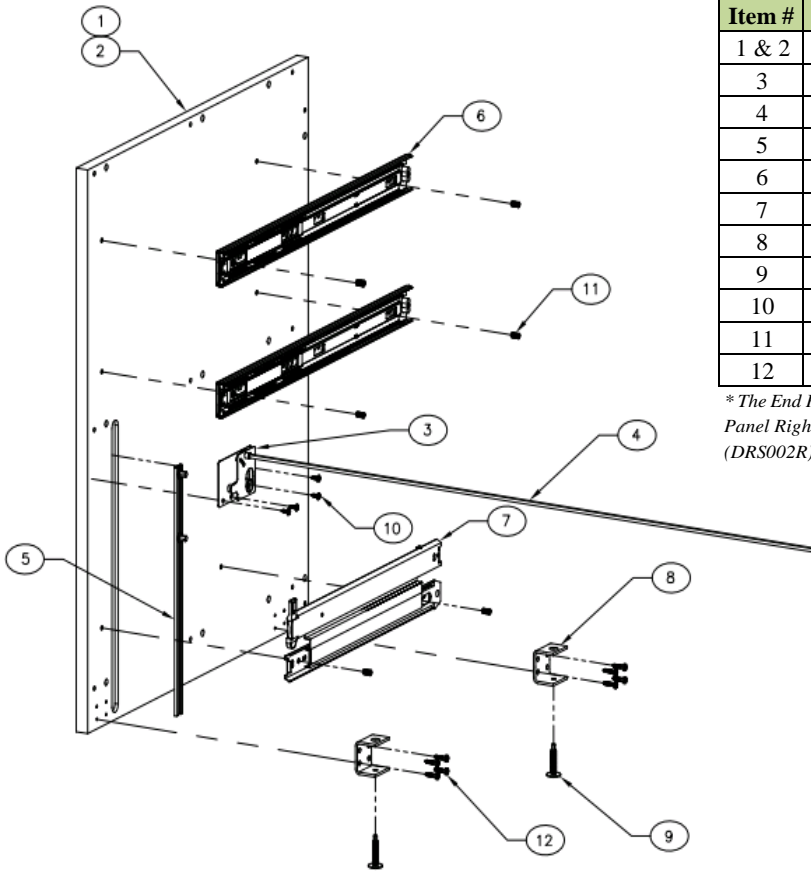

Item #	Part #	Description	Quantity
1 & 2	ISA50055	End Panel Left*	1
3	LOX0121	Remote Actuator	1
4	LOX0119	Shaft 36"	1
5	LOX0123	Central Lock	1
6	DRS0006	20" Drawer Slide for Box Drawers	2
7	DRS0002L	16" Drawer Slide (L) for Lateral File	1
8	GLI0301	Zinc Plated Gusset	2
9	GLI0211	Hex Tip Leveler	2
10	SCR9404	7/16 Sheet metal Screw	4
11	SCR2060	Screw 5mm Dia.	6
12	SCR2507	5/8 Screw	8

*The End Panel Right (ISA30033) drawing excludes 36" Shaft (Item 4) and replaces End Panel Right (ISA30057) in item 1, Drive Actuator (LOX0114) in Item 3 and Right Glide (DRS002R) in Item 6

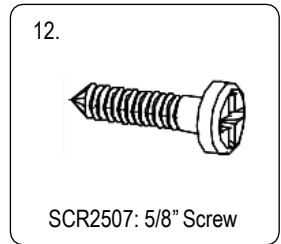
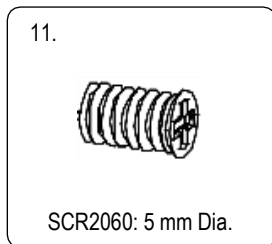
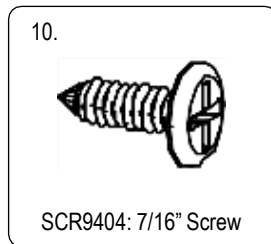
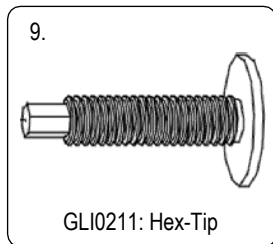
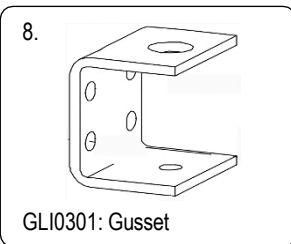
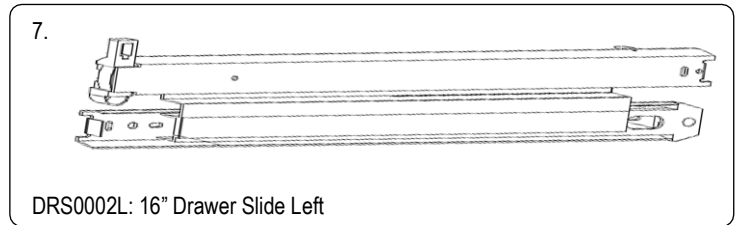
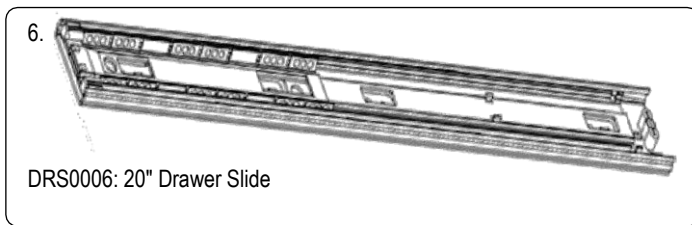
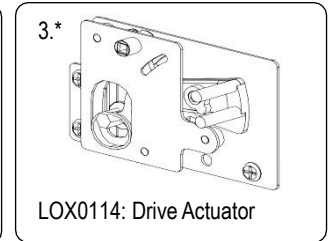
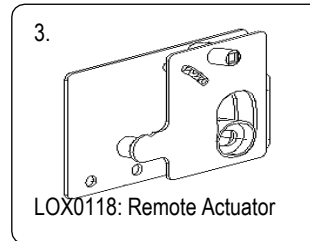

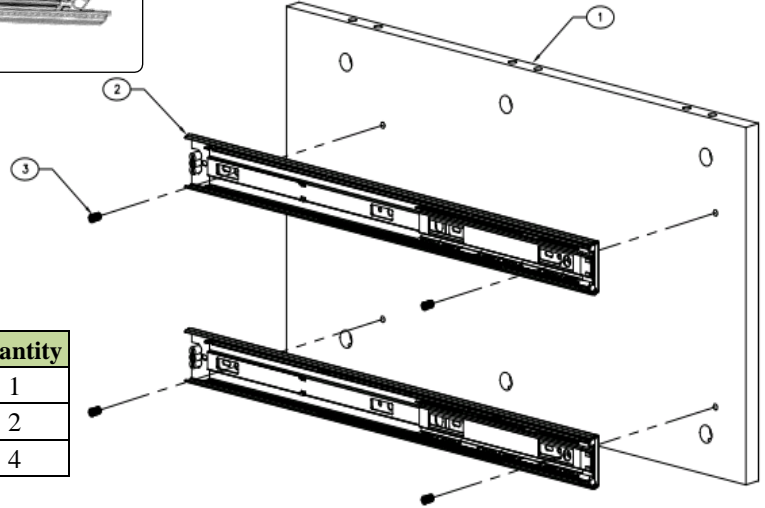
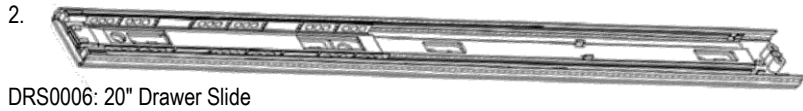

ISA30037: Divider Panel Subassembly

Item #	Part #	Description	Quantity
1	ISA50059	Divider Panel	1
2	DRS0006	20" Drawer Slide for Box Drawers	2
3	SCR2060	Screw 5mm Dia.	4

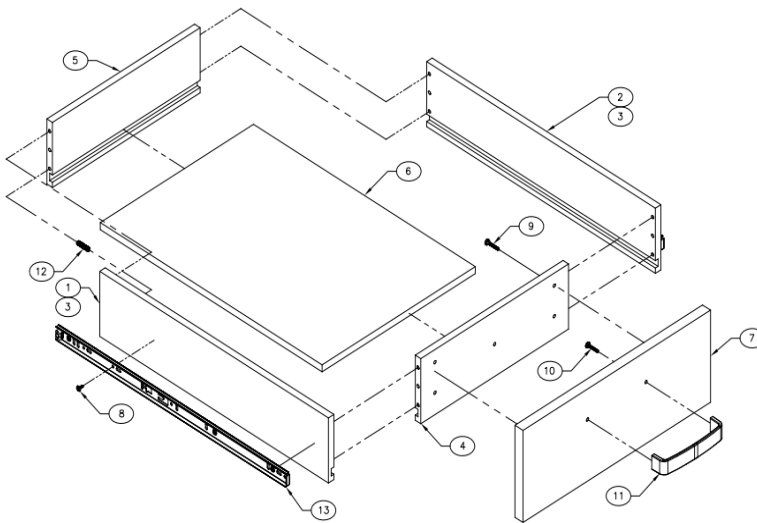

ISA130011: Credenza Box Drawer

Item #	Part #	Description	Quantity
1	ISA130055	Hardware Location Left	1
2	ISA130057	Hardware Location Right	1
3	ISA130079	Credenza Box Drawer Side	2
4	ISA130089	Credenza Box Drawer Front	1
5	ISA130099	Credenza Box Drawer Back	1
6	ISA1300105	Credenza Box Drawer Bottom	1
7	ISA1300113	Credenza Box Drawer Face	1

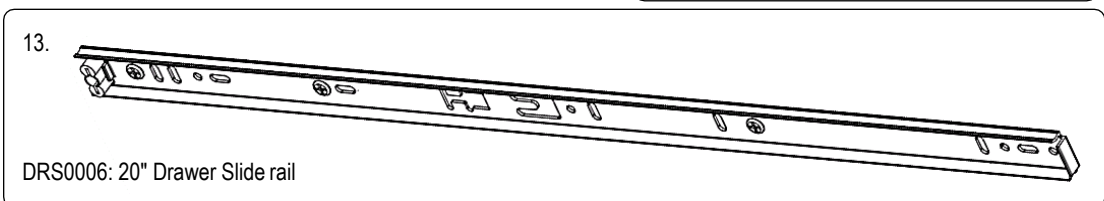
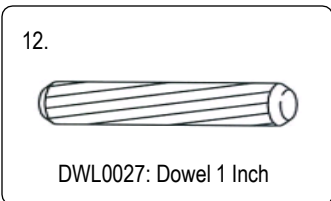
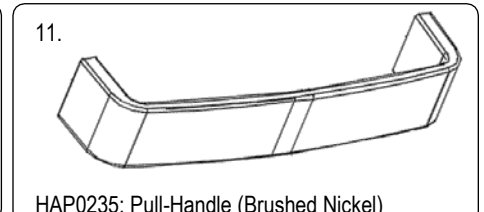
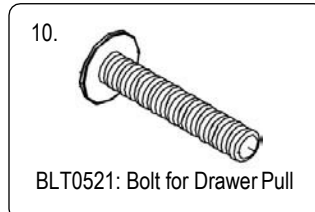
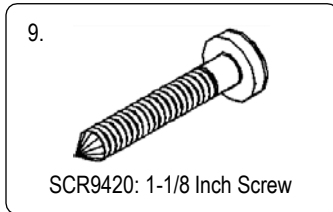

Integrate Assembly Instructions
Credenza Base Mixed Drawer

(Part No. I36CBM)

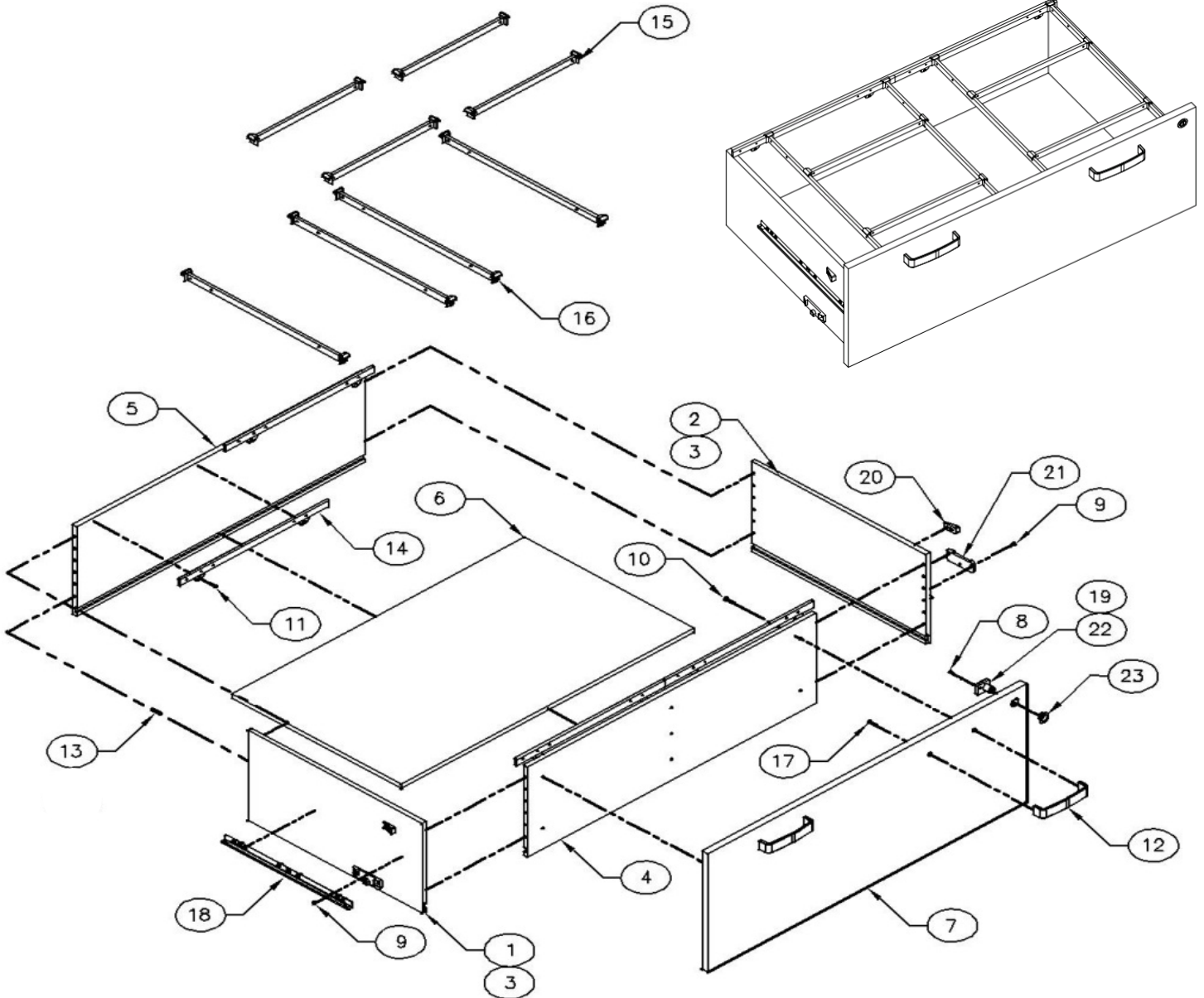

Item #	Part #	Description	Quantity
1	ISA130071	Hardware Location Left	1
2	ISA130073	Hardware Location Right	1
3	ISA130083	Lateral File Drawer Side	2
4	ISA130093	Lateral File Drawer Front	1
5	ISA1300103	Lateral File Drawer Back	1
6	ISA1300107	Lateral File Drawer Bottom	1
7	ISA1300121	Lateral File Drawer Face w/lock	1

Cont...

8.



SCR2507: 5/8 Inch Screw

9.



SCR9404: 7/16" Screw

10.

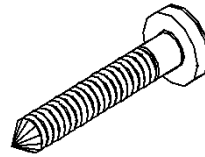

SCR9420: 1-1/8 Inch Screw

11.

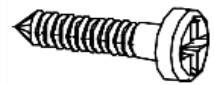

SCR2507: 5/8" Screw

12.

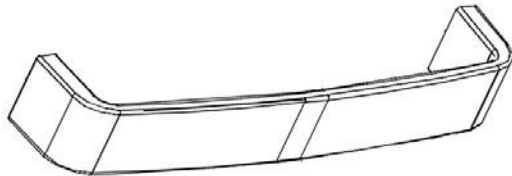

HAP0235: Pull-Handle (Brushed Nickel)

13.



DWL0027: Dowel 1 Inch

17.



BLT0521: Bolt for Drawer Pull

14.

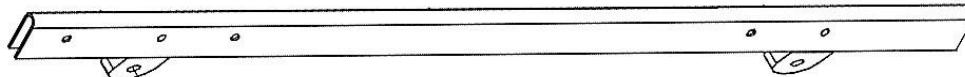

FFUNB1681B: File Frame (Side to Side)

15.

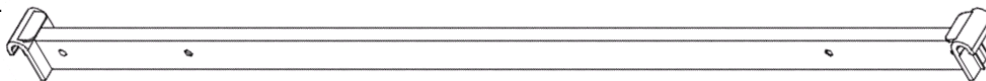

FFLETB: File Frame (Cross Rail)

16.

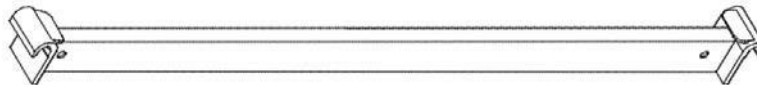

FFIC21525: File Frame (Cross Rail)

18.

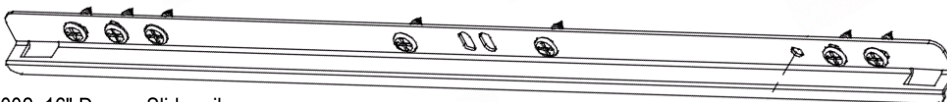

DRS0002: 16" Drawer Slide rail

19.

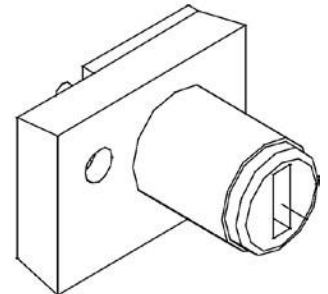

LOX0113: Lock Cylinder Body

20.

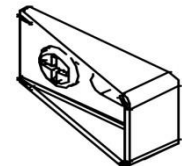

LOX0117: Drawer Locking Clip

21.

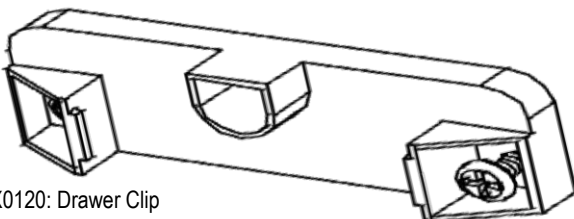

LOX0120: Drawer Clip

22.

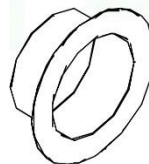

LOX0150: Lock-Bezel

Integrate Assembly Instructions
Credenza Base Mixed Drawer
(Part No. I36CBM)

Your Final Assembled Product should look like below (Based on the Ordered Configuration)

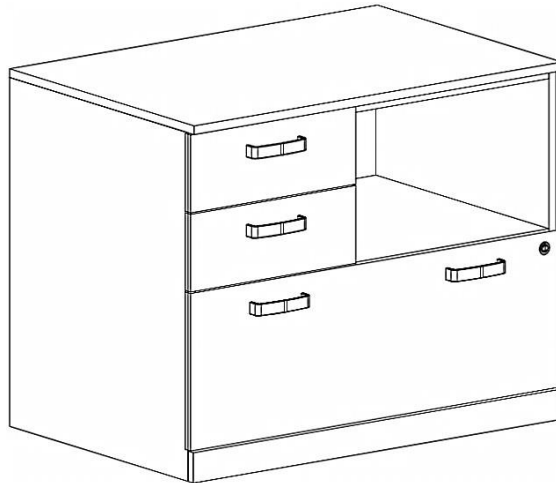

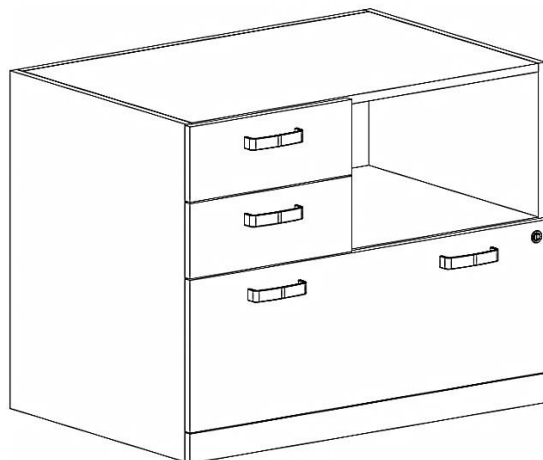

Credenza Base Mixed Drawer Box-Box
Left Stand-Alone Configuration



Credenza Base Mixed Drawer Box-Box Left
WorkSurface Supporting Configuration





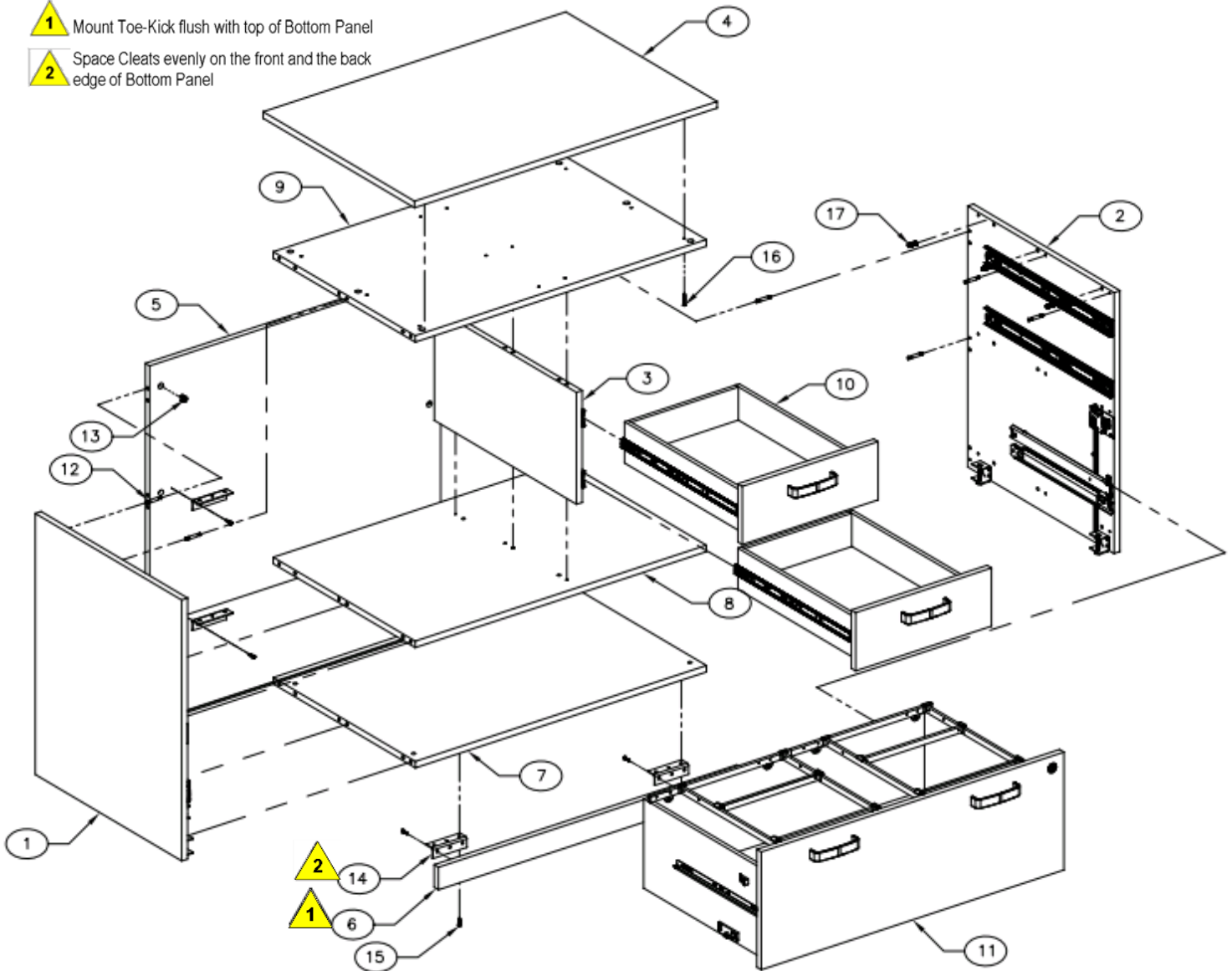

Integrate Assembly Instructions
Credenza Base Mixed Drawer
(Part No. I36CBM)

Note

-  1 Mount Toe-Kick flush with top of Bottom Panel
-  2 Space Cleats evenly on the front and the back edge of Bottom Panel

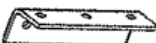

Item #	Part #	Description	Quantity
1	ISA30017	Left End Panel	1
2	ISA30021	Right End Panel	1
3	ISA30025	Divider Panel	1
4	ISA30063	Top Panel	1
5	ISA30067	Back Panel	1
6	ISA30071	Toe Kick Panel	1
7	ISA30075	Bottom Panel	1
8	ISA30077	Middle Panel	1
9	ISA30081	Top Interior Panel	1
10	ISA130011	Credenza Drawer Assembly	2
11	ISA130029	Lateral File Drawer Assembly	1

Item #	Part #	Description	Quantity
12	CTR21504	Bolts 	30
13	CTR21541	Cam Locks 	30
14	BRB0441	Steel Cleats 	5
15	SCR2507	5/8 Inch Philips Screw 	30
16	SCR0677	Screw 1-1/4 Inch 	12
17	DWL0027	Dowel 1 Inch 	30

Integrate Assembly Instructions
Credenza Base Mixed Drawer

(Part No. I36CBM)

Item #	Part #	Description	Quantity
1 & 2	ISA50049	End Panel Left*	1
3	LOX0121	Remote Actuator	1
4	LOX0119	Shaft 36"	1
5	LOX0123	Central Lock	1
6	DRS0002L	16" Drawer Slide (L) for Lateral File	1
7	GLI0301	Zinc Plated Gusset	2
8	GLI0211	Hex Tip Lvlr	2
9	SCR9404	7/16 Sheetmetal Screw	4
10	SCR2060	Screw 5mm Dia.	6
11	SCR2507	5/8 Screw	8

* The End Panel Right (ISA30021) drawing excludes 36" Shaft (Item 4); Includes 20" Slides (DRS0006); and replaces End Panel Right (ISA30051) in Item 1, Drive Actuator (LOX0114) in Item 3, and Right Glide (DRS0002R) in Item 6

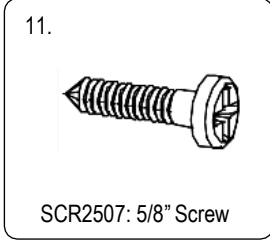
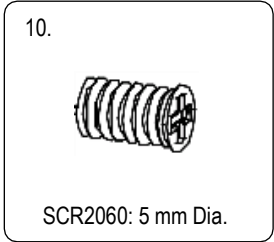
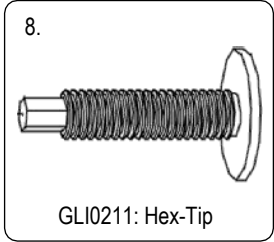
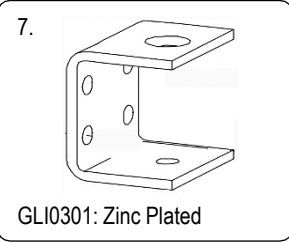
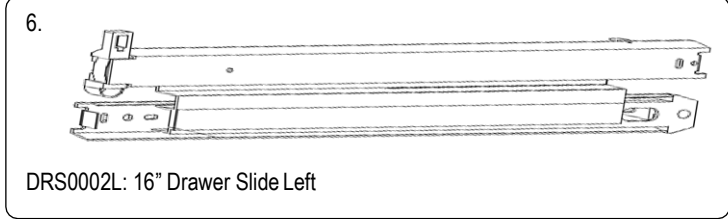
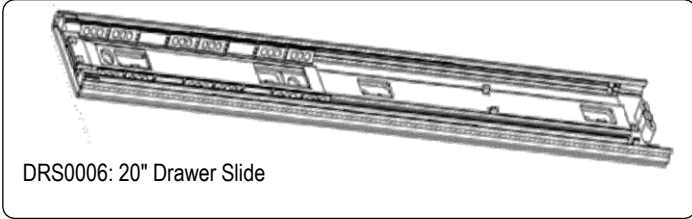
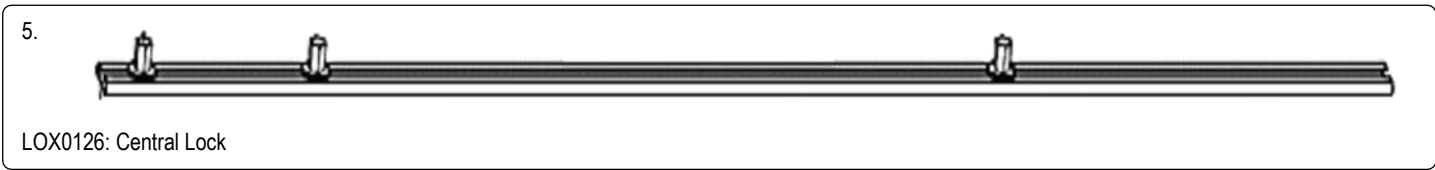
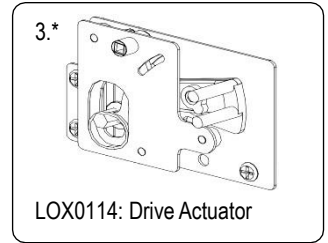
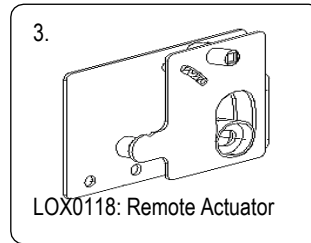
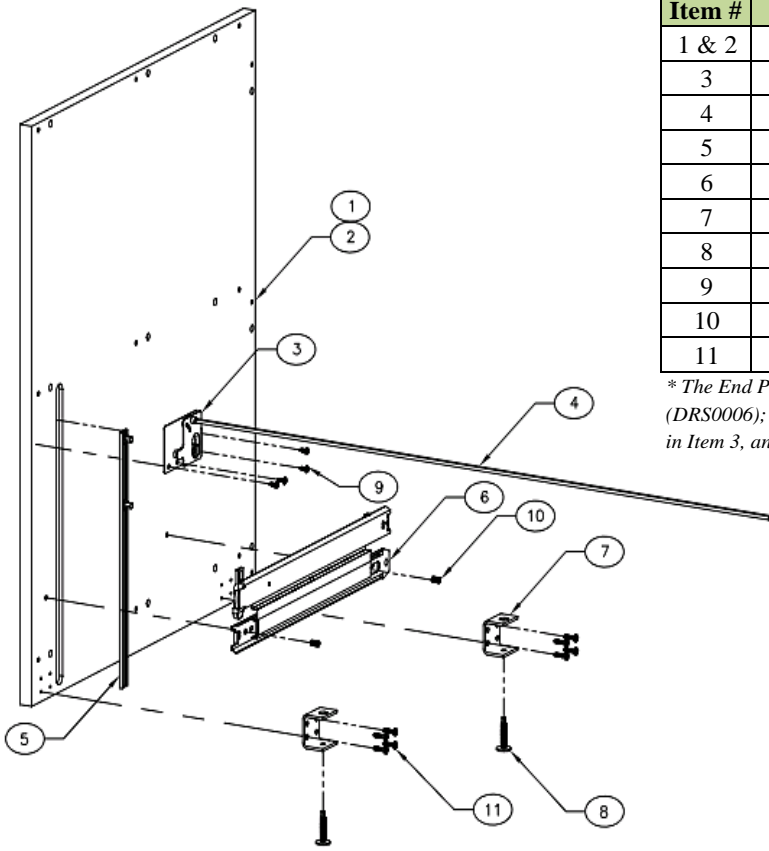

Integrate Assembly Instructions
Credenza Base Mixed Drawer

(Part No. I36CBM)

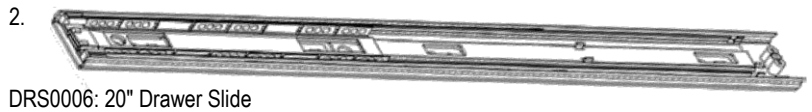
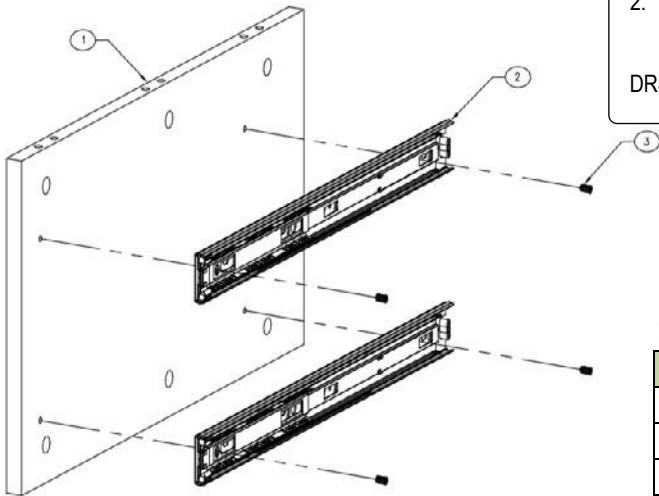

ISA30025: Divider Panel Subassembly

Item #	Part #	Description	Quantity
1	ISA50053	Divider Panel	1
2	DRS0006	20" Drawer Slide for Box Drawers	2
3	SCR2060	Screw 5mm Dia.	4

ISA130011: Credenza Box Drawer

Item #	Part #	Description	Quantity
1	ISA130055	Hardware Location Left	1
2	ISA130057	Hardware Location Right	1
3	ISA130079	Credenza Box Drawer Side	2
4	ISA130089	Credenza Box Drawer Front	1
5	ISA130099	Credenza Box Drawer Back	1
6	ISA1300105	Credenza Box Drawer Bottom	1
7	ISA1300113	Credenza Box Drawer Face	1

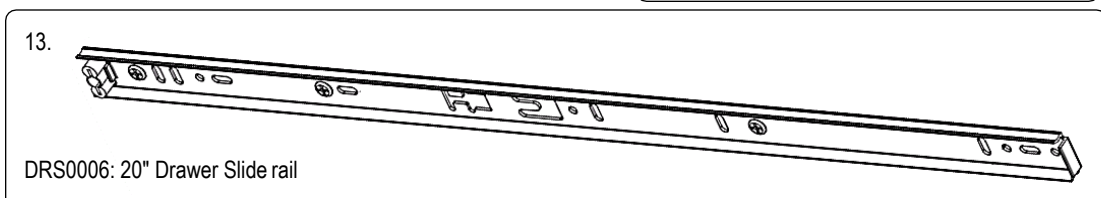
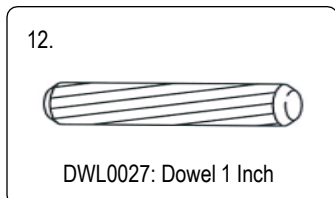
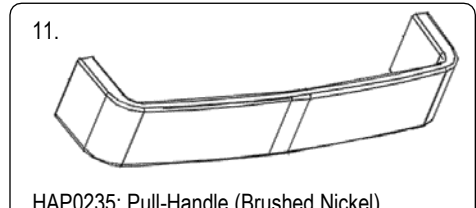
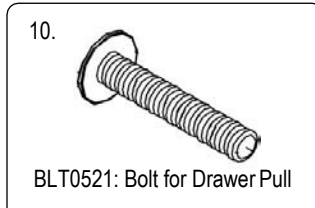
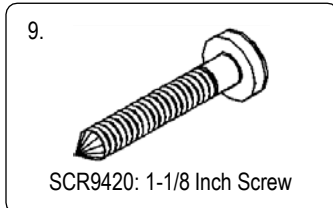
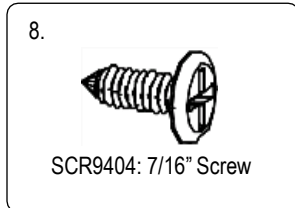
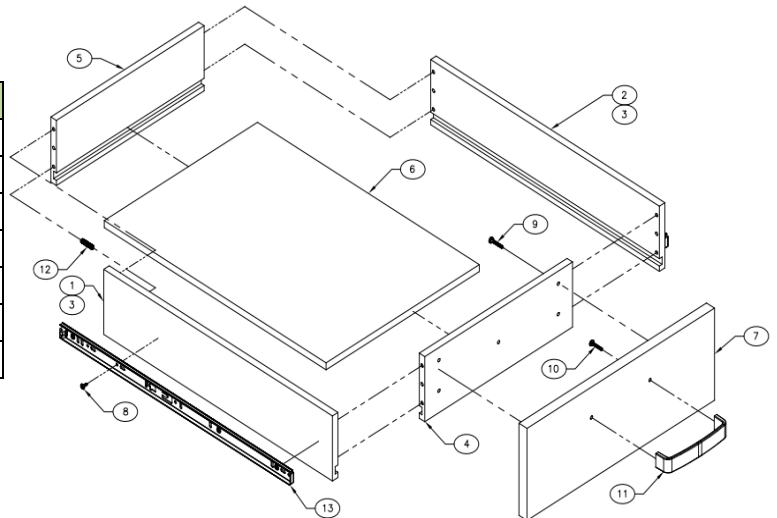

Integrate Assembly Instructions
Credenza Base Mixed Drawer

(Part No. I36CBM)

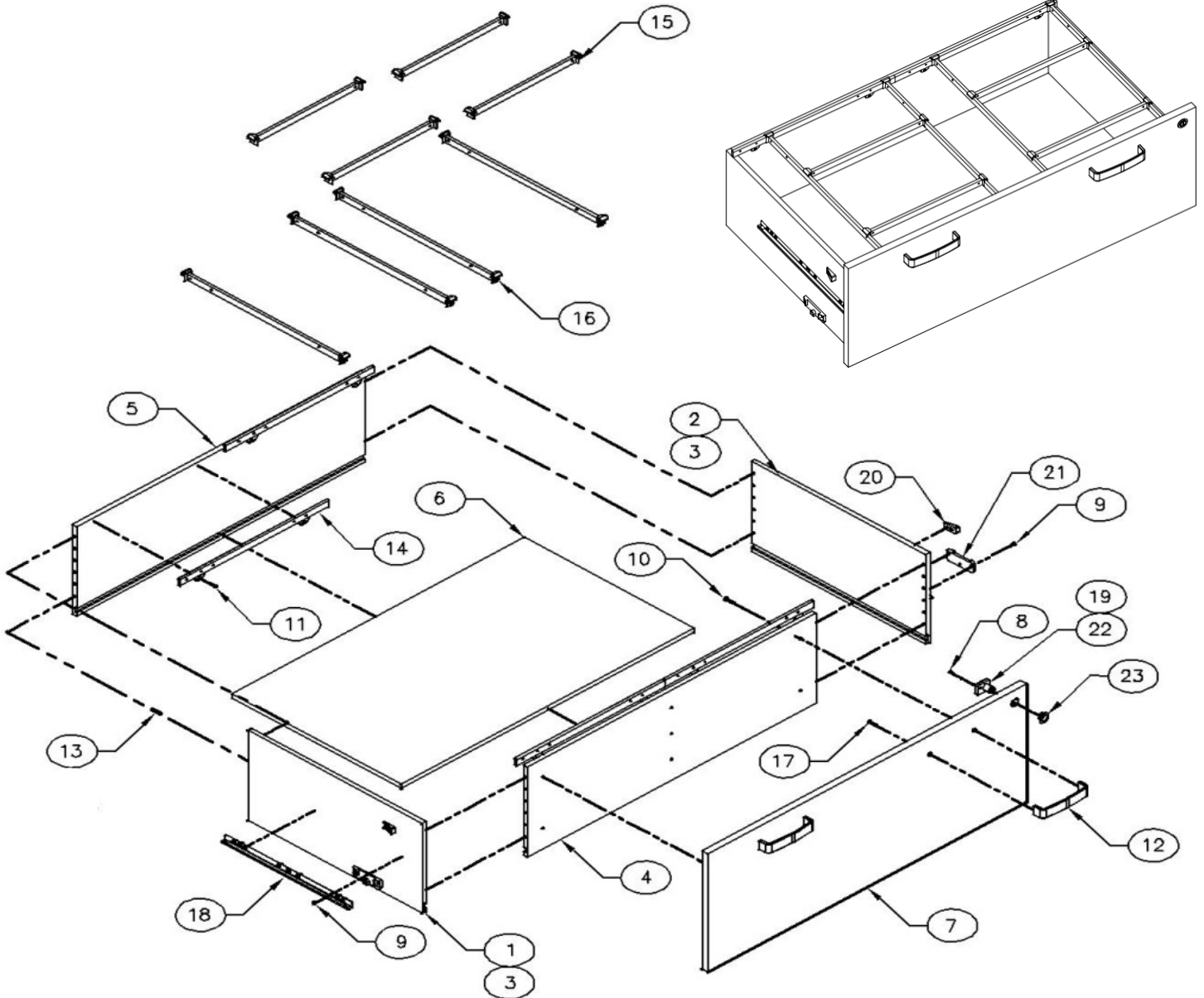

Item #	Part #	Description	Quantity
1	ISA130071	Hardware Location Left	1
2	ISA130073	Hardware Location Right	1
3	ISA130083	Lateral File Drawer Side	2
4	ISA130093	Lateral File Drawer Front	1
5	ISA1300103	Lateral File Drawer Back	1
6	ISA1300107	Lateral File Drawer Bottom	1
7	ISA1300121	Lateral File Drawer Face w/lock	1

Cont...

8.



SCR2507: 5/8 Inch Screw

9.



SCR9404: 7/16" Screw

10.

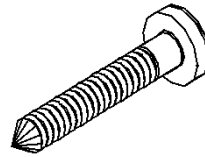

SCR9420: 1-1/8 Inch Screw

11.

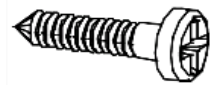

SCR2507: 5/8" Screw

12.

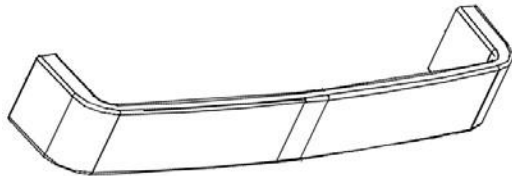

HAP0235: Pull-Handle (Brushed Nickel)

13.



DWL0027: Dowel 1 Inch

17.



BLT0521: Bolt for Drawer Pull

14.

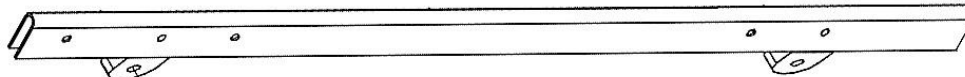

FFUNB1681B: File Frame (Side to Side)

15.

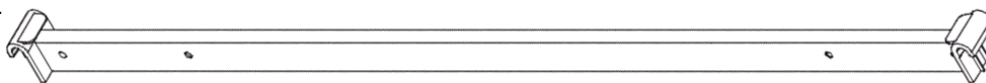

FFLETB: File Frame (Cross Rail)

16.

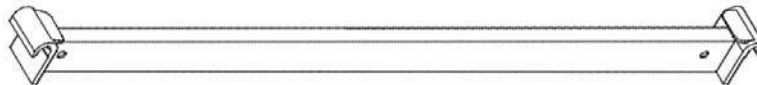

FFIC21525: File Frame (Cross Rail)

18.

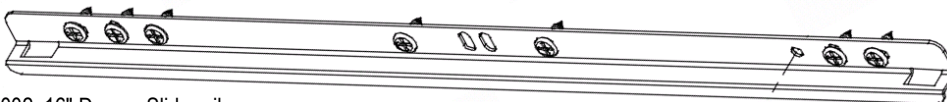

DRS0002: 16" Drawer Slide rail

19.

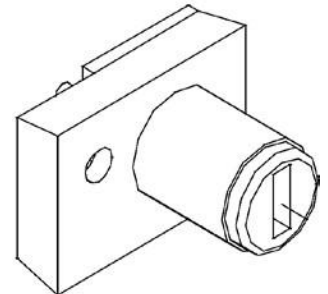

LOX0113: Lock Cylinder Body

20.

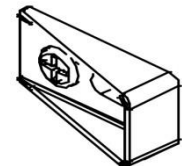

LOX0117: Drawer Locking Clip

21.

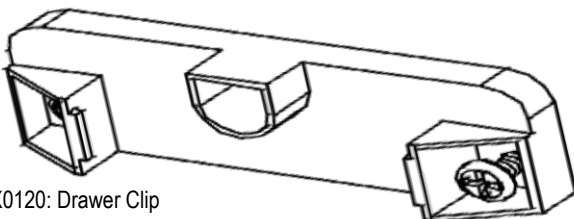

LOX0120: Drawer Clip

22.

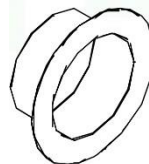

LOX0150: Lock-Bezel

Integrate Assembly Instructions
Credenza Base Mixed Drawer
(Part No. I36CBM)

Your Final Assembled Product should look like below (Based on the Ordered Configuration)

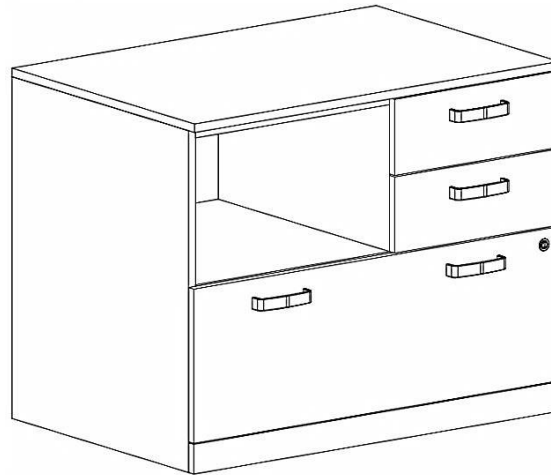



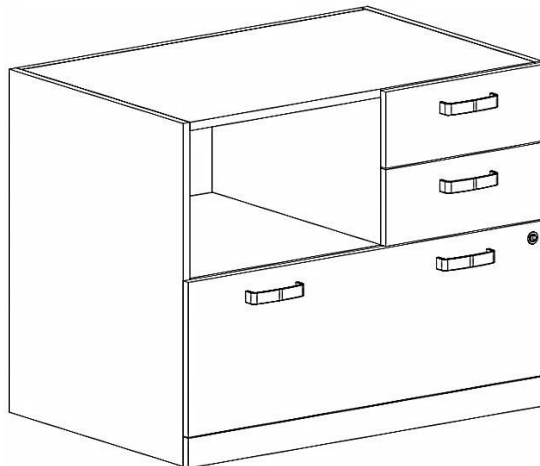



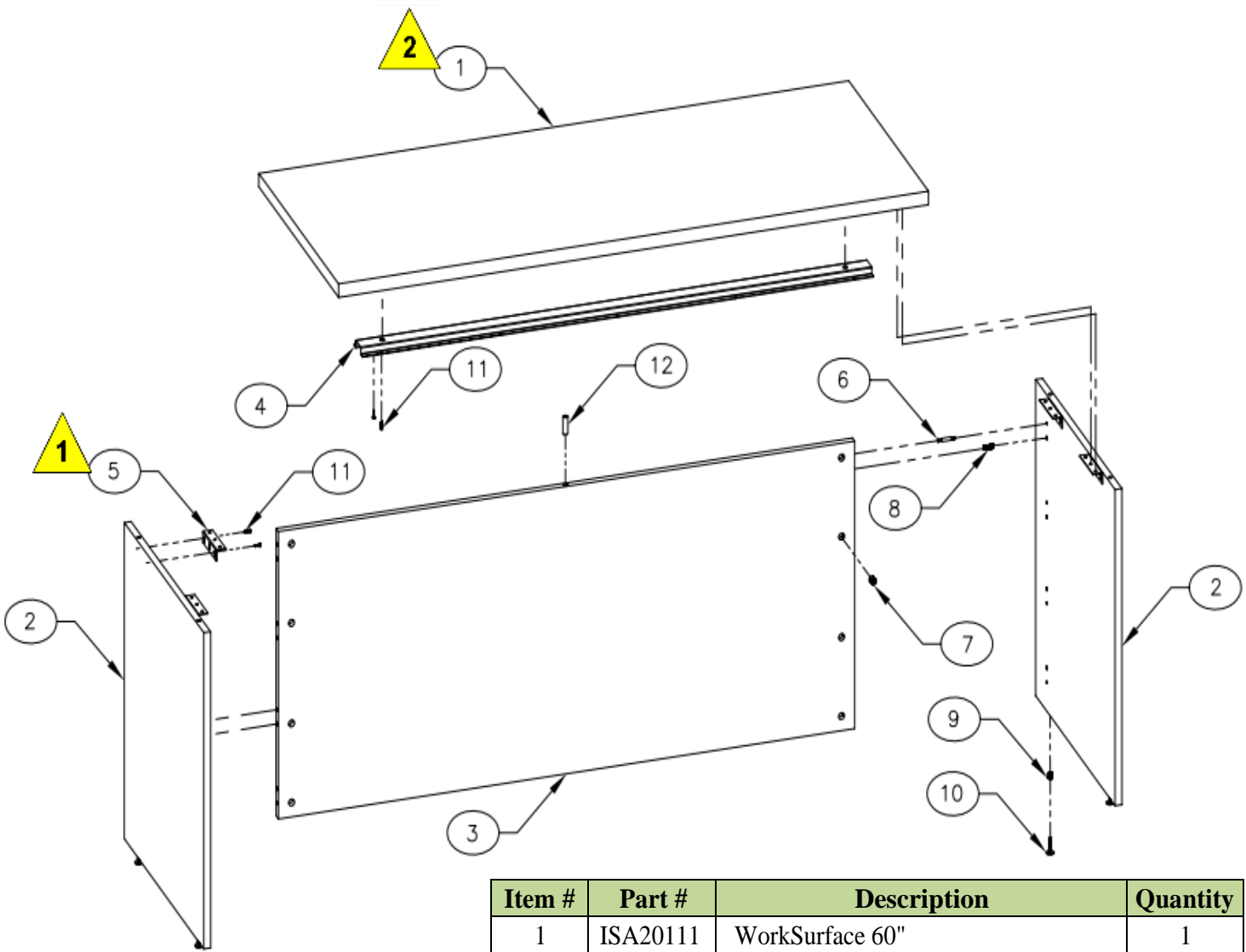

Credenza Base Mixed Drawer Box-Box Right
Stand-Alone Configuration

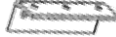



Credenza Base Mixed Drawer Box-Box Right
WorkSurface Supporting Configuration

Integrate Assembly Instructions
Shell Credenza (60" x 24")
(Part No. I60CRSH)





Item #	Part #	Description	Quantity
1	ISA20111	WorkSurface 60"	1
2	ISA20015	End Panel Left/Right	2
3	ISA20019	Modesty Panel 60"	1
4	BKT1657	Stiffner Bracket for WorkSurface	1
5	BRB04411	Steel Cleats 	4
6	CTR21504	Bolts 	8
7	CTR21541	Cam Locks 	8
8	DWL0027	Dowel 1 Inch 	8
9	GLI0191	Insert Nuts for Glides 	4
10	GLI0212	Hex-Base Glides 	4
11	SCR2507	Screw 5/8 Inch 	24
12	SPC4898	Spacer 	1

Warnings

-  Do not over-tighten the screws.
-  Do not turn cam-locks more than 180°.

Note

-  Space Cleats Evenly at top edge of inside face of panel
-  Locate Top flush with back and outer edges of End panels. Leave excess overhang to the front.
- Assembly should be performed on a clean flat floor.
- Verify all items are received before assembling.

Tools

- #2 Phillips Screwdriver
- 5mm wrench

STEP 1: ATTACH CLEATS TO THE END PANELS

Place the Left and Right End Panels (Item 2) on a flat surface. Space the 2 Steel Cleats (item 5) evenly on the top edge of inside face of each panel and fasten with the Screws (Item 11) to the End panels. (See Fig. 1)

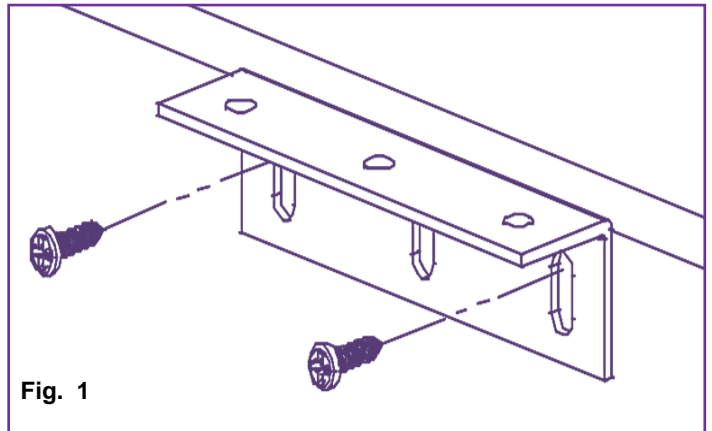

STEP 2: INSERT GLIDES AND SPACER TO PANELS

Insert 2 Glide Nuts (Item 9) each in the holes provided at the bottom edges on the Left and Right End panels and Screw the Hex-Base Glides (Item 10) each in the Glide Nut. (See Figure 2b).

Insert the Spacer (item 12) in the hole provided on the top of the Modesty Back panel (Item 3). (See Figure 2a).

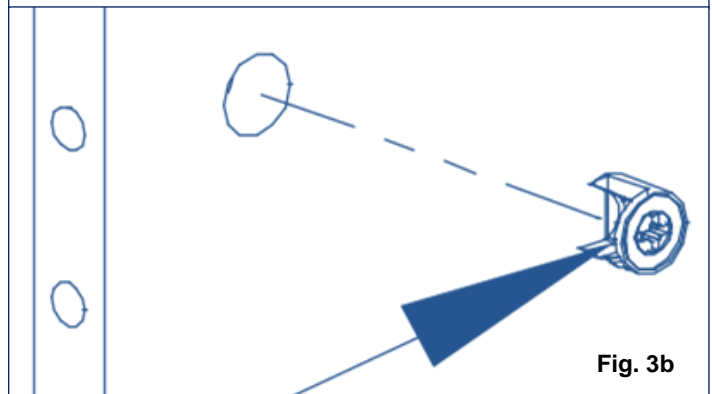
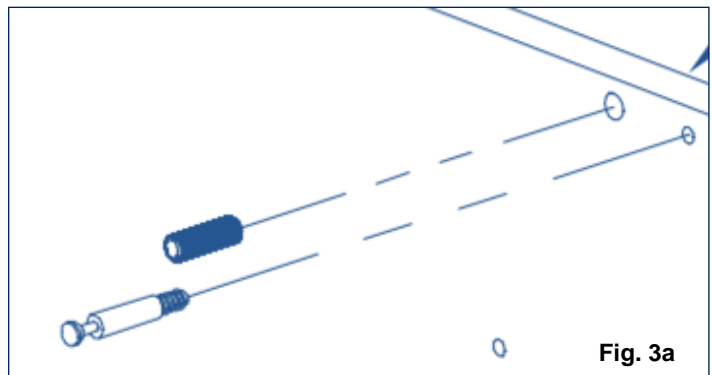
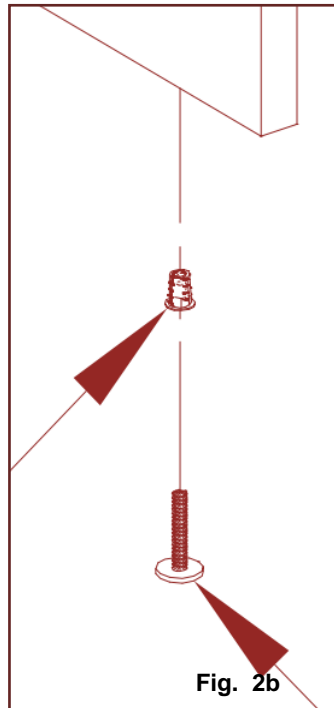
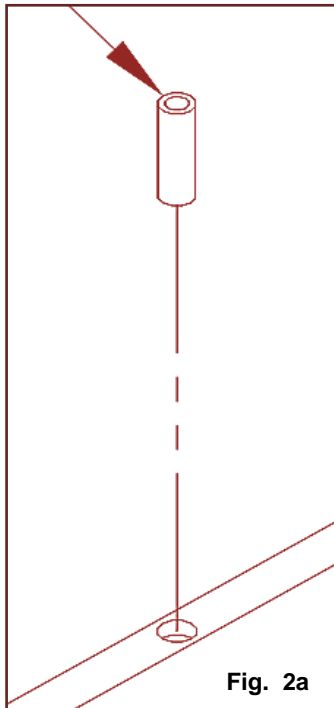

STEP 3: INSERT BOLTS, DOWELS AND CAM-LOCKS TO PANELS

Insert 4 cams (Item 7) each in the holes provided on the Modesty Panel (item 3) (See Fig. 3b). Insert 4 wood dowels (Item 8) and screw 4 Connecting Bolts (Item 6) each in the holes provided on Left and Right End panels (item 2) (See Figure 3a).

Place the Left and Right End panels at right angles on the Modesty Panel so that the Dowels and Bolts are inserted into the pre-drilled holes on the edge of the panels.

Twist-lock all the 8 cams with a Philips screw-driver to the Connecting bolts on the panels.

Your Base of the Desk with End panels and Modesty Panel should be assembled with 2 cleats each on the top of the Left and Right End panels.

STEP 4: ATTACH THE WORKSURFACE

Place the Worksurface (Item 1) on the base assembly so that the pre-installed Stiffener bracket (Item 4) is in the front of the desk

Attach the Worksurface to the base assembly with screws (Item 11) to the 4 steel cleats (previously fastened on the top of Left and Right End panels) (See Figure 4). Locate Top flush with back and outer edges of Left and Right End panel. Leave excess overhang to the front.

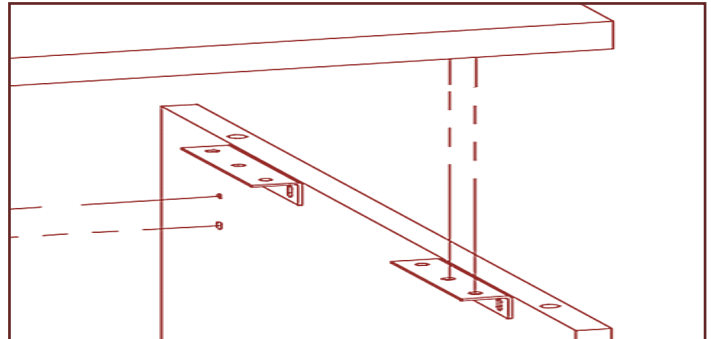



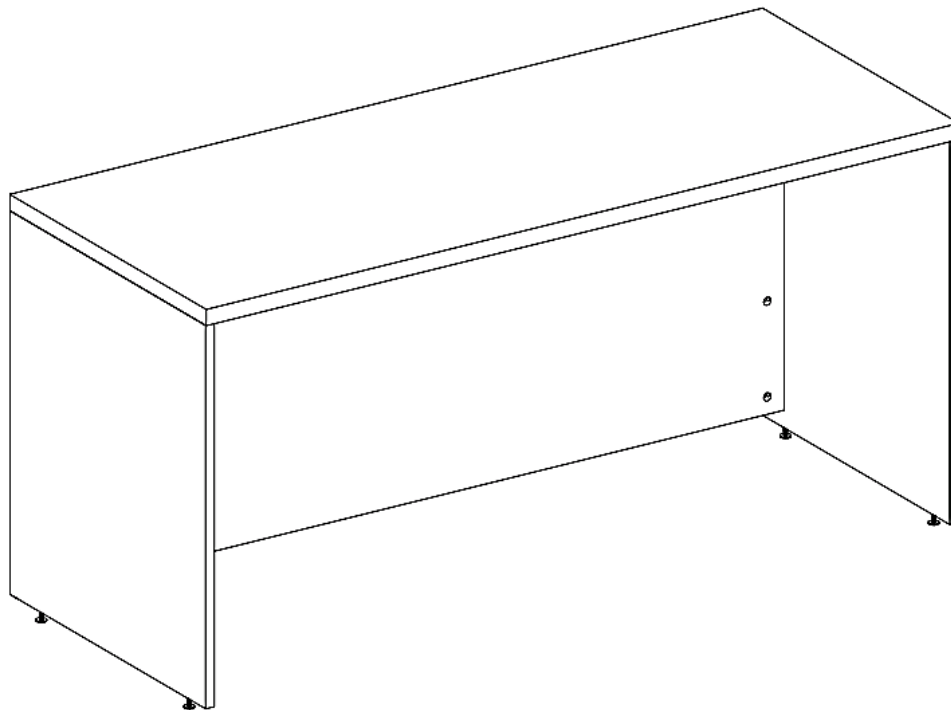



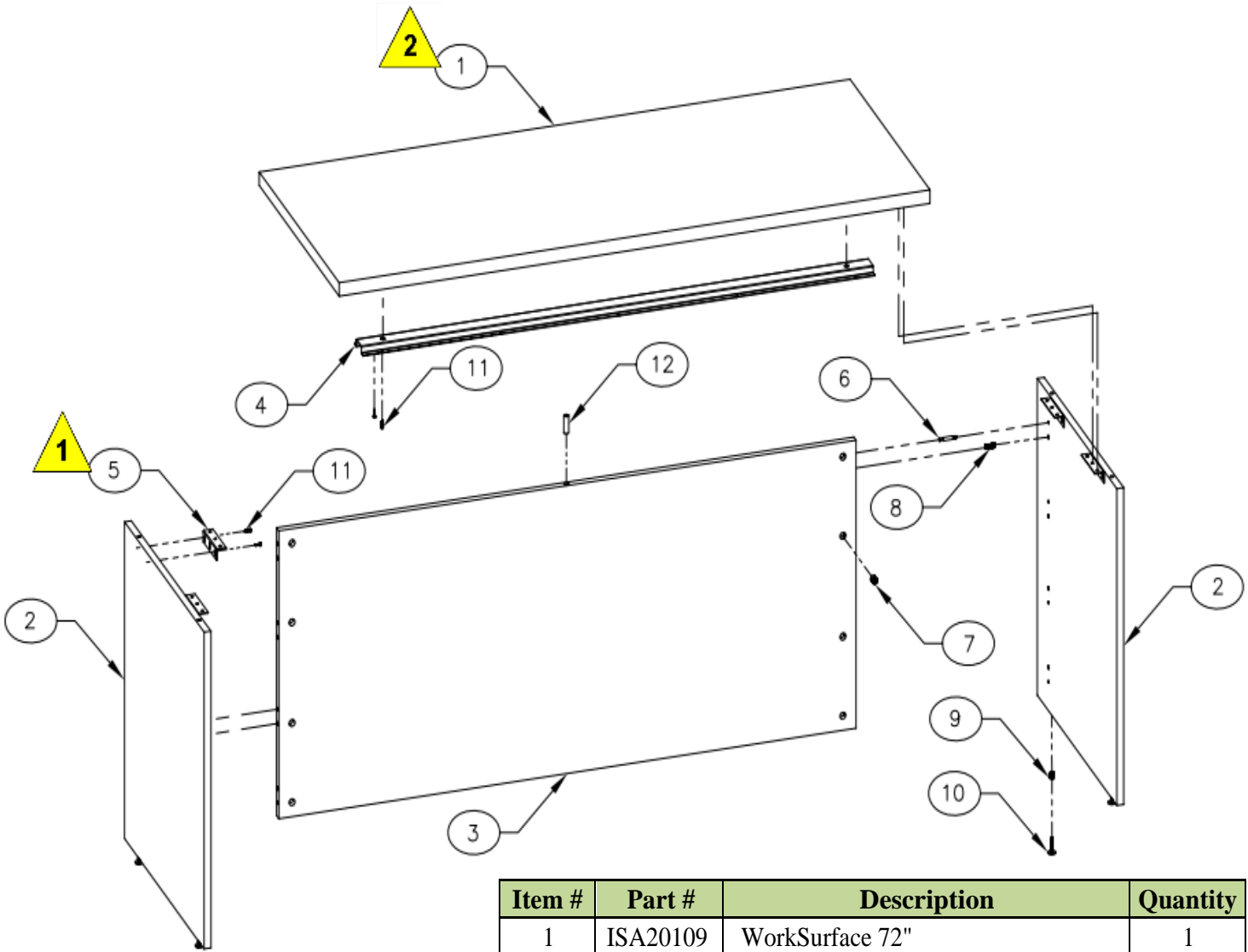

Your Final Assembled Product should look like below



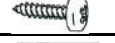

Integrate Assembly Instructions
Shell Credenza (72" x 24")
(Part No. I72CRSH)





Item #	Part #	Description	Quantity
1	ISA20109	WorkSurface 72"	1
2	ISA20015	End Panel Left/Right	2
3	ISA20017	Modesty Panel 72"	1
4	BKT1657	Stiffner Bracket for WorkSurface	1
5	BRB04411	Steel Cleats 	4
6	CTR21504	Bolts 	8
7	CTR21541	Cam Locks 	8
8	DWL0027	Dowel 1 Inch 	8
9	GLI0191	Insert Nuts for Glides 	4
10	GLI0212	Hex-Base Glides 	4
11	SCR2507	Screw 5/8Inch 	24
12	SPC4898	Spacer 	1

Warnings

-  Do not over-tighten the screws.
-  Do not turn cam-locks more than 180°.

Note

-  Space Cleats Evenly at top edge of inside face of panel
-  Locate Top flush with back and outer edges of End panels. Leave excess overhang to the front.
- Assembly should be performed on a clean flat floor.
- Verify all items are received before assembling.

Tools

- #2 Phillips Screwdriver
- 5mm wrench

STEP 1: ATTACH CLEATS TO THE END PANELS

Place the Left and Right End Panels (Item 2) on a flat surface. Space the 2 Steel Cleats (item 5) evenly on the top edge of inside face of each panel and fasten with the Screws (Item 11) to the End panels. (See Fig. 1)

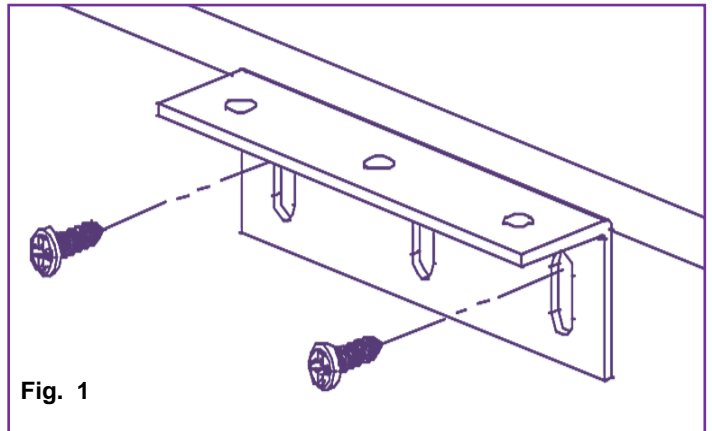

STEP 2: INSERT GLIDES AND SPACER TO PANELS

Insert 2 Glide Nuts (Item 9) each in the holes provided at the bottom edges on the Left and Right End panels and Screw the Hex-Base Glides (Item 10) each in the Glide Nut. (See Figure 2b).

Insert the Spacer (item 12) in the hole provided on the top of the Modesty Back panel (Item 3). (See Figure 2a).

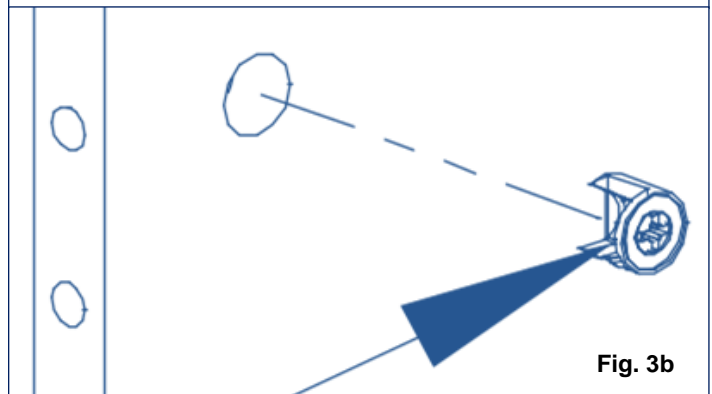
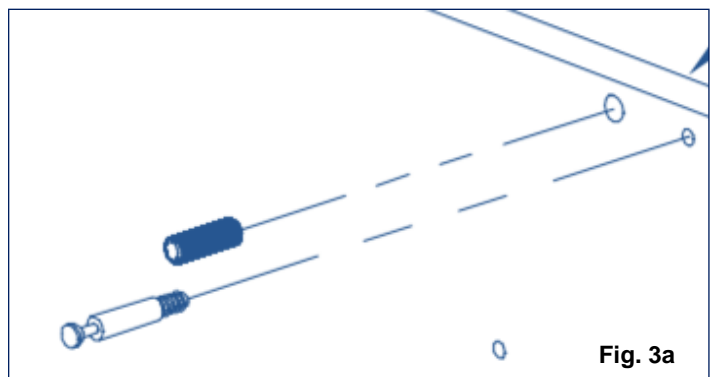
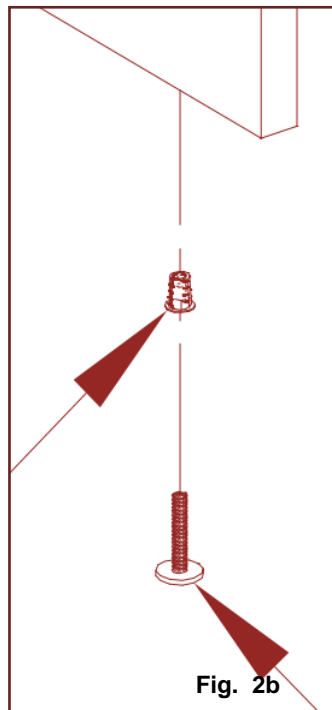
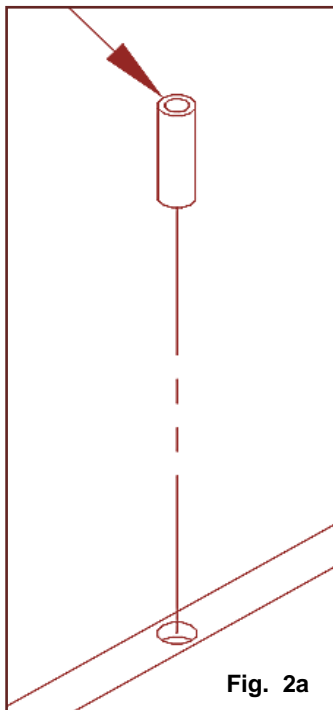

STEP 3: INSERT BOLTS, DOWELS AND CAM-LOCKS TO PANELS

Insert 4 cams (Item 7) each in the holes provided on the Modesty Panel (item 3) (See Fig. 3b). Insert 4 wood dowels (Item 8) and screw 4 Connecting Bolts (Item 6) each in the holes provided on Left and Right End panels (item 2) (See Figure 3a).

Place the Left and Right End panels at right angles on the Modesty Panel so that the Dowels and Bolts are inserted into the pre-drilled holes on the edge of the panels.

Twist-lock all the 8 cams with a Philips screw-driver to the Connecting bolts on the panels.

Your Base of the Desk with End panels and Modesty Panel should be assembled with 2 cleats each on the top of the Left and Right End panels.

STEP 4: ATTACH THE WORKSURFACE

Place the Worksurface (Item 1) on the base assembly so that the pre-installed Stiffener bracket (Item 4) is in the front of the desk

Attach the Worksurface to the base assembly with screws (Item 11) to the 4 steel cleats (previously fastened on the top of Left and Right End panels) (See Figure 4). Locate Top flush with back and outer edges of Left and Right End panel. Leave excess overhang to the front.

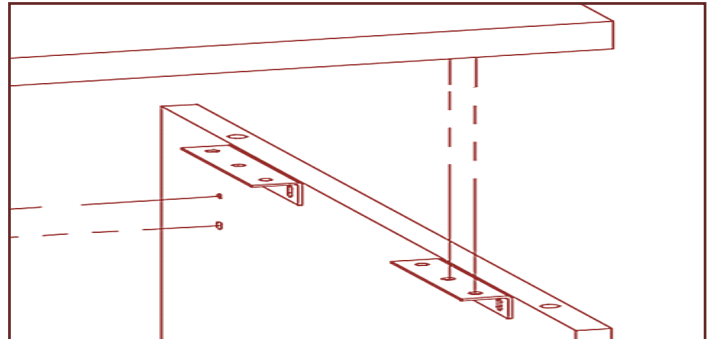



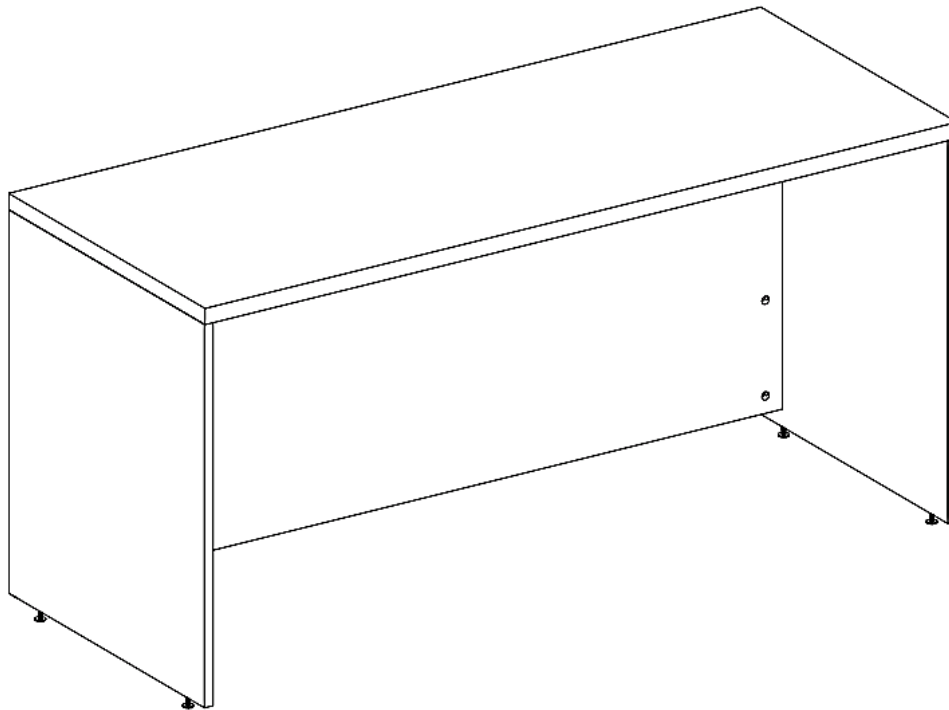

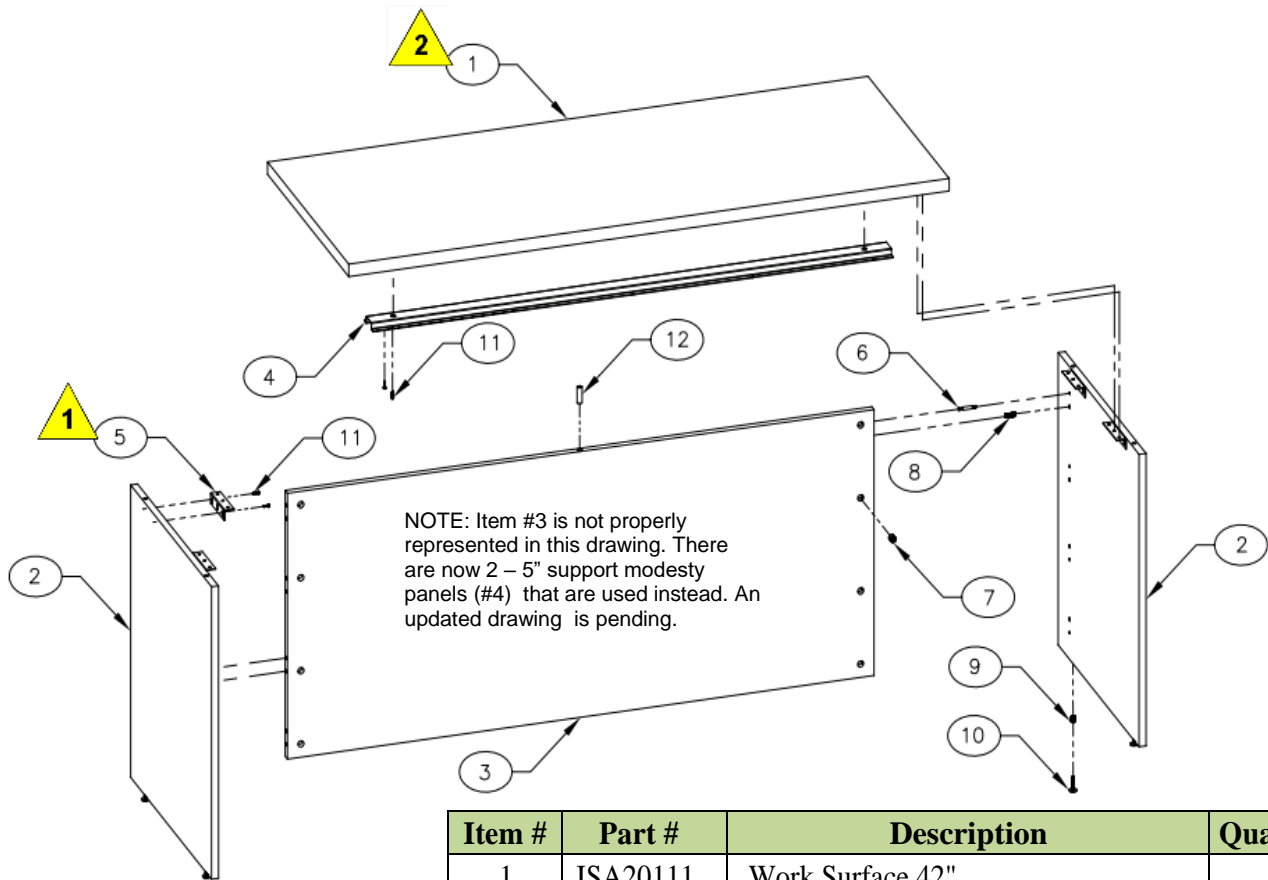

Your Final Assembled Product should look like below

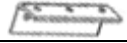



Integrate Assembly Instructions
Shell Credenza with Removable
Access Panel (42" x 24")
(Part No. I42CRSHAP)





Item #	Part #	Description	Quantity
1	ISA20111	Work Surface 42"	1
2	ISA20015	End Panel Left/Right	2
3	ISA20019	Removable Modesty Panel 42"	1
4		Fixed Support Modesty Panel 5"	2
5	BKT1657	Stiffener Bracket for	1
6	BRB0441	Steel Cleats 	4
7	CTR21504	Bolts 	8
8	CTR21541	Cam Locks 	8
9	DWL0027	Dowel 1 Inch 	8
10	GLI0191	Insert Nuts for Glides 	4
11	GLI0212	Hex-Base Glides 	4
12	SCR2507	Screw 5/8 Inch 	12
13	SCR9420	Screw 1 Inch	12
14	SCR9404	Screw 1/2 Inch	8
15	BKT99990	Bracket	4

Warnings

-  Do not over-tighten the screws.
-  Do not turn cam-locks more than 180°.

Note

-  Space Cleats Evenly at top edge of inside face of panel
-  Locate Top flush with back and outer edges of End panels. Leave excess overhang to the front.
- Assembly should be performed on a clean flat floor.
- Verify all items are received before assembling.

Tools

- # 2 Phillips Screwdriver
- 5mm wrench

**Integrate Assembly Instructions
Shell Credenza with Removable
Access Panel(42" x 24")**

(Part No. I42CRSHAP)

STEP 1: ATTACH CLEATS TO THE END PANELS

Place the Left and Right End Panels (Item 2) on a flat surface. Space the 2 Steel Cleats (item 5) evenly on the top edge of inside face of each panel and fasten with the Screws (Item 11) to the End panels. (See Fig. 1)

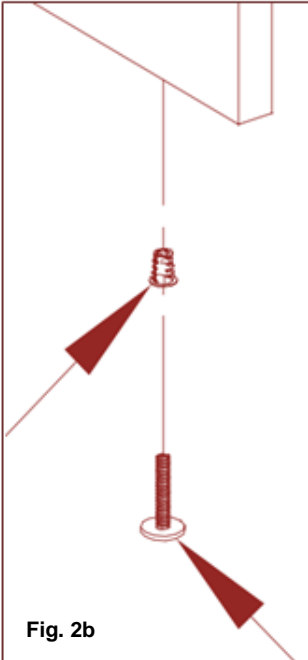
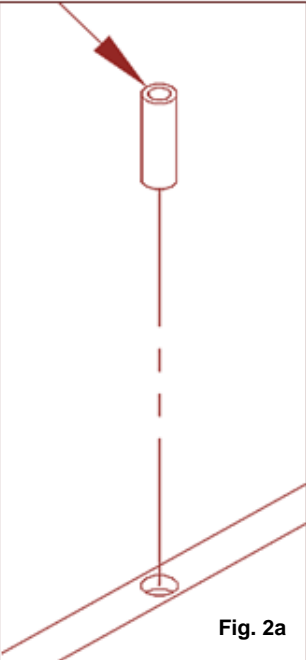
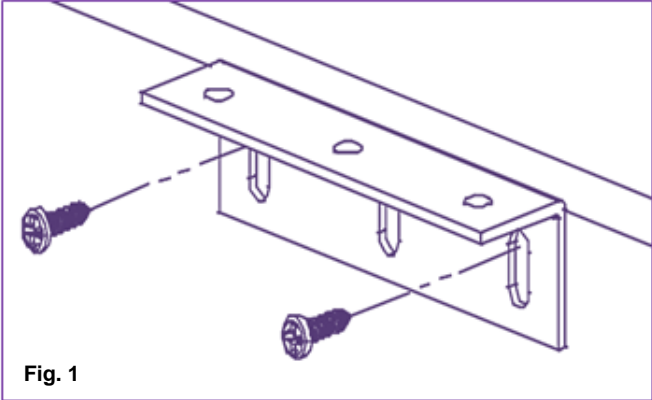

STEP 2: INSERT GLIDES AND SPACER TO PANELS

Insert 2 Glide Nuts (Item 9) each in the holes provided at the bottom edges on the Left and Right End panels and Screw the Hex-Base Glides (Item 10) each in the Glide Nut. (See Figure 2b).
Insert the Spacer (item 12) in the hole provided on the top of the Modesty Back panel (Item 3). (See Figure 2a).

STEP 3: INSERT BOLTS, DOWELS AND CAM-LOCKS TO PANELS

Insert 4 cams (Item 7) each in the holes provided on the 2 Fixed Support Modesty Panels (item 3) (See Fig. 3b). Insert 4 wood dowels (Item 8) and screw 4 Connecting Bolts (Item 6) each in the holes provided on Left and Right End panels (item 2) (See Figure 3a).
Place the Left and Right End panels at right angles on the Modesty Panels so that the Dowels and Bolts are inserted into the pre-drilled holes on the edge of the panels.
Twist-lock all the 8 cams with a Philips screw-driver to the Connecting bolts on the panels. The Base of the Desk with End panels and Modesty Panels should be assembled with 2 cleats each on the top of the Left and Right End panels.

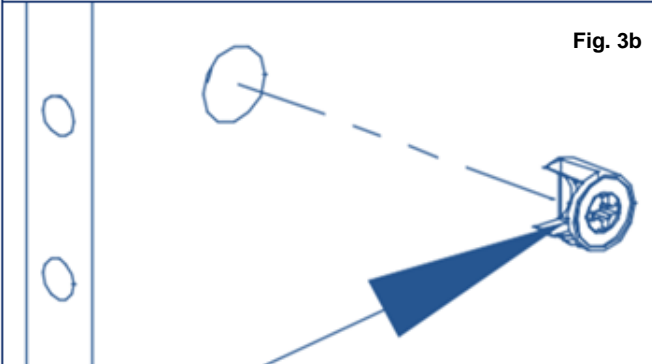
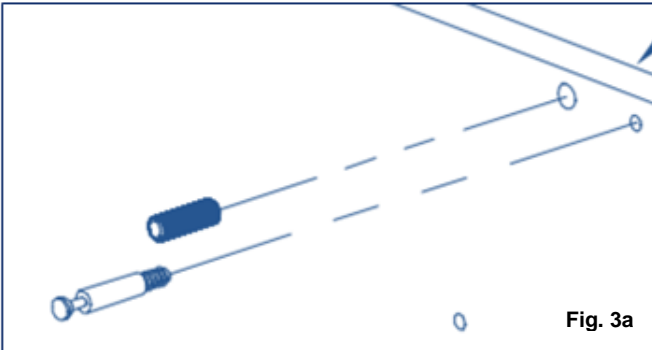

Integrate Assembly Instructions
Shell Credenza with Removable
Access Panel (42" x 24")

(Part No. I42CRSHAP)

Page 3 of 3

STEP 4: ATTACH THE WORKSURFACE

Place the Work Surface (Item 1) on the base assembly so that the pre-installed Stiffener bracket (Item 4) is in the front of the desk

Attach the Work Surface to the base assembly with screws (Item 11) to the 4 steel cleats (previously fastened on the top of Left and Right End panels) (See Figure 4). Locate Top flush with back and outer edges of Left and Right End panel. Leave excess overhang to the front.

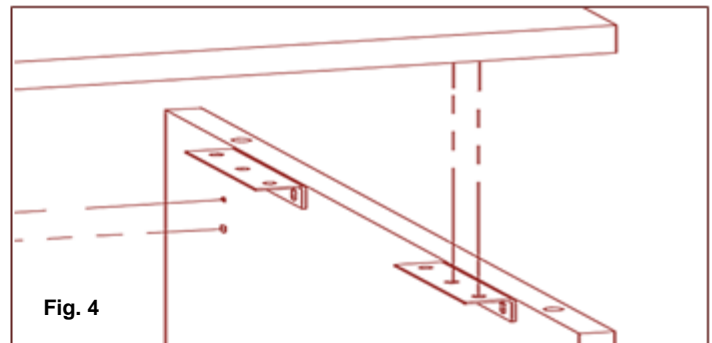
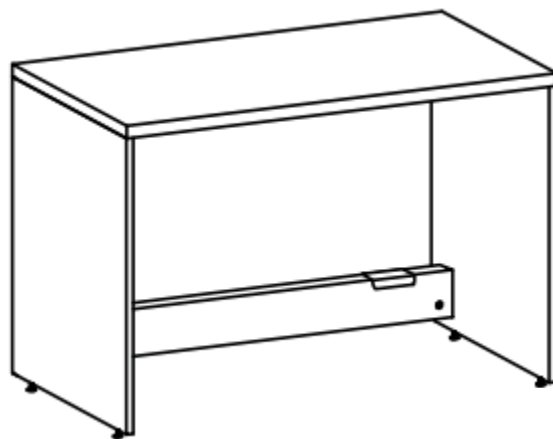

Fig. 4

STEP 5: HANG REMOVABLE ACCESS PANEL

Attach the 2 brackets to both the top and bottom of the Removable Modesty Panel with 1/2" screws in the pre-drilled holes.
Hang removable modesty panel on top and bottom of Fixed Support Modesty panels.







Your Final Assembled Product should look like below

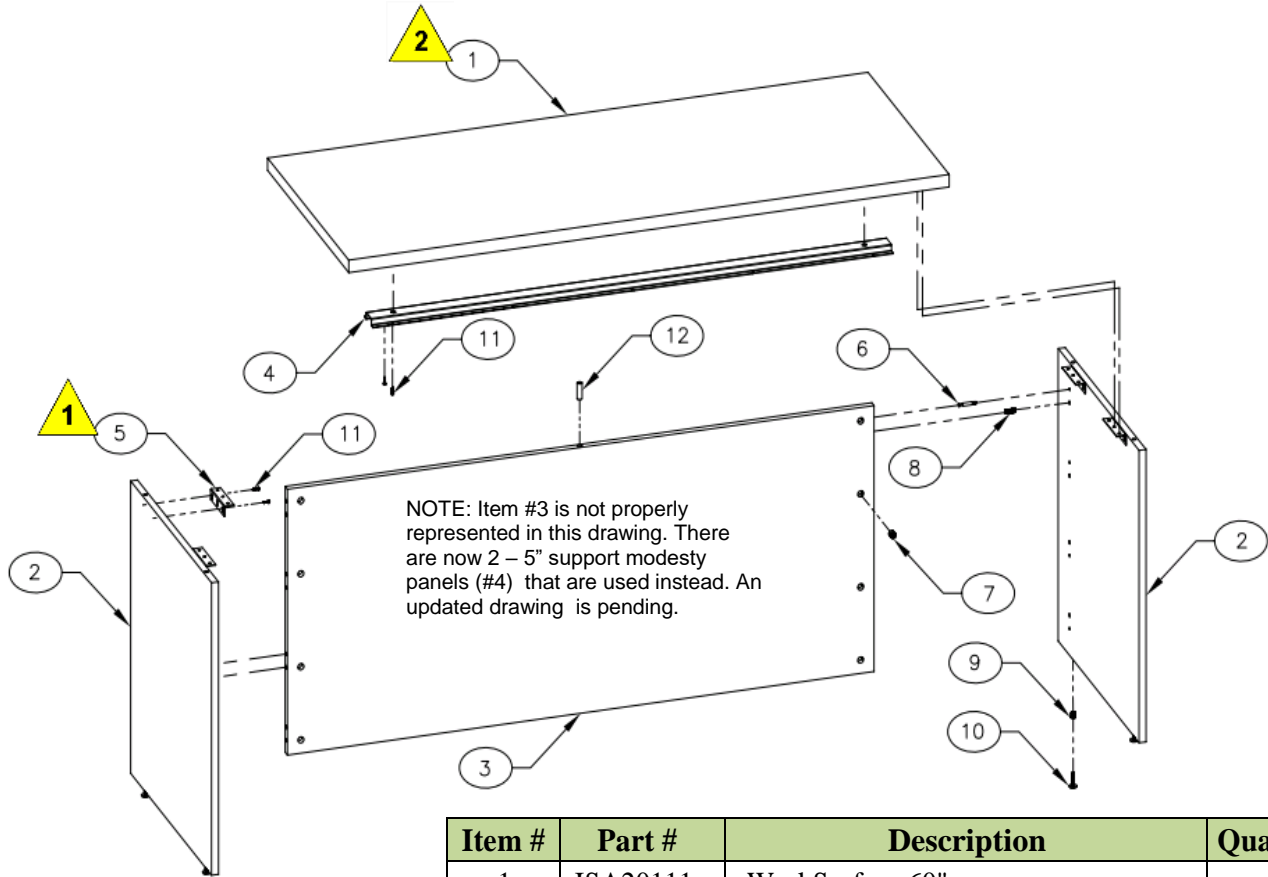

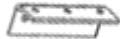

Integrate Assembly Instructions
Shell Credenza with Removable
Access Panel (60" x 24")

(Part No. I60CRSHAP)





Item #	Part #	Description	Quantity
1	ISA20111	WorkSurface 60"	1
2	ISA20015	End Panel Left/Right	2
3	ISA20019	Removable Modesty Panel 60"	1
4		Fixed Support Modesty Panel 5"	2
5	BKT1657	Stiffener Bracket for	1
6	BRB0441	Steel Cleats 	4
7	CTR21504	Bolts 	8
8	CTR21541	Cam Locks 	8
9	DWL0027	Dowel 1 Inch 	8
10	GLI0191	Insert Nuts for Glides 	4
11	GLI0212	Hex-Base Glides 	4
12	SCR2507	Screw 5/8 Inch 	12
13	SCR9420	Screw 1 Inch	12
14	SCR9404	Screw 1/2 Inch	8
15	BKT99990	Bracket	4

Warnings

-  Do not over-tighten the screws.
-  Do not turn cam-locks more than 180°.

Note

 Space Cleats Evenly at top edge of inside face of panel

 Locate Top flush with back and outer edges of End panels. Leave excess overhang to the front.

- Assembly should be performed on a clean flat floor.
- Verify all items are received before assembling.

Tools

- #2 Phillips Screwdriver
- 5mm wrench

**Integrate Assembly Instructions
Shell Credenza with Removable
Access Panel (60" x 24")**

(Part No. I60CRSHAP)

STEP 1: ATTACH CLEATS TO THE END PANELS

Place the Left and Right End Panels (Item 2) on a flat surface. Space the 2 Steel Cleats (item 5) evenly on the top edge of inside face of each panel and fasten with the Screws (Item 11) to the End panels. (See Fig. 1)

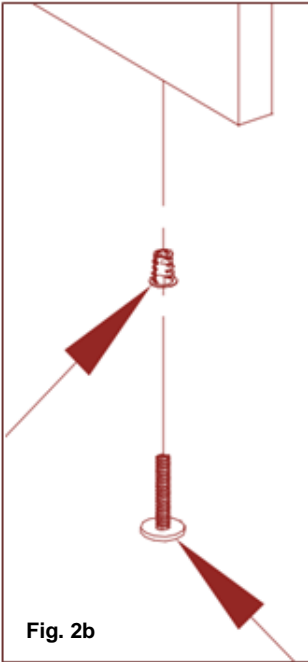
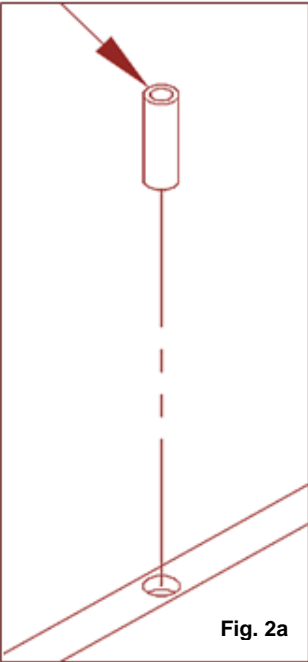
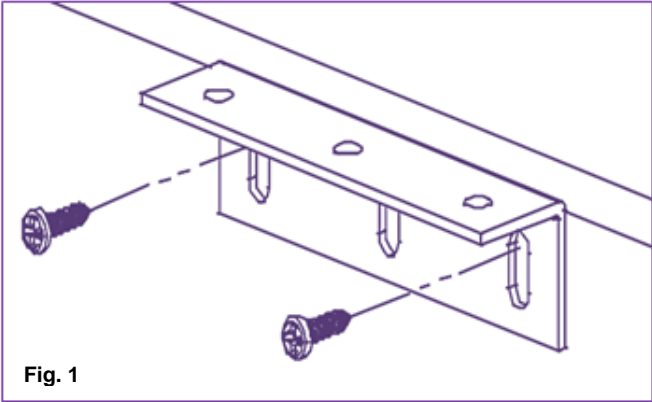

STEP 2: INSERT GLIDES AND SPACER TO PANELS

Insert 2 Glide Nuts (Item 9) each in the holes provided at the bottom edges on the Left and Right End panels and Screw the Hex-Base Glides (Item 10) each in the Glide Nut. (See Figure 2b).
Insert the Spacer (item 12) in the hole provided on the top of the Modesty Back panel (Item 3). (See Figure 2a).

STEP 3: INSERT BOLTS, DOWELS AND CAM-LOCKS TO PANELS

Insert 4 cams (Item 7) each in the holes provided on the 2 Fixed Support Modesty Panels (item 3) (See Fig. 3b). Insert 4 wood dowels (Item 8) and screw 4 Connecting Bolts (Item 6) each in the holes provided on Left and Right End panels (item 2) (See Figure 3a).

Place the Left and Right End panels at right angles on the Modesty Panels so that the Dowels and Bolts are inserted into the pre-drilled holes on the edge of the panels.

Twist-lock all the 8 cams with a Philips screw-driver to the Connecting bolts on the panels. The Base of the Desk with End panels and Modesty Panels should be assembled with 2 cleats each on the top of the Left and Right End panels.

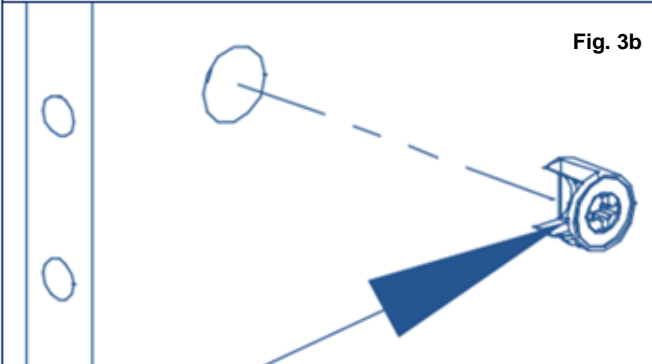
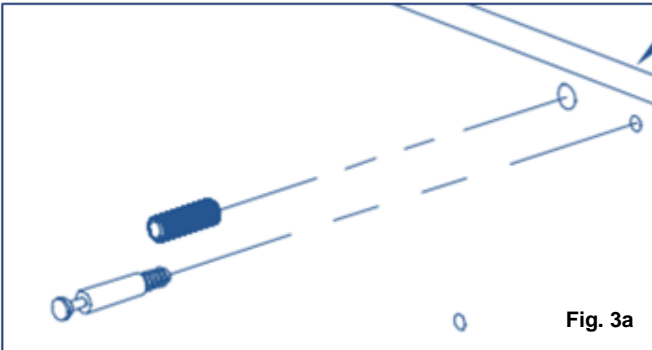

Integrate Assembly Instructions
Shell Credenza with Removable
Access Panel (60" x 24")

(Part No. I60CRSHAP)

Page 3 of 3

STEP 4: ATTACH THE WORKSURFACE

Place the Work Surface (Item 1) on the base assembly so that the pre-installed Stiffener bracket (Item 4) is in the front of the desk

Attach the Work Surface to the base assembly with screws (Item 11) to the 4 steel cleats (previously fastened on the top of Left and Right End panels) (See Figure 4). Locate Top flush with back and outer edges of Left and Right End panel. Leave excess overhang to the front.

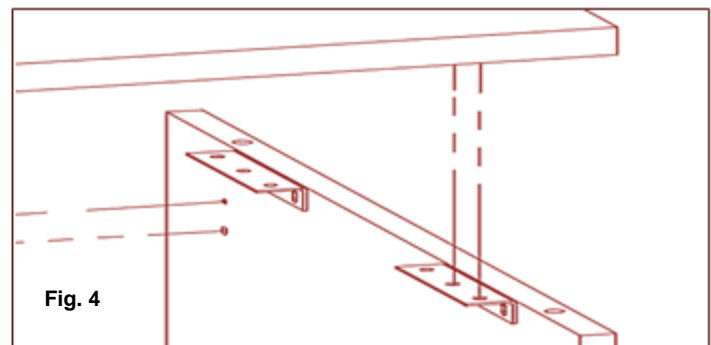
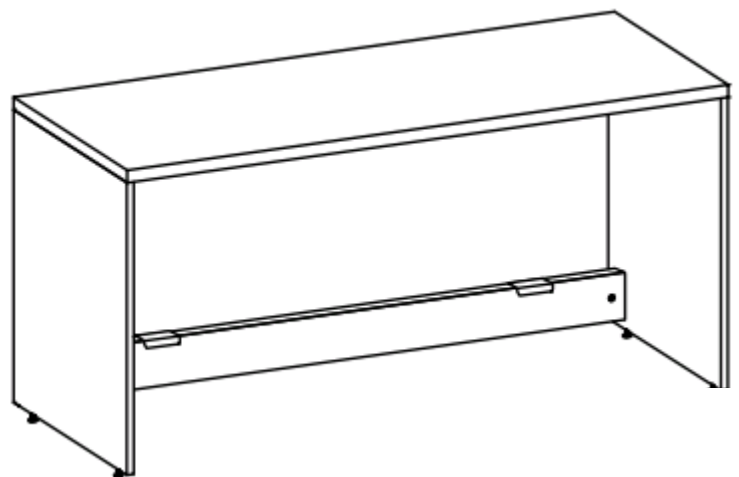

Fig. 4

STEP 5: HANG REMOVABLE ACCESS PANEL

Attach the 2 brackets to both the top and bottom of the Removable Modesty Panel with 1/2" screws in the pre-drilled holes.
Hang removable modesty panel on top and bottom of Fixed Support Modesty panels.

Your Final Assembled Product should look like below







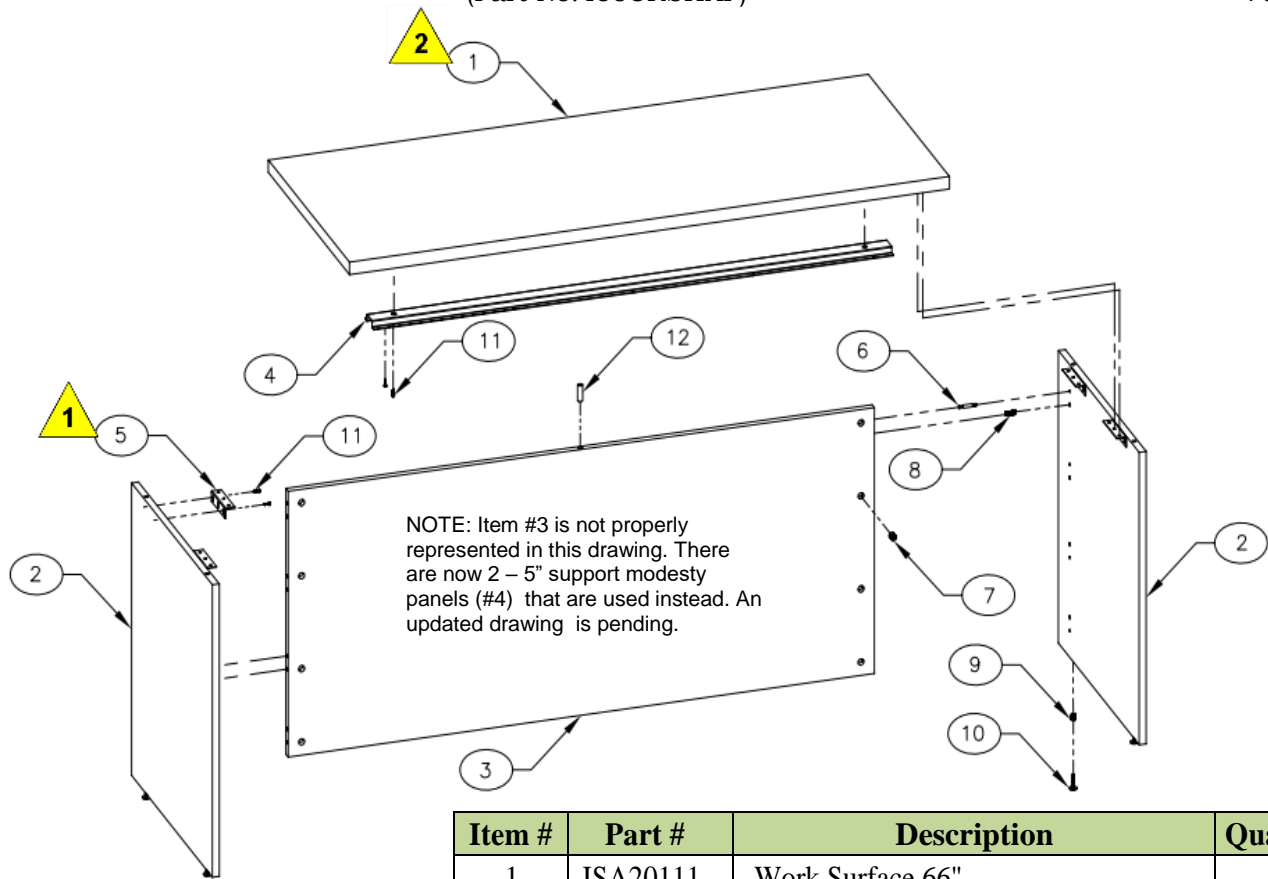

Integrate Assembly Instructions
Shell Credenza with Removable
Access Panel (66" x 24")

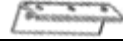

(Part No. I66CRSHAP)

Page 1 of 3





Item #	Part #	Description	Quantity
1	ISA20111	Work Surface 66"	1
2	ISA20015	End Panel Left/Right	2
3	ISA20019	Removable Modesty Panel 66"	1
4		Fixed Support Modesty Panel 5"	2
5	BKT1657	Stiffener Bracket for	1
6	BRB0441	Steel Cleats 	4
7	CTR21504	Bolts 	8
8	CTR21541	Cam Locks 	8
9	DWL0027	Dowel 1 Inch 	8
10	GLI0191	Insert Nuts for Glides 	4
11	GLI0212	Hex-Base Glides 	4
12	SCR2507	Screw 5/8 Inch 	12
13	SCR9420	Screw 1 Inch	12
14	SCR9404	Screw 1/2 Inch	8
15	BKT99990	Bracket	4

Warnings

-  Do not over-tighten the screws.
-  Do not turn cam-locks more than 180°.

Note

-  Space Cleats Evenly at top edge of inside face of panel
-  Locate Top flush with back and outer edges of End panels. Leave excess overhang to the front.
- Assembly should be performed on a clean flat floor.
- Verify all items are received before assembling.

Tools

- # 2 Phillips Screwdriver
- 5mm wrench

**Integrate Assembly Instructions
Shell Credenza with Removable
Access Panel (66" x 24")**

(Part No. I66CRSHAP)

STEP 1: ATTACH CLEATS TO THE END PANELS

Place the Left and Right End Panels (Item 2) on a flat surface. Space the 2 Steel Cleats (item 5) evenly on the top edge of inside face of each panel and fasten with the Screws (Item 11) to the End panels. (See Fig. 1)

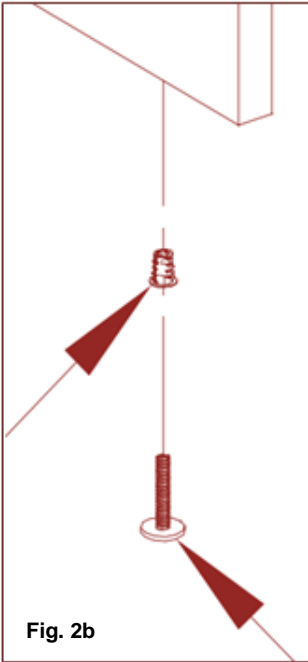
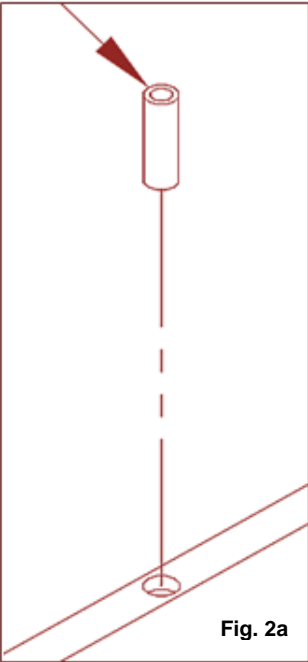
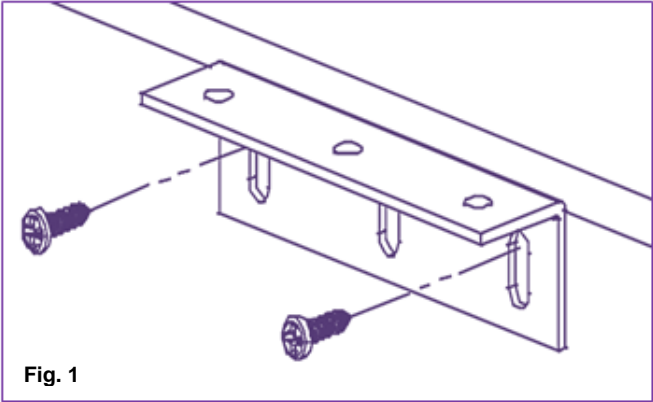

STEP 2: INSERT GLIDES AND SPACER TO PANELS

Insert 2 Glide Nuts (Item 9) each in the holes provided at the bottom edges on the Left and Right End panels and Screw the Hex-Base Glides (Item 10) each in the Glide Nut. (See Figure 2b).
Insert the Spacer (item 12) in the hole provided on the top of the Modesty Back panel (Item 3). (See Figure 2a).

STEP 3: INSERT BOLTS, DOWELS AND CAM-LOCKS TO PANELS

Insert 4 cams (Item 7) each in the holes provided on the 2 Fixed Support Modesty Panels (item 3) (See Fig. 3b). Insert 4 wood dowels (Item 8) and screw 4 Connecting Bolts (Item 6) each in the holes provided on Left and Right End panels (item 2) (See Figure 3a).

Place the Left and Right End panels at right angles on the Modesty Panels so that the Dowels and Bolts are inserted into the pre-drilled holes on the edge of the panels.

Twist-lock all the 8 cams with a Philips screw-driver to the Connecting bolts on the panels. The Base of the Desk with End panels and Modesty Panels should be assembled with 2 cleats each on the top of the Left and Right End panels.

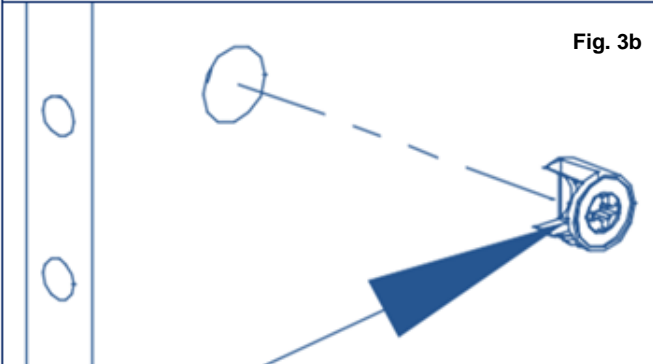
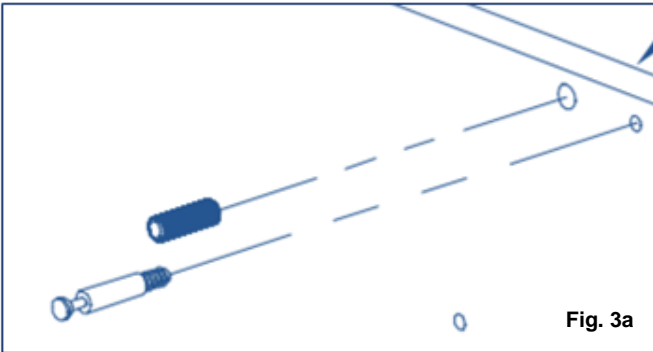

Integrate Assembly Instructions
Shell Credenza with Removable
Access Panel (66" x 24")

(Part No. I66CRSHAP)

Page 3 of 3

STEP 4: ATTACH THE WORKSURFACE

Place the Work Surface (Item 1) on the base assembly so that the pre-installed Stiffener bracket (Item 4) is in the front of the desk

Attach the Work Surface to the base assembly with screws (Item 11) to the 4 steel cleats (previously fastened on the top of Left and Right End panels) (See Figure 4). Locate Top flush with back and outer edges of Left and Right End panel. Leave excess overhang to the front.

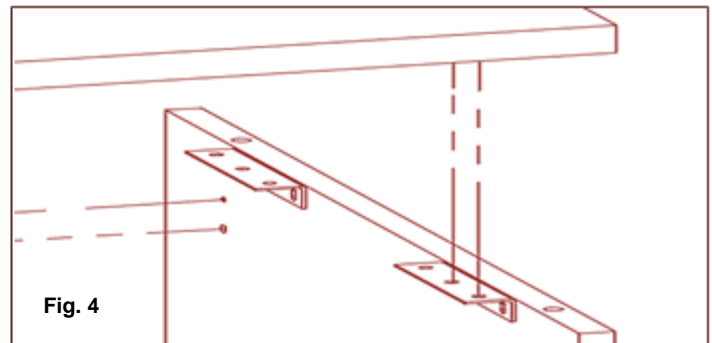

STEP 5: HANG REMOVABLE ACCESS PANEL

Attach the 2 brackets to both the top and bottom of the Removable Modesty Panel with 1/2" screws in the pre-drilled holes. Hang removable modesty panel on top and bottom of Fixed Support Modesty panels.



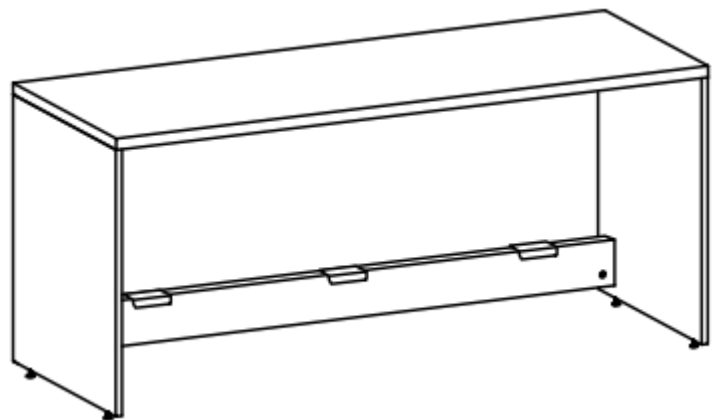



Your Final Assembled Product should look like below

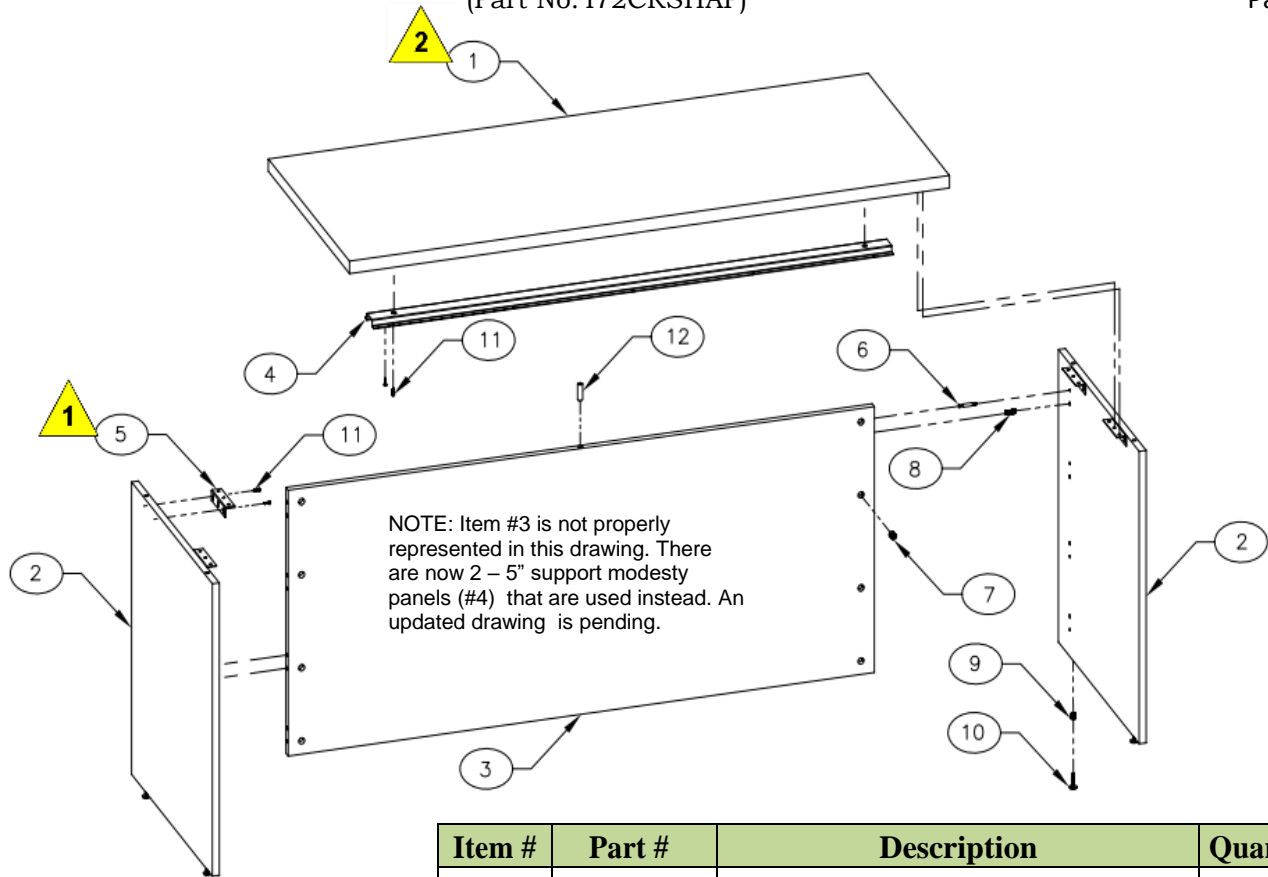

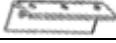
Integrate Assembly Instructions
Shell Credenza with Removable
Access Panel (72" x 24")

(Part No. I72CRSHAP)





Item #	Part #	Description	Quantity
1	ISA20111	Work Surface 72"	1
2	ISA20015	End Panel Left/Right	2
3	ISA20019	Removable Modesty Panel 72"	1
4		Fixed Support Modesty Panel 5"	2
5	BKT1657	Stiffener Bracket for	1
6	BRB0441	Steel Cleats 	4
7	CTR21504	Bolts 	8
8	CTR21541	Cam Locks 	8
9	DWL0027	Dowel 1 Inch 	8
10	GLI0191	Insert Nuts for Glides 	4
11	GLI0212	Hex-Base Glides 	4
12	SCR2507	Screw 5/8 Inch 	12
13	SCR9420	Screw 1 Inch	12
14	SCR9404	Screw 1/2 Inch	8
15	BKT99990	Bracket	4

Warnings

-  Do not over-tighten the screws.
- Do not turn cam-locks more than 180°.

Note

 Space Cleats Evenly at top edge of inside face of panel

 Locate Top flush with back and outer edges of End panels. Leave excess overhang to the front.

- Assembly should be performed on a clean flat floor.
- Verify all items are received before assembling.

Tools

- # 2 Phillips Screwdriver
- 5mm wrench

**Integrate Assembly Instructions
Shell Credenza with Removable
Access Panel (72" x 24")**

(Part No. I72CRSHAP)

STEP 1: ATTACH CLEATS TO THE END PANELS

Place the Left and Right End Panels (Item 2) on a flat surface. Space the 2 Steel Cleats (item 5) evenly on the top edge of inside face of each panel and fasten with the Screws (Item 11) to the End panels. (See Fig. 1)

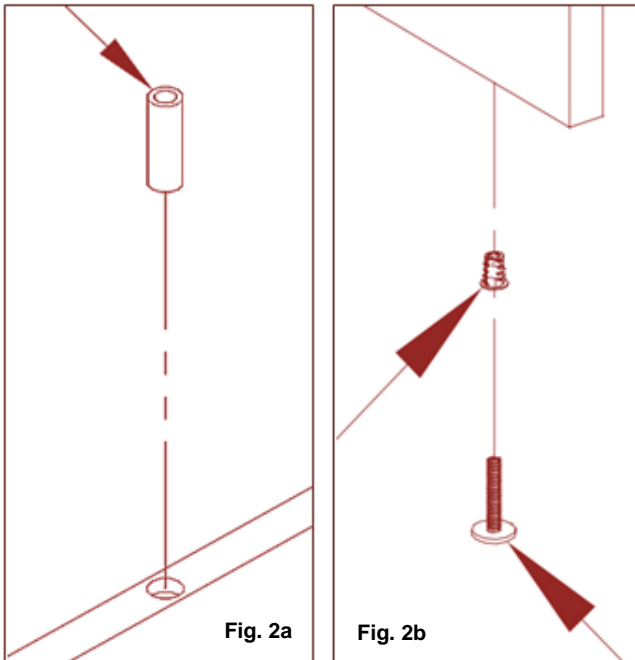
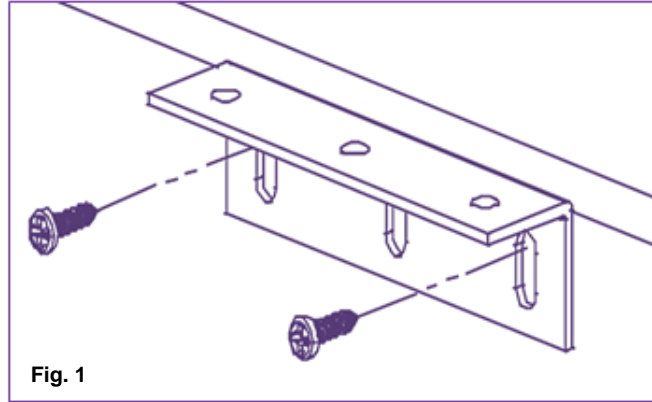

STEP 2: INSERT GLIDES AND SPACER TO PANELS

Insert 2 Glide Nuts (Item 9) each in the holes provided at the bottom edges on the Left and Right End panels and Screw the Hex-Base Glides (Item 10) each in the Glide Nut. (See Figure 2b).

Insert the Spacer (item 12) in the hole provided on the top of the Modesty Back panel (Item 3). (See Figure 2a).

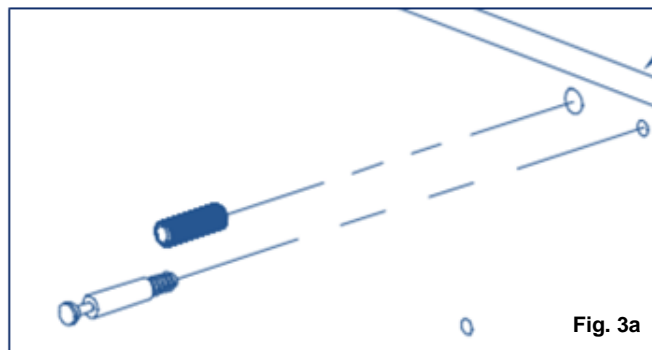

STEP 3: INSERT BOLTS, DOWELS AND CAM-LOCKS TO PANELS

Insert 4 cams (Item 7) each in the holes provided on the 2 Fixed Support Modesty Panels (item 3) (See Fig. 3b). Insert 4 wood dowels (Item 8) and screw 4 Connecting Bolts (Item 6) each in the holes provided on Left and Right End panels (item 2) (See Figure 3a).

Place the Left and Right End panels at right angles on the Modesty Panels so that the Dowels and Bolts are inserted into the pre-drilled holes on the edge of the panels.

Twist-lock all the 8 cams with a Philips screw-driver to the Connecting bolts on the panels. The Base of the Desk with End panels and Modesty Panels should be assembled with 2 cleats each on the top of the Left and Right End panels.

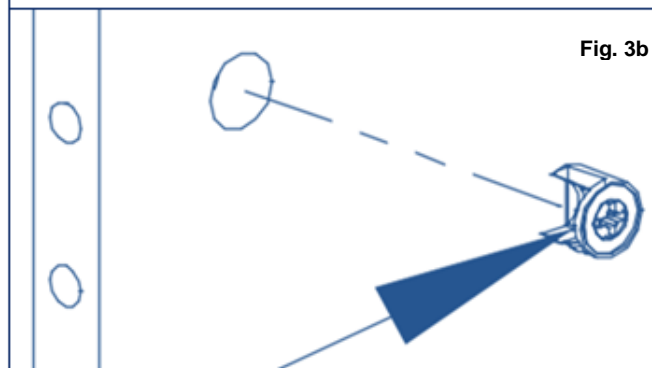

Integrate Assembly Instructions
Shell Credenza with Removable
Access Panel (72" x 24")

(Part No. I72CRSHAP)

Page 3 of 3

STEP 4: ATTACH THE WORKSURFACE

Place the Work Surface (Item 1) on the base assembly so that the pre-installed Stiffener bracket (Item 4) is in the front of the desk

Attach the Work Surface to the base assembly with screws (Item 11) to the 4 steel cleats (previously fastened on the top of Left and Right End panels) (See Figure 4). Locate Top flush with back and outer edges of Left and Right End panel. Leave excess overhang to the front.

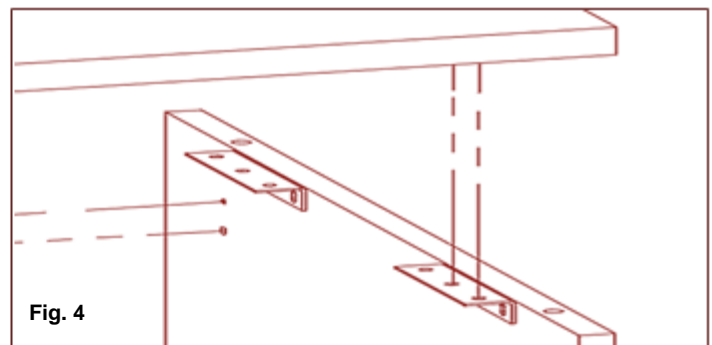
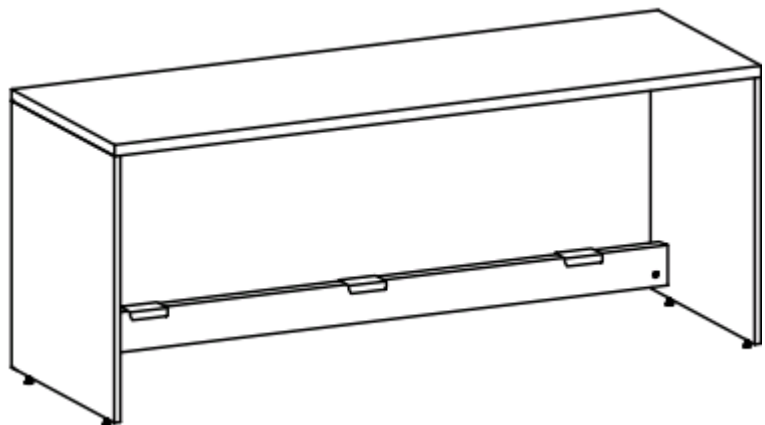

Fig. 4

STEP 5: HANG REMOVABLE ACCESS PANEL







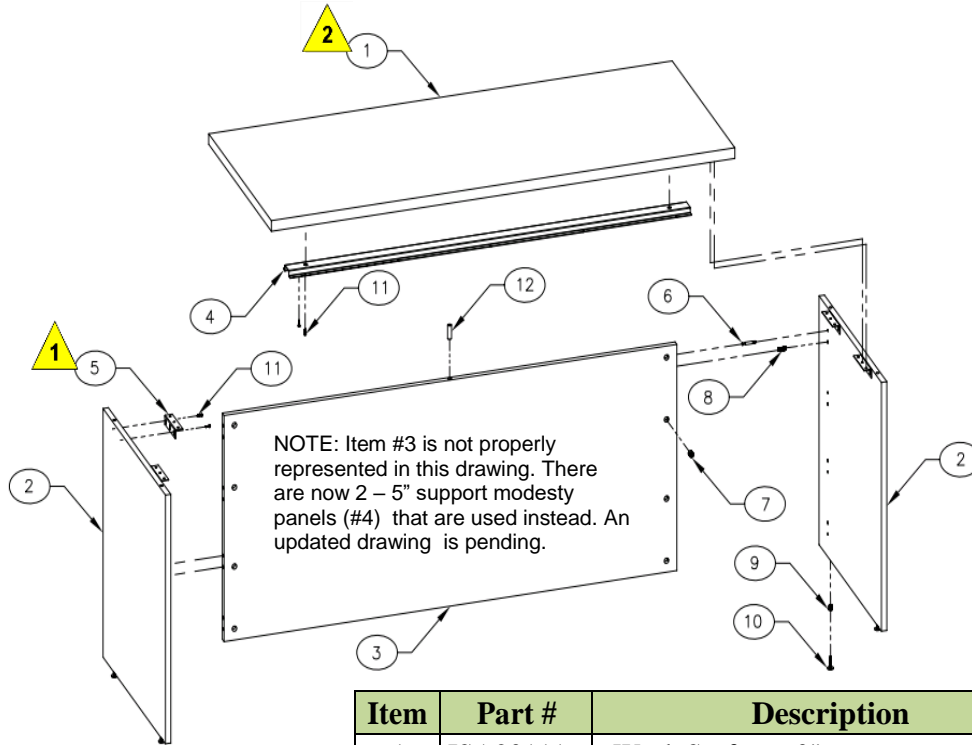

Attach the 2 brackets to both the top and bottom of the Removable Modesty Panel with 1/2" screws in the pre-drilled holes. Hang removable modesty panel on top and bottom of Fixed Support Modesty panels.

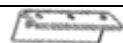
Your Final Assembled Product should look like below



Integrate Assembly Instructions
Shell Desk with Removable
Access Panel (42" x 30")
(Part No. I42DKSHAP)



Item	Part #	Description	Quantity
1	ISA20111	Work Surface 60"	1
2	ISA20015	End Panel Left/Right	2
3	ISA20019	Removable Modesty Panel 60"	1
4		Fixed Support Modesty Panel 5"	2
5	BKT1657	Stiffener Bracket for	1
6	BRB04411	Steel Cleats 	4
7	CTR21504	Bolts 	8
8	CTR21541	Cam Locks 	8
9	DWL0027	Dowel 1 Inch 	8
10	GLI0191	Insert Nuts for Glides 	4
11	GLI0212	Hex-Base Glides 	4
12	SPC4898	Spacer 	1
13	SCR2507	Screw 5/8 Inch 	12
14	SCR9420	Screw 1 Inch	12
15	SCR9404	Screw 1/2 Inch	8
16	BKT99990	Bracket	4

Warnings

Do not over-tighten the screws
Do not turn cam locks more than 180°



NOTE
⚠ Space Cleats Evenly at top edge of inside face of panel

⚠ Locate Top flush with back and outer edges of End panels. Leave excess overhang to the front.

Assembly should be performed on a clean flat floor.

Verify all items are received before assembling.

Tools

- # 2 Phillips Screwdriver
- 5mm wrench

**Integrate Assembly Instructions
Shell Desk with Removable
Access Panel (42" x 30")**

(Part No. I42DKSHAP)

STEP 1: ATTACH CLEATS TO THE END PANELS

Place the Left and Right End Panels (Item 2) on a flat surface. Space the 2 Steel Cleats (item 5) evenly on the top edge of inside face of each panel and fasten with the Screws (Item 11) to the End panels. (See Fig. 1)

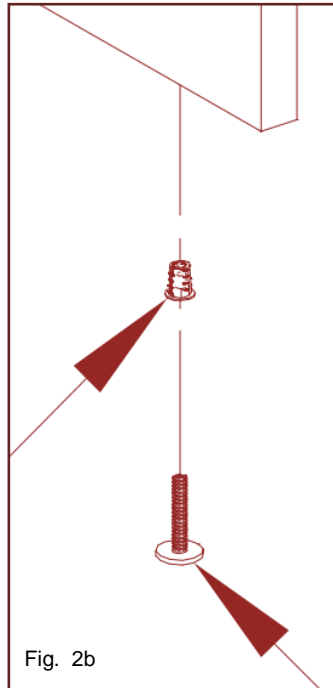
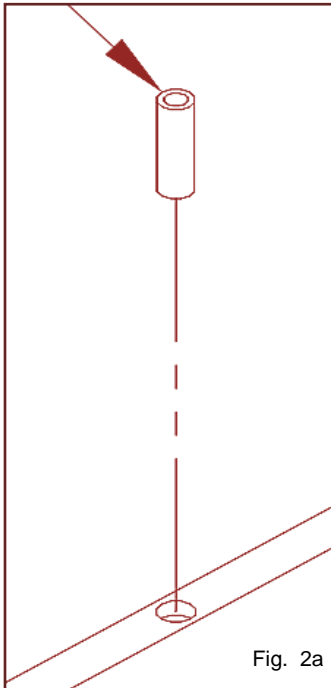
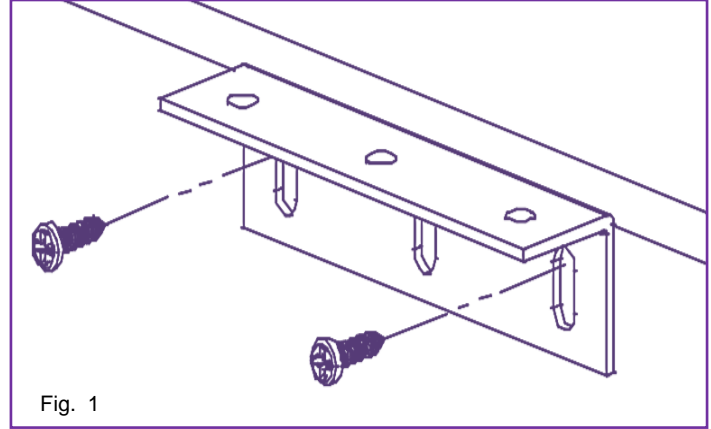

STEP 2: INSERT GLIDES AND SPACER TO PANELS

Insert 2 Glide Nuts (Item 9) each in the holes provided at the bottom edges on the Left and Right End panels and Screw the Hex-Base Glides (Item 10) each in the Glide Nut. (See Figure 2b).

Insert the Spacer (item 12) in the hole provided on the top of the Modesty Back panel (Item 3). (See Figure 2a).

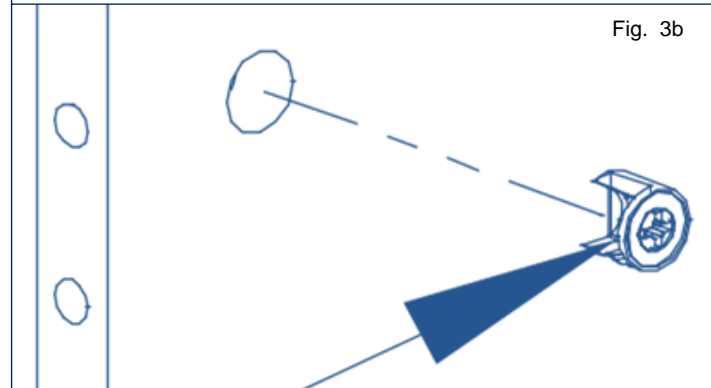
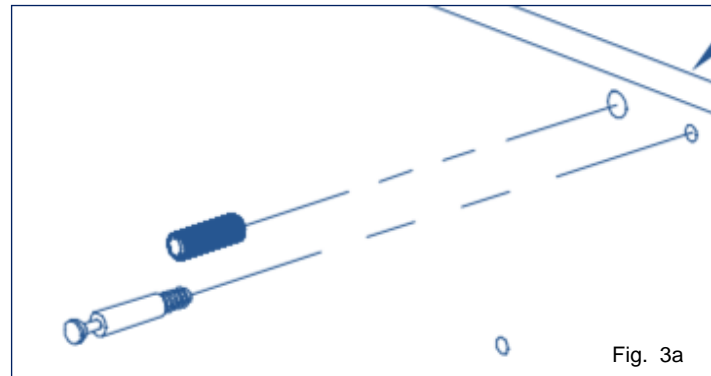

STEP 3: INSERT BOLTS, DOWELS AND CAM-LOCKS TO PANELS

Insert 4 cams (Item 7) each in the holes provided on the Modesty Panel (item 3) (See Fig. 3b). Insert 4 wood dowels (Item 8) and screw 4 Connecting Bolts (Item 6) each in the holes provided on Left and Right End panels (item 2) (See Figure 3a).

Place the Left and Right End panels at right angles on the Modesty Panel so that the Dowels and Bolts are inserted into the pre-drilled holes on the edge of the panels.

Twist-lock all the 8 cams with a Philips screw-driver to the Connecting bolts on the panels.

The Base of the Desk with End panels and Fixed Support Modesty Panels should be assembled with 2 cleats each on the top of the Left and Right End panels.

Integrate Assembly Instructions
Shell Desk with Removable
Access Panel (42" x 30")

(Part No. I42DKSHAP)

Page 3 of 3

STEP 4: ATTACH THE WORKSURFACE

Place the Work Surface (Item 1) on the base assembly so that the pre-installed Stiffener bracket (Item 4) is in the front of the desk

Attach the Work Surface to the base assembly with screws (Item 11) to the 4 steel cleats (previously fastened on the top of Left and Right End panels) (See Figure 4). Locate Top flush with back and outer edges of Left and Right End panel. Leave excess overhang to the front.

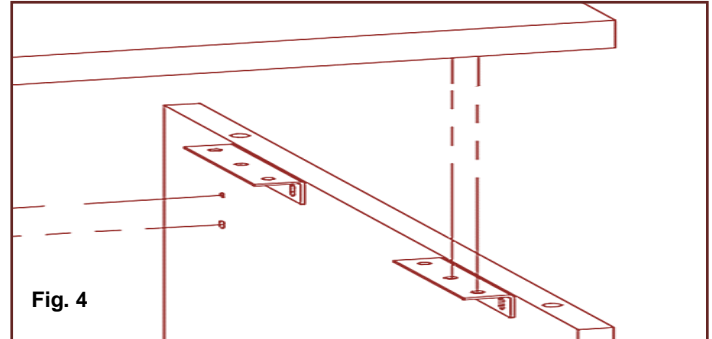

STEP 5: HANG REMOVABLE ACCESS PANEL

Attach the 2 brackets to both the top and bottom of the Removable Modesty Panel with $\frac{1}{2}$ " screws in the pre-drilled holes. Hang removable modesty panel on top and bottom of Fixed Support Modesty panels.



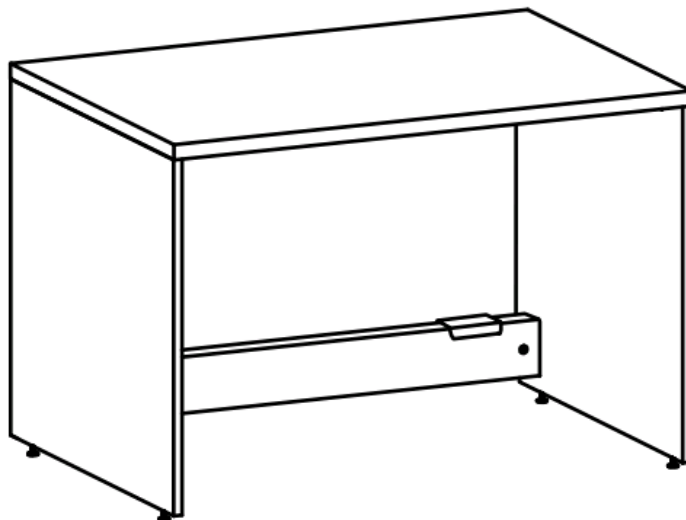



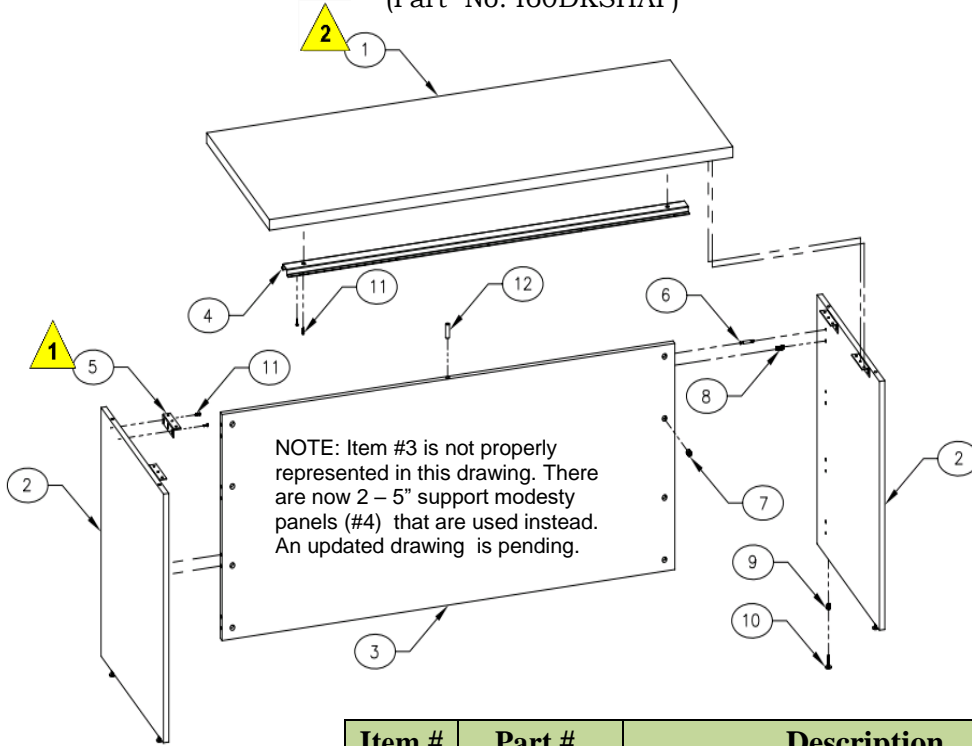

Your Final Assembled Product should look like below

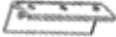

Integrate Assembly Instructions
Shell Desk with Removable
Access Panel (60" x 30")

(Part No. I60DKSHAP)





Item #	Part #	Description	Quantity
1	ISA20111	Work Surface 60"	1
2	ISA20015	End Panel Left/Right	2
3	ISA20019	Removable Modesty Panel 60"	1
4		Fixed Support Modesty Panel 5"	2
5	BKT1657	Stiffener Bracket for	1
6	BRB04411	Steel Cleats 	4
7	CTR21504	Bolts 	8
8	CTR21541	Cam Locks 	8
9	DWL0027	Dowel 1 Inch 	8
10	GLI0191	Insert Nuts for Glides 	4
11	GLI0212	Hex-Base Glides 	4
12	SPC4898	Spacer 	1
13	SCR2507	Screw 5/8 Inch 	12
14	SCR9420	Screw 1 Inch	12
15	SCR9404	Screw 1/2 Inch	8
16	BKT99990	Bracket	4

Warnings

-  Do not over-tighten the screws
- Do not turn cam locks more than 180°

NOTE

 Space Cleats Evenly at top edge of inside face of panel

 Locate Top flush with back and outer edges of End panels. Leave excess overhang to the front.

Assembly should be performed on a clean flat floor.

Verify all items are received before assembling.

Tools

- # 2 Phillips Screwdriver
- 5mm wrench

Integrate Assembly Instructions
Shell Desk with Removable
Access Panel (60" x 30")

(Part No. I60DKSHAP)

STEP 1: ATTACH CLEATS TO THE END PANELS

Place the Left and Right End Panels (Item 2) on a flat surface. Space the 2 Steel Cleats (item 5) evenly on the top edge of inside face of each panel and fasten with the Screws (Item 11) to the End panels. (See Fig. 1)

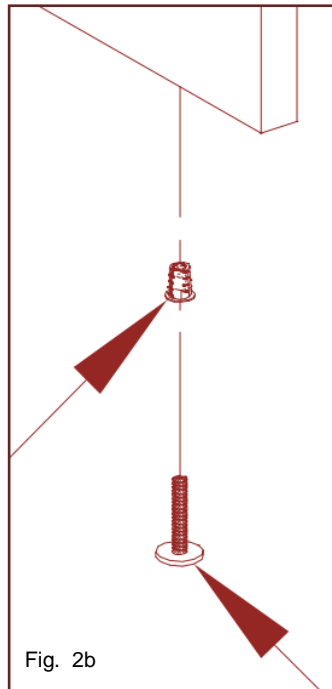
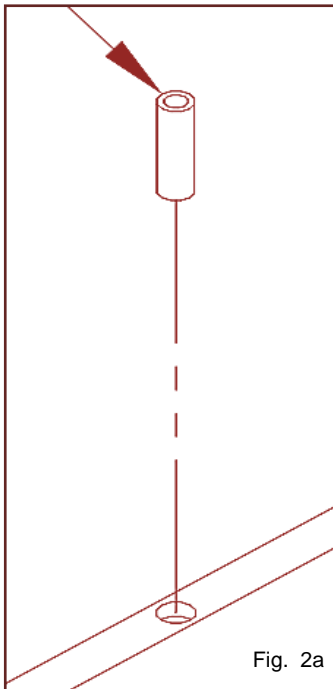
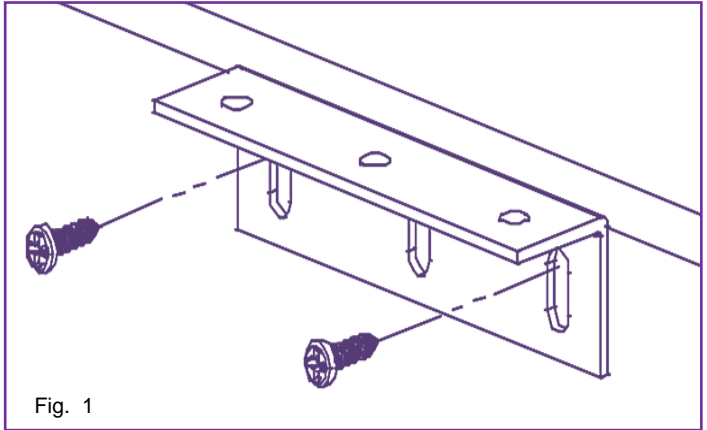

STEP 2: INSERT GLIDES AND SPACER TO PANELS

Insert 2 Glide Nuts (Item 9) each in the holes provided at the bottom edges on the Left and Right End panels and Screw the Hex-Base Glides (Item 10) each in the Glide Nut. (See Figure 2b).

Insert the Spacer (item 12) in the hole provided on the top of the Modesty Back panel (Item 3). (See Figure 2a).

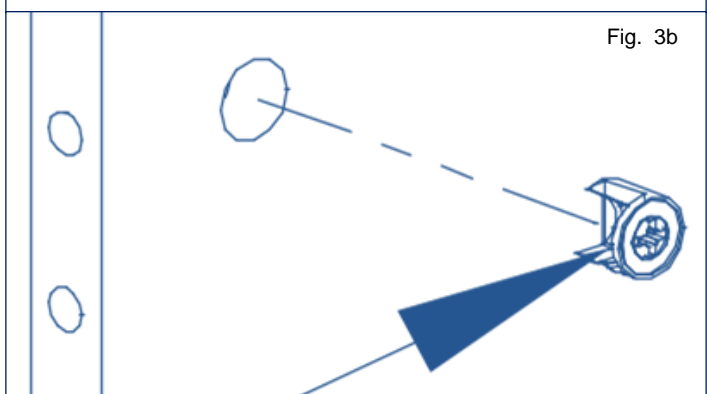
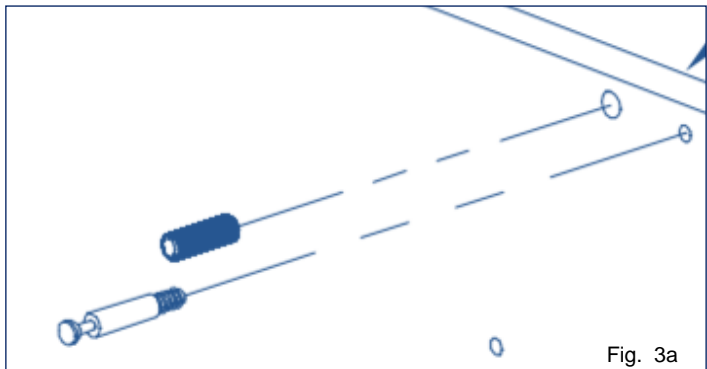

STEP 3: INSERT BOLTS, DOWELS AND CAM-LOCKS TO PANELS

Insert 4 cams (Item 7) each in the holes provided on the Modesty Panel (item 3) (See Fig. 3b). Insert 4 wood dowels (Item 8) and screw 4 Connecting Bolts (Item 6) each in the holes provided on Left and Right End panels (item 2) (See Figure 3a).

Place the Left and Right End panels at right angles on the Modesty Panel so that the Dowels and Bolts are inserted into the pre-drilled holes on the edge of the panels.

Twist-lock all the 8 cams with a Philips screw-driver to the Connecting bolts on the panels.

The Base of the Desk with End panels and Fixed Support Modesty Panels should be assembled with 2 cleats each on the top of the Left and Right End panels.

Integrate Assembly Instructions
Shell Desk with Removable
Access Panel (60" x 30")

(Part No. I60DKSHAP)

Page 3 of 3

STEP 4: ATTACH THE WORKSURFACE

Place the Work Surface (Item 1) on the base assembly so that the pre-installed Stiffener bracket (Item 4) is in the front of the desk

Attach the Work Surface to the base assembly with screws (Item 11) to the 4 steel cleats (previously fastened on the top of Left and Right End panels) (See Figure 4). Locate Top flush with back and outer edges of Left and Right End panel. Leave excess overhang to the front.

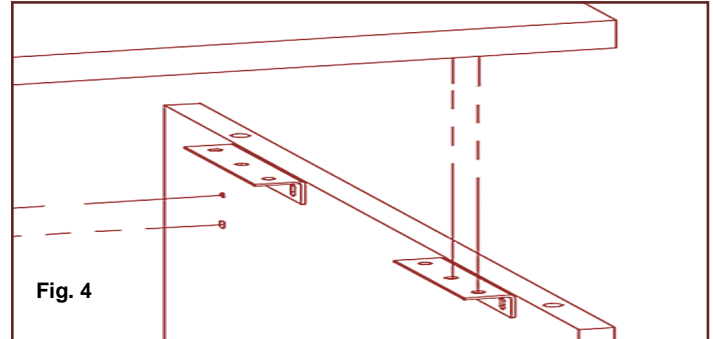

STEP 5: HANG REMOVABLE ACCESS PANEL





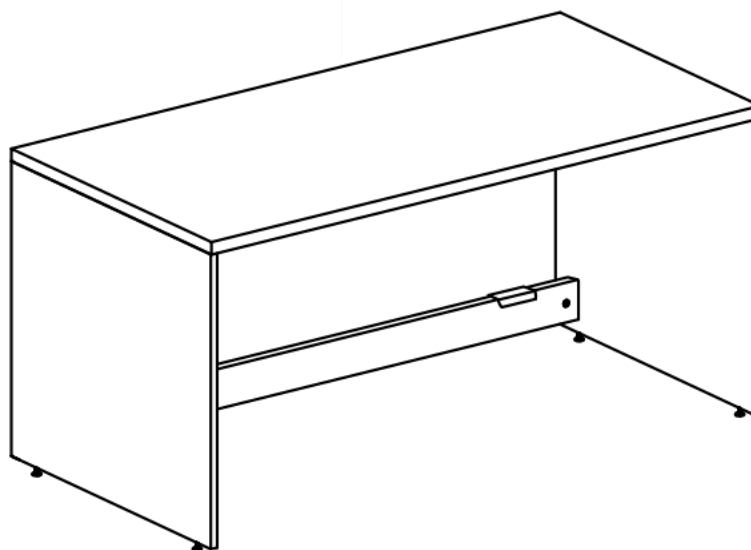

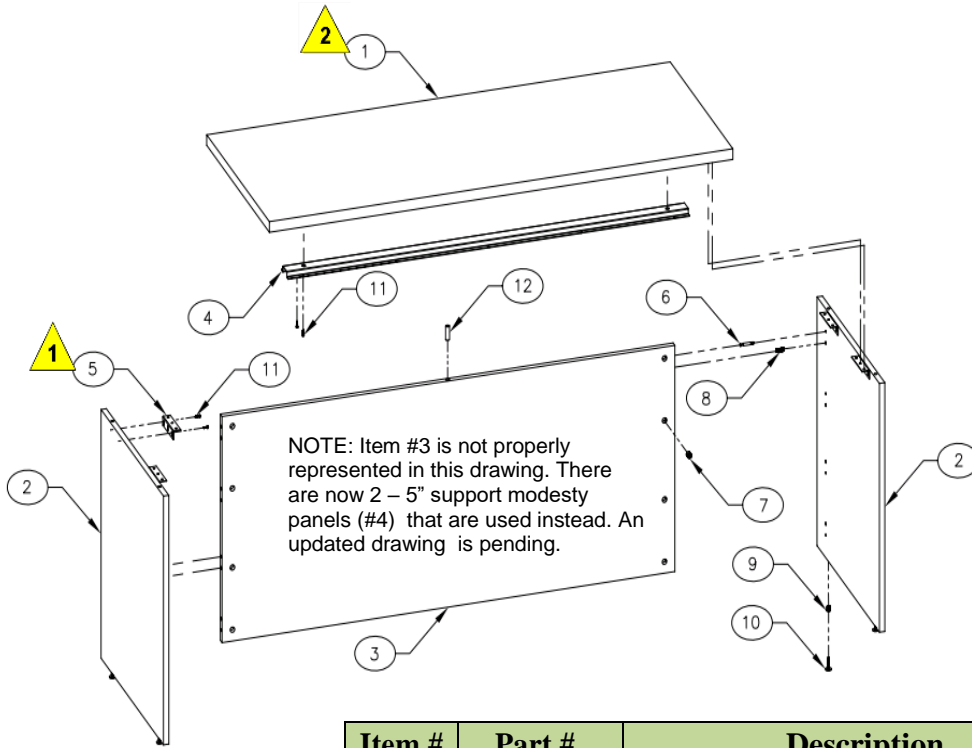

Attach the 2 brackets to both the top and bottom of the Removable Modesty Panel with 1/2" screws in the pre-drilled holes. Hang removable modesty panel on top and bottom of Fixed Support Modesty panels.

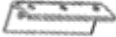
Your Final Assembled Product should look like below





Integrate Assembly Instructions
Shell Desk (72" x 30")
(Part No. I72DKSHAP)





Item #	Part #	Description	Quantity
1	ISA20111	Work Surface 72"	1
2	ISA20015	End Panel Left/Right	2
3	ISA20019	Removable Modesty Panel 72"	1
4		Fixed Support Modesty Panel 5"	2
5	BKT1657	Stiffener Bracket for	1
6	BRB04411	Steel Cleats 	4
7	CTR21504	Bolts 	8
8	CTR21541	Cam Locks 	8
9	DWL0027	Dowel 1 Inch 	8
10	GLI0191	Insert Nuts for Glides 	4
11	GLI0212	Hex-Base Glides 	4
12	SPC4898	Spacer 	1
13	SCR2507	Screw 5/8 Inch 	12
14	SCR9420	Screw 1 Inch	12
15	SCR9404	Screw 1/2 Inch	8
16	BKT99990	Bracket	4

Warnings

-  Do not over-tighten the screws
-  Do not turn cam locks more than 180°

NOTE

 Space Cleats Evenly at top edge of inside face of panel

 Locate Top flush with back and outer edges of End panels. Leave excess overhang to the front.

Assembly should be performed on a clean flat floor.

Verify all items are received before assembling.

Tools

- # 2 Phillips Screwdriver
- 5mm wrench

Integrate Assembly Instructions
Shell Desk (72" x 30")
(Part No. I72DKSHAP)

STEP 1: ATTACH CLEATS TO THE END PANELS

Place the Left and Right End Panels (Item 2) on a flat surface. Space the 2 Steel Cleats (item 5) evenly on the top edge of inside face of each panel and fasten with the Screws (Item 11) to the End panels. (See Fig. 1)

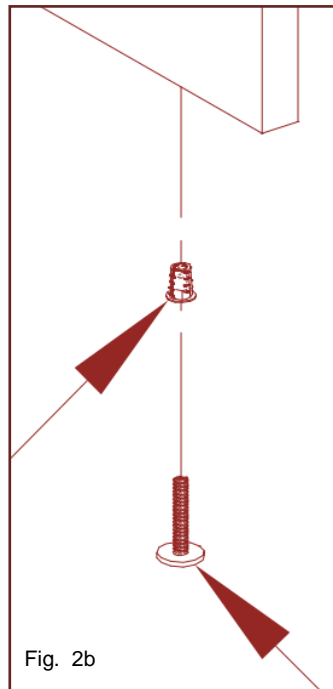
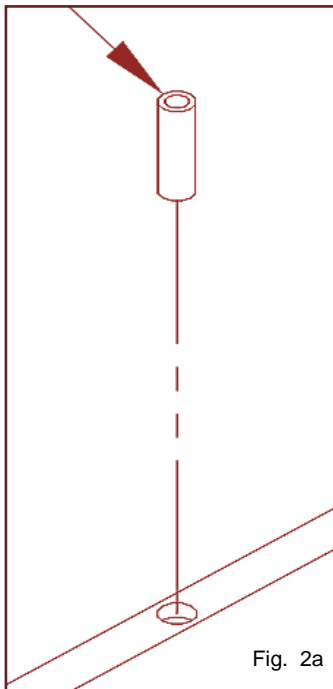
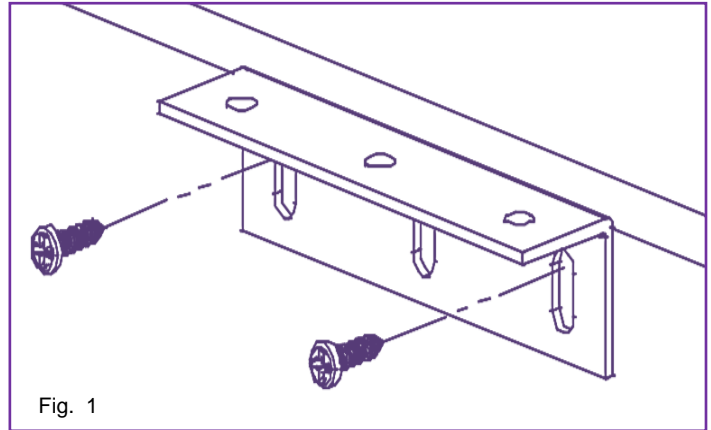

STEP 2: INSERT GLIDES AND SPACER TO PANELS

Insert 2 Glide Nuts (Item 9) each in the holes provided at the bottom edges on the Left and Right End panels and Screw the Hex-Base Glides (Item 10) each in the Glide Nut. (See Figure 2b).

Insert the Spacer (item 12) in the hole provided on the top of the Modesty Back panel (Item 3). (See Figure 2a).

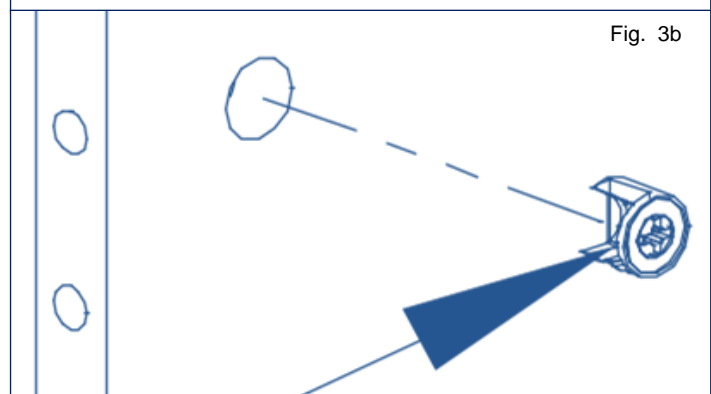
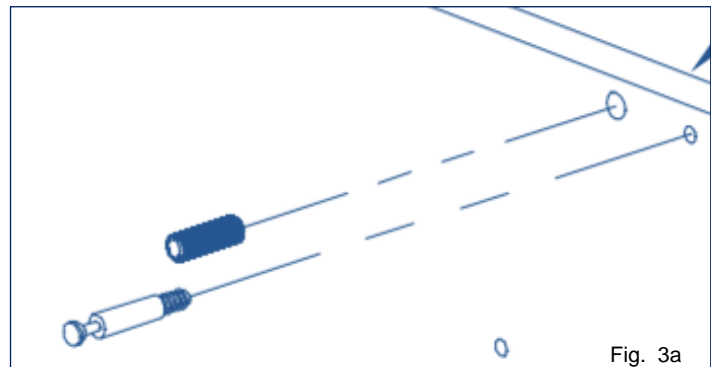

STEP 3: INSERT BOLTS, DOWELS AND CAM-LOCKS TO PANELS

Insert 4 cams (Item 7) each in the holes provided on the Modesty Panel (item 3) (See Fig. 3b). Insert 4 wood dowels (Item 8) and screw 4 Connecting Bolts (Item 6) each in the holes provided on Left and Right End panels (item 2) (See Figure 3a).

Place the Left and Right End panels at right angles on the Modesty Panel so that the Dowels and Bolts are inserted into the pre-drilled holes on the edge of the panels.

Twist-lock all the 8 cams with a Philips screw-driver to the Connecting bolts on the panels.

The Base of the Desk with End panels and Fixed Support Modesty Panels should be assembled with 2 cleats each on the top of the Left and Right End panels.

Integrate Assembly Instructions
Shell Desk with Removable
Access Panel (72" x 30")

(Part No. I72DKSHAP)

Page 3 of 3

STEP 4: ATTACH THE WORKSURFACE

Place the Work Surface (Item 1) on the base assembly so that the pre-installed Stiffener bracket (Item 4) is in the front of the desk

Attach the Work Surface to the base assembly with screws (Item 11) to the 4 steel cleats (previously fastened on the top of Left and Right End panels) (See Figure 4). Locate Top flush with back and outer edges of Left and Right End panel. Leave excess overhang to the front.

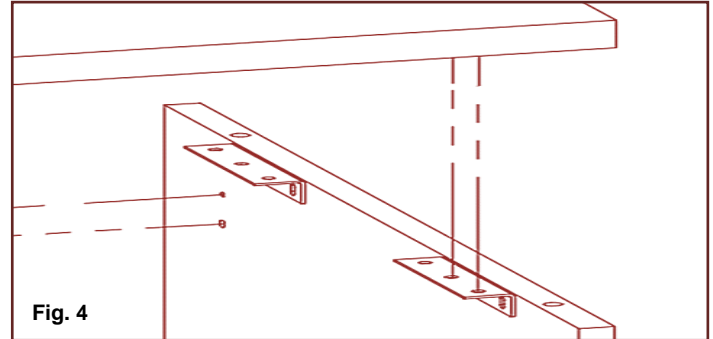
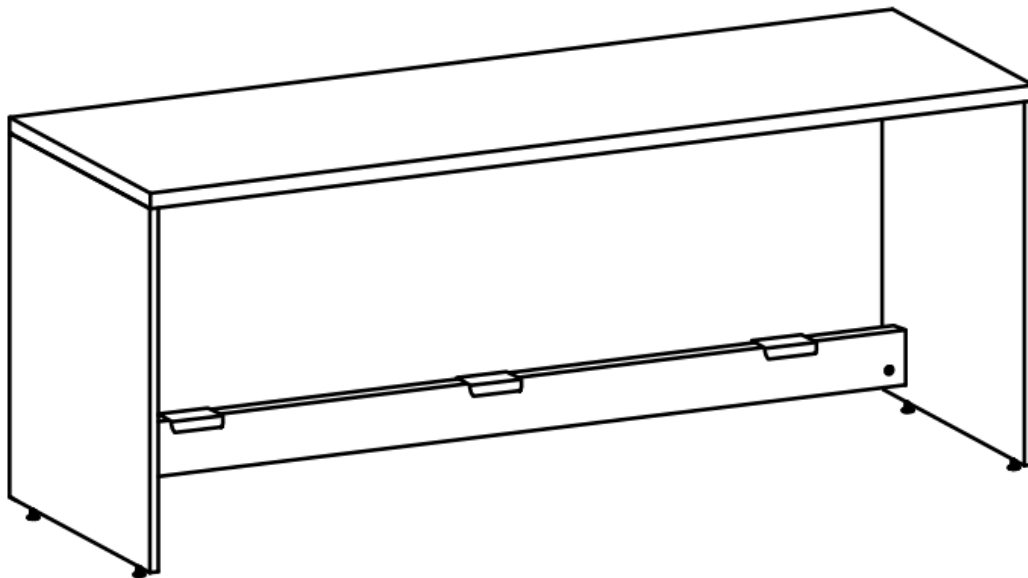

Fig. 4

STEP 5: HANG REMOVABLE ACCESS PANEL

Attach the 2 brackets to both the top and bottom of the Removable Modesty Panel with 1/2" screws in the pre-drilled holes. Hang removable modesty panel on top and bottom of Fixed Support Modesty panels.

Your Final Assembled Product should look like below



Integrate Assembly Instructions
Double Pedestal Desk (60")

(Part No. I60DKDP)

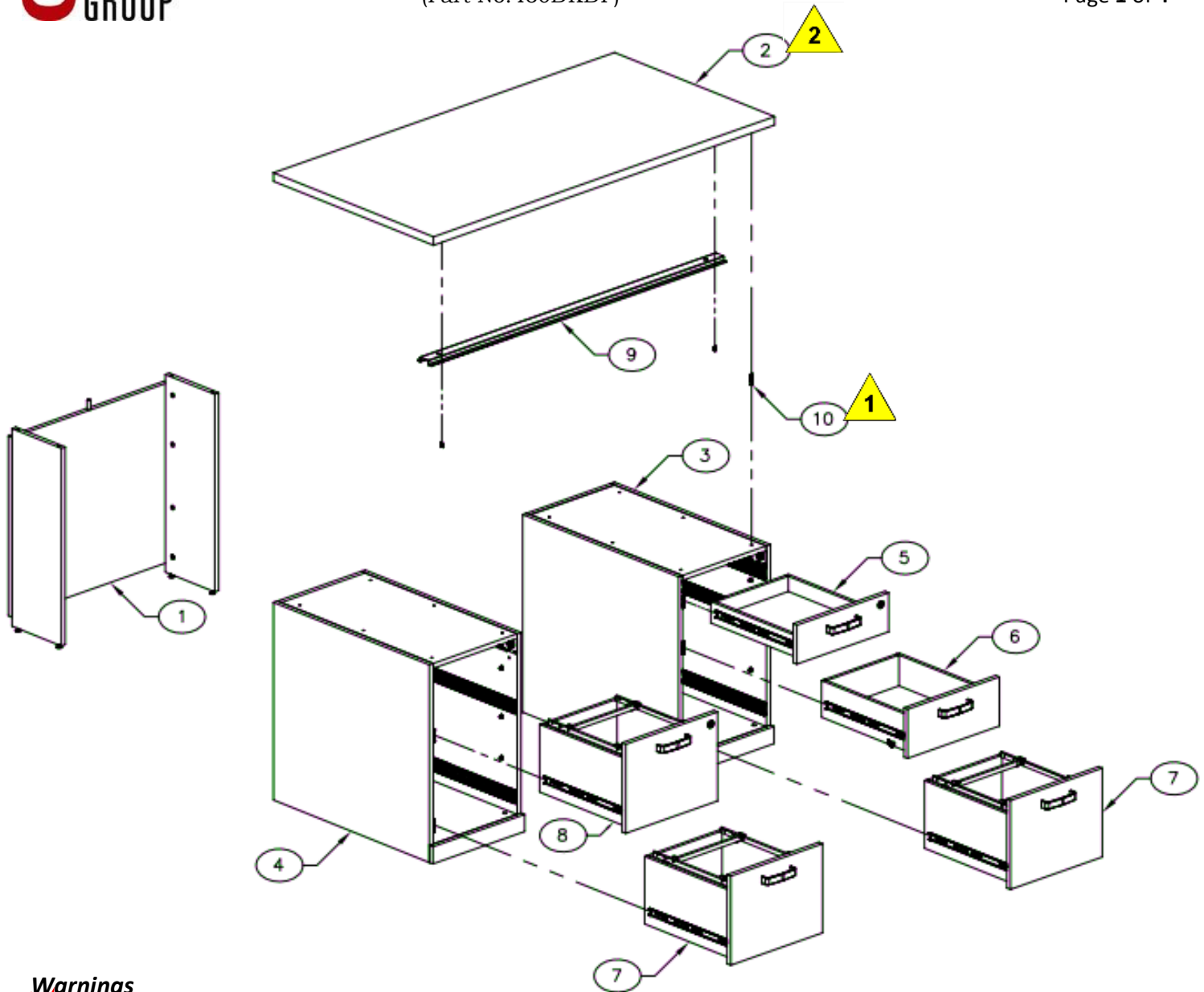

Warnings

- Do not over-tighten the screws.
- Do not turn cam-locks more than 180°.

Note

- Attach top to Pedestal with #SCR0680 screws thru holes in Pedestal interior top
- Locate Top flush with back and outer edges of Pedestal End panels. Leave excess overhang to the front.
 - Assembly should be performed on a clean flat floor.
 - Verify all items are received before assembling.

Tools

- # 2 Phillips Screwdriver
- 5mm wrench

Item #	Part #	Description	Quantity
1	ISA10137	Modesty Panel Assembly	1
2	ISA10035	WorkSurface	1
3	ISA50017	Right Pedestal Subassembly (PDF as shown)	1
4	ISA50021	Left Pedestal Subassembly (FF as shown)	1
5	ISA130001	Pencil Drawer with Lock Subassembly	1
6	ISA130005	Drawer Subassembly	1
7	ISA130015	File Drawer Subassembly	2
8	ISA130019	File Drawer with Lock Subassembly	1
9	BKT1657	Stiffner Bracket (comes pre-installed)	1
10	SCR0680	Screw 1-5/8 Inch	12

Integrate Assembly Instructions
Double Pedestal Desk (60")

(Part No. I60DKDP)

STEP 1: ASSEMBLE THE MODESTY PANEL

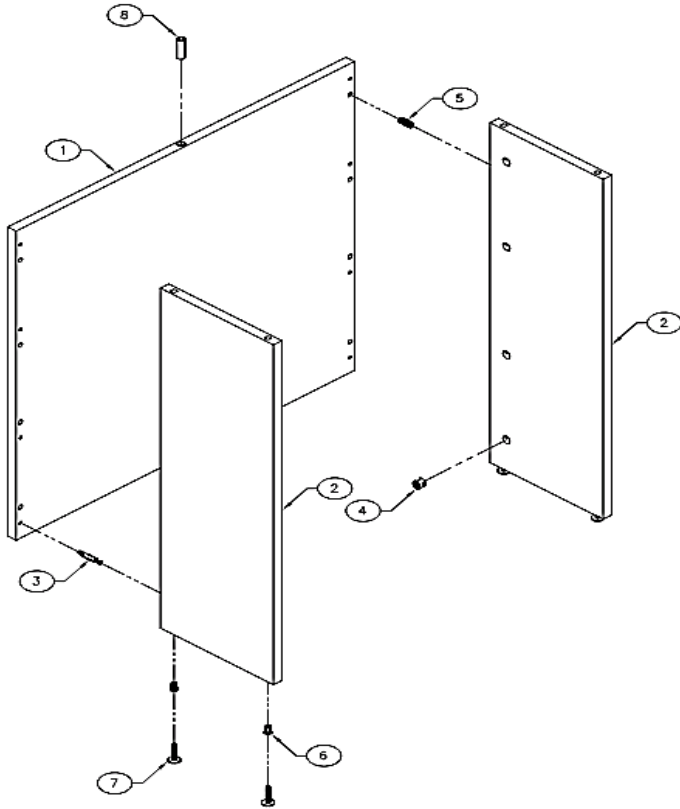

Item #	Part #	Description	Quantity
M1	ISA10143	Modesty Panel Back	1
M2	ISA10145	Modesty Panel End (Left/Right)	2
M3	CTR21504	Bolts	8
M4	CTR21541	Cam Locks	8
M5	DWL0027	Dowel 1 Inch	8
M6	GLI0191	Insert Nuts for Glides	4
M7	GLI0212	Hex-Base Glides	4
M8	SPC4898	Spacer	1

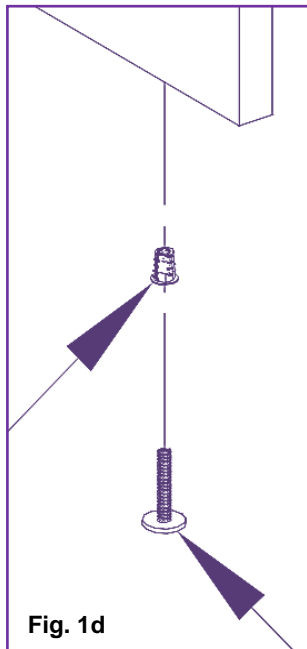
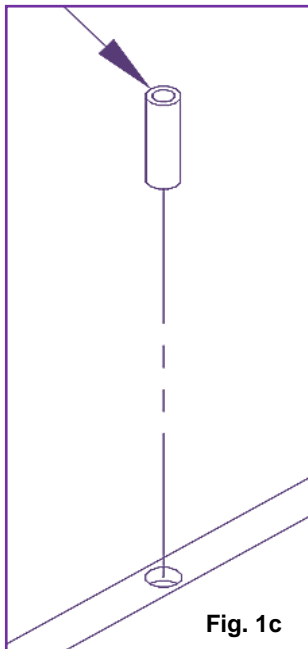
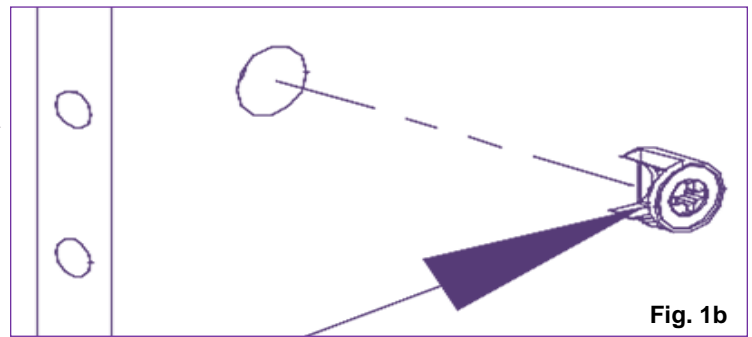
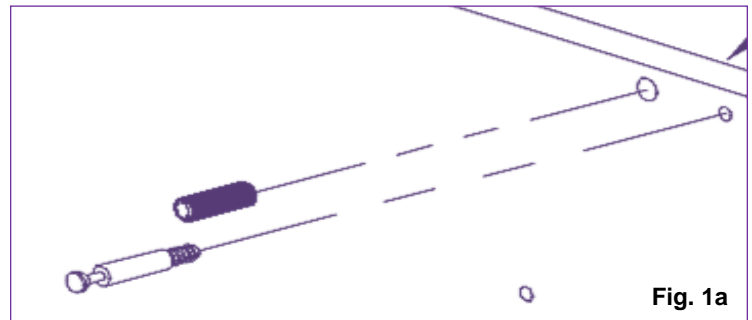

Place the Modesty Back Panel (Item M1) on a flat surface. Insert 8 wood dowels (Item M5) and screw 6 Connecting Bolts (Item M3) each in the holes provided on Back panel. (See Figure 1a).

Insert 4 cams (Item M4) each in the holes provided on both left and right Modesty End Panels (item M2). (See Figure 1b). Insert 2 Glide Nuts (Item M6) each on the End panels and Screw two Hex-Base Glides (Item M7) each in the Glide Nut. (See Figure 1d). Insert the Spacer (item M8) in the hole provided on the top of the Modesty Back panel. (See Figure 1c).

Place the Back panel at right angles to the Left and Right End panels so that the Dowels and Bolts are inserted into the pre-drilled holes on the edge of the panels. Twist-lock all the 8 cams with a Phillips screw-driver to the Connecting bolts on the end panels.

STEP 2: ATTACH THE WORKSURFACE TO PEDESTALS

Place the Worksurface (Item 2) on the Right Pedestal Assembly (Item 3) and Left Pedestal Assembly (item 4) so that the Stiffener bracket (Item 9) is in the front of the desk

Attach top to both Left and Right Pedestal with 6 screws (Item 10) each thru holes in Pedestal interior top. (See Figure 2). Locate Top flush with back and outer edges of Pedestal End panels. Leave excess overhang to the front.

Place the Modesty Panel assembly (flushed or recessed) to the back edge of the Worksurface.

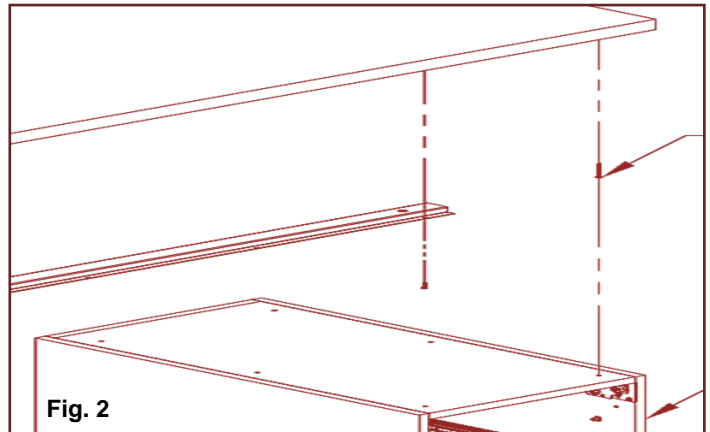

Fig. 2

STEP 3: : INSERT DRAWERS IN THE ASSEMBLED PRODUCT

Locate the Glides as shown in Figure 3a above on the Drawer Assembly (Items 5, 6, 7, and 8). Locate the Glide-Insert as shown in Figure 3b inside the Pedestal Assembly (items 3 and 4 of the currently assembled product).

Carefully, insert the Drawers by placing the glide on the rollers of the glide-insert in the Pedestal as shown in Figure 3c. In case of File/File Configuration, the File drawer assembly with lock should be inserted on the top and the drawer without the lock should be inserted at the bottom. In case of Pencil/Drawer/File configuration, place the pencil drawer on the top, Drawer in middle, and File Drawer in the bottom.

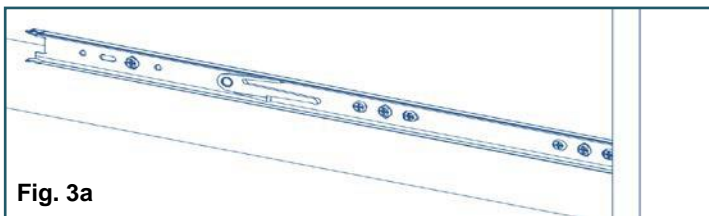

Fig. 3a



Fig. 3b

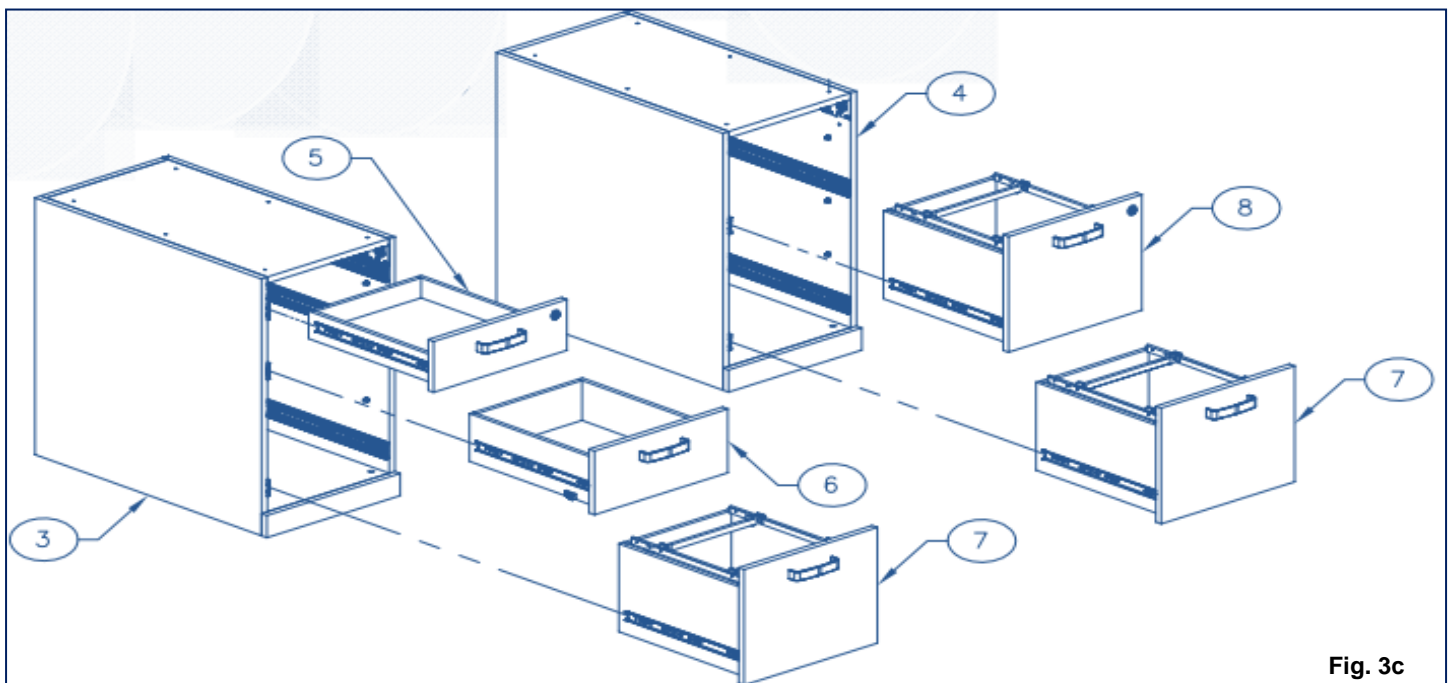
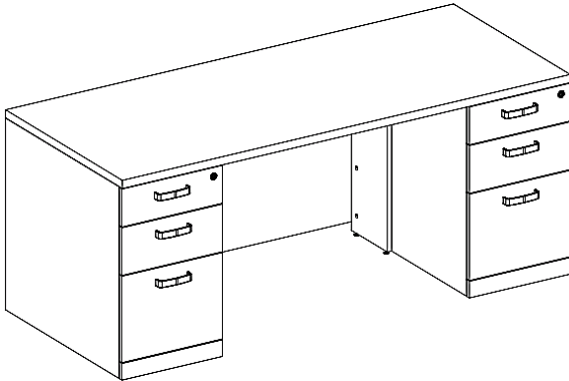

Fig. 3c

Integrate Assembly Instructions
Double Pedestal Desk (60")
(Part No. I60DKDP)

Your Final Assembled Product should look like below (Based on the Ordered Configuration)



Left and Right Pedestal Pencil/Drawer/File Configuration

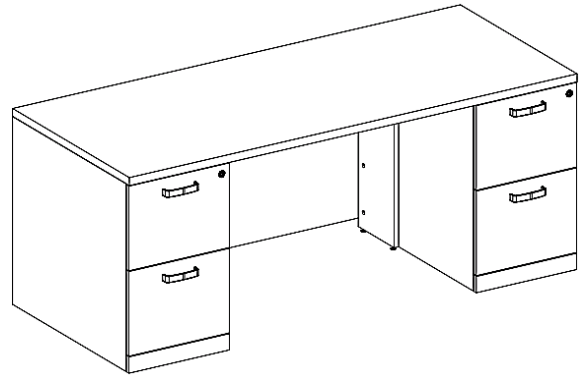

Left and Right Pedestal File/File Configuration

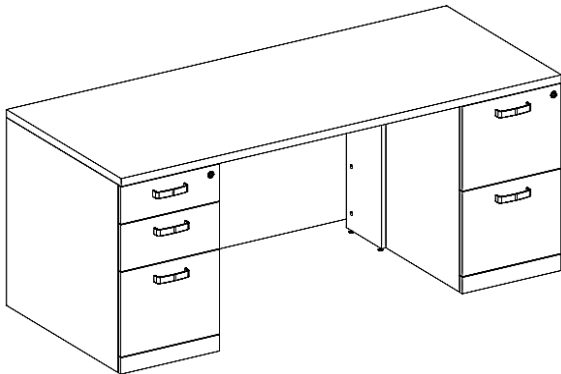

Left Pedestal: Pencil/Drawer/File and Right Pedestal: File/File Configuration

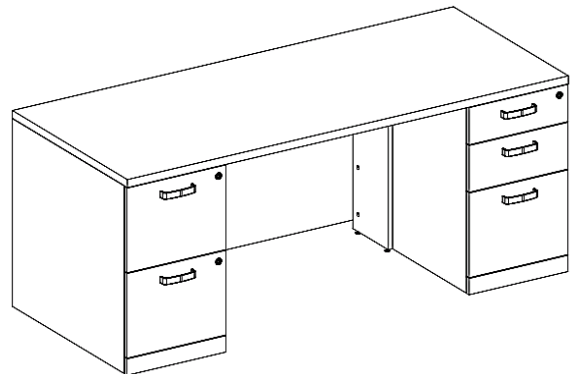

Left Pedestal: File/File and Right Pedestal: Pencil/Drawer/File Configuration

**Integrate Assembly Instructions
Double Pedestal Desk (72")**

(Part No. I72DKDP)

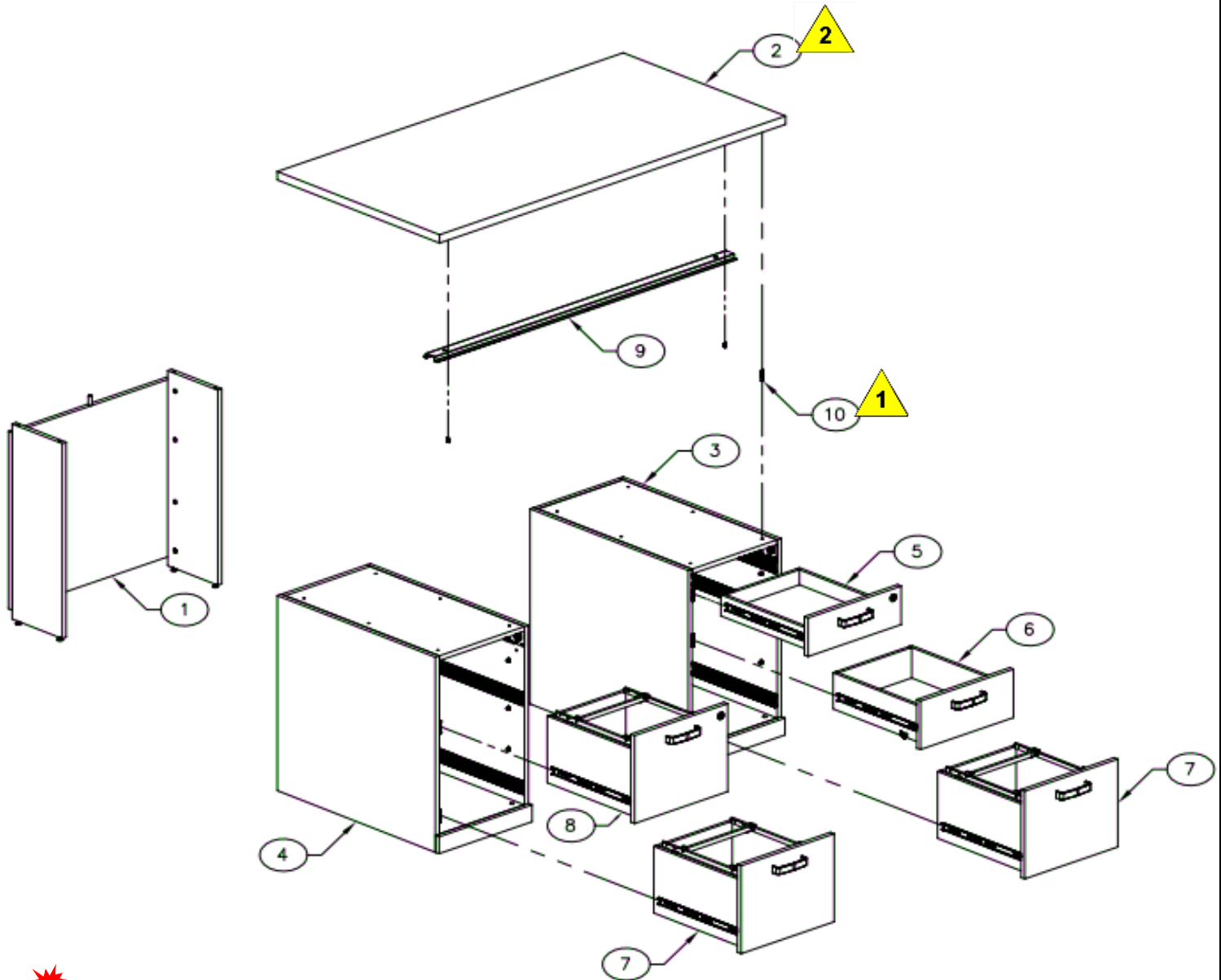

Do not turn cam-locks more than 180°.

Note

1 Attach top to Pedestal with #SCR0680 screws thru holes in Pedestal interior top

2 Locate Top flush with back and outer edges of Pedestal End panels. Leave excess overhang to the front.

Assembly should be performed on a clean flat floor.

Verify all items are received before assembling.

Tools

#2 Phillips Screwdriver

5mm wrench





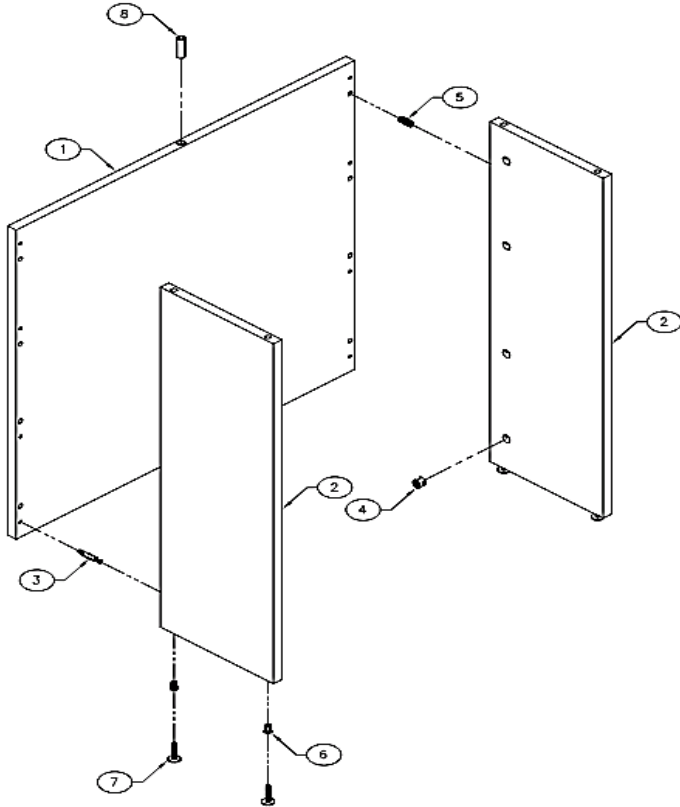

Item #	Part #	Description	Quantity
1	ISA10133	Modesty Panel Assembly	1
2	ISA10033	WorkSurface	1
3	ISA50017	Right Pedestal Subassembly (PDF as shown)	1
4	ISA50021	Left Pedestal Subassembly (FF as shown)	1
5	ISA130001	Pencil Drawer with Lock Subassembly	1
6	ISA130005	Drawer Subassmebly	1
7	ISA130015	File Drawer Subassembly	2
8	ISA130019	File Drawer with Lock Subassembly	1
9	BKT1657	Stiffner Bracket (comes pre-installed)	1
10	SCR0680	Screw 1-5/8 Inch 	12

Integrate Assembly Instructions
Double Pedestal Desk (72")

(Part No. I72DKDP)

STEP 1: ASSEMBLE THE MODESTY PANEL



Item #	Part #	Description	Quantity
M1	ISA10141	Modesty Panel Back	1
M2	ISA10145	Modesty Panel End (Left/Right)	2
M3	CTR21504	Bolts 	8
M4	CTR21541	Cam Locks 	8
M5	DWL0027	Dowel 1 Inch 	8
M6	GLI0191	Insert Nuts for Glides 	4
M7	GLI0212	Hex-Base Glides 	4
M8	SPC4898	Spacer 	1

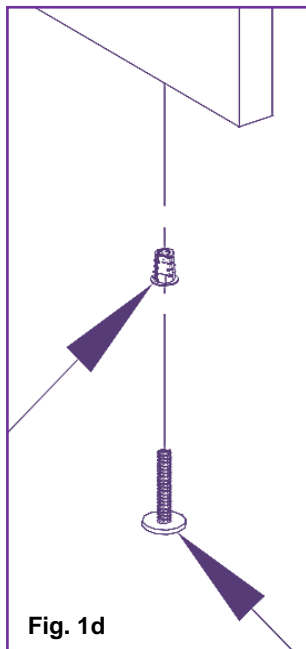
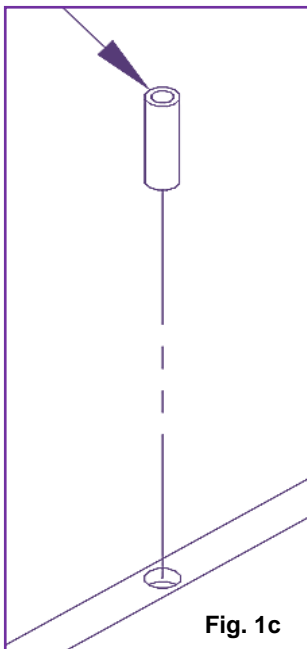
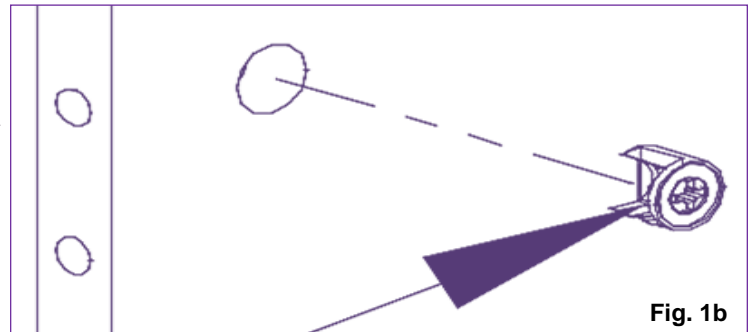
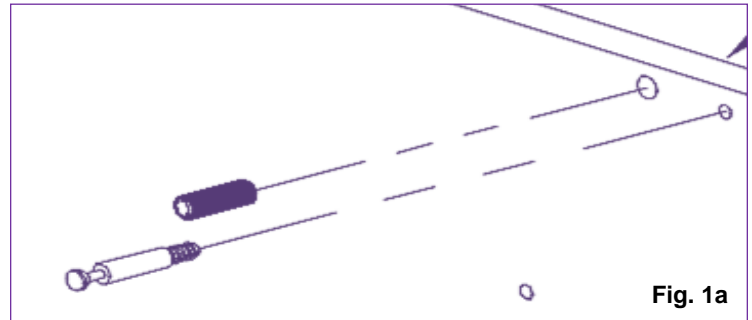

Place the Modesty Back Panel (Item M1) on a flat surface. Insert 8 wood dowels (Item M5) and screw 6 Connecting Bolts (Item M3) each in the holes provided on Back panel. (See Figure 1a).

Insert 4 cams (Item M4) each in the holes provided on both left and right Modesty End Panels (item M2). (See Figure 1b). Insert 2 Glide Nuts (Item M6) each on the End panels and Screw two Hex-Base Glides (Item M7) each in the Glide Nut. (See Figure 1d). Insert the Spacer (item M8) in the hole provided on the top of the Modesty Back panel. (See Figure 1c).

Place the Back panel at right angles to the Left and Right End panels so that the Dowels and Bolts are inserted into the pre-drilled holes on the edge of the panels. Twist-lock all the 8 cams with a Philips screw-driver to the Connecting bolts on the end panels.

Integrate Assembly Instructions
Double Pedestal Desk (72")

(Part No. I72DKDP)

STEP 2: ATTACH THE WORKSURFACE TO PEDESTALS

Place the Worksurface (Item 2) on the Right Pedestal Assembly (Item 3) and Left Pedestal Assembly (item 4) so that the Stiffener bracket (Item 9) is in the front of the desk

Attach top to both Left and Right Pedestal with 6 screws (Item 10) each thru holes in Pedestal interior top. (See Figure 2). Locate Top flush with back and outer edges of Pedestal End panels. Leave excess overhang to the front.

Place the Modesty Panel assembly (flushed or recessed) to the back edge of the Worksurface.

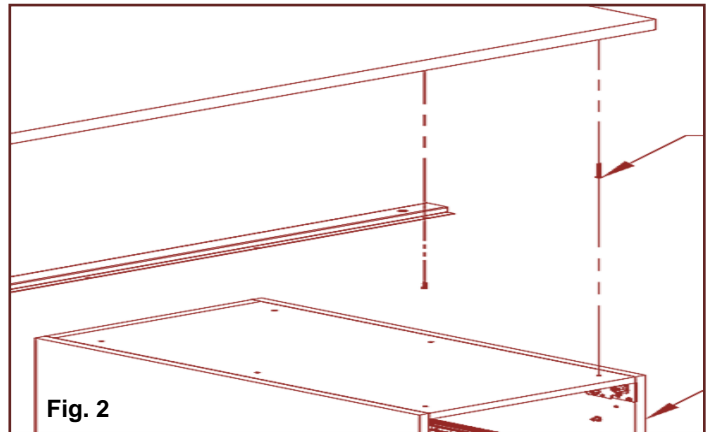

Fig. 2

STEP 3: : INSERT DRAWERS IN THE ASSEMBLED PRODUCT

Locate the Glides as shown in Figure 3a above on the Drawer Assembly (Items 5, 6, 7, and 8). Locate the Glide-Insert as shown in Figure 3b inside the Pedestal Assembly (items 3 and 4 of the currently assembled product).

Carefully, insert the Drawers by placing the glide on the rollers of the glide-insert in the Pedestal as shown in Figure 3c. In case of File/File Configuration, the File drawer assembly with lock should be inserted on the top and the drawer without the lock should be inserted at the bottom. In case of Pencil/Drawer/File configuration, place the pencil drawer on the top, Drawer in middle, and File Drawer in the bottom.

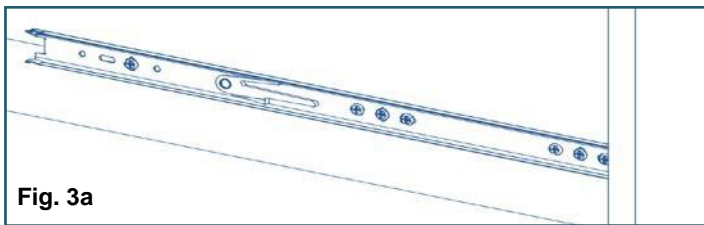

Fig. 3a

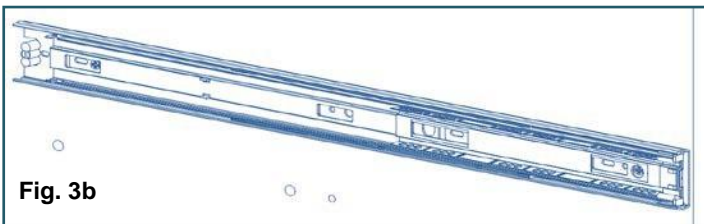

Fig. 3b

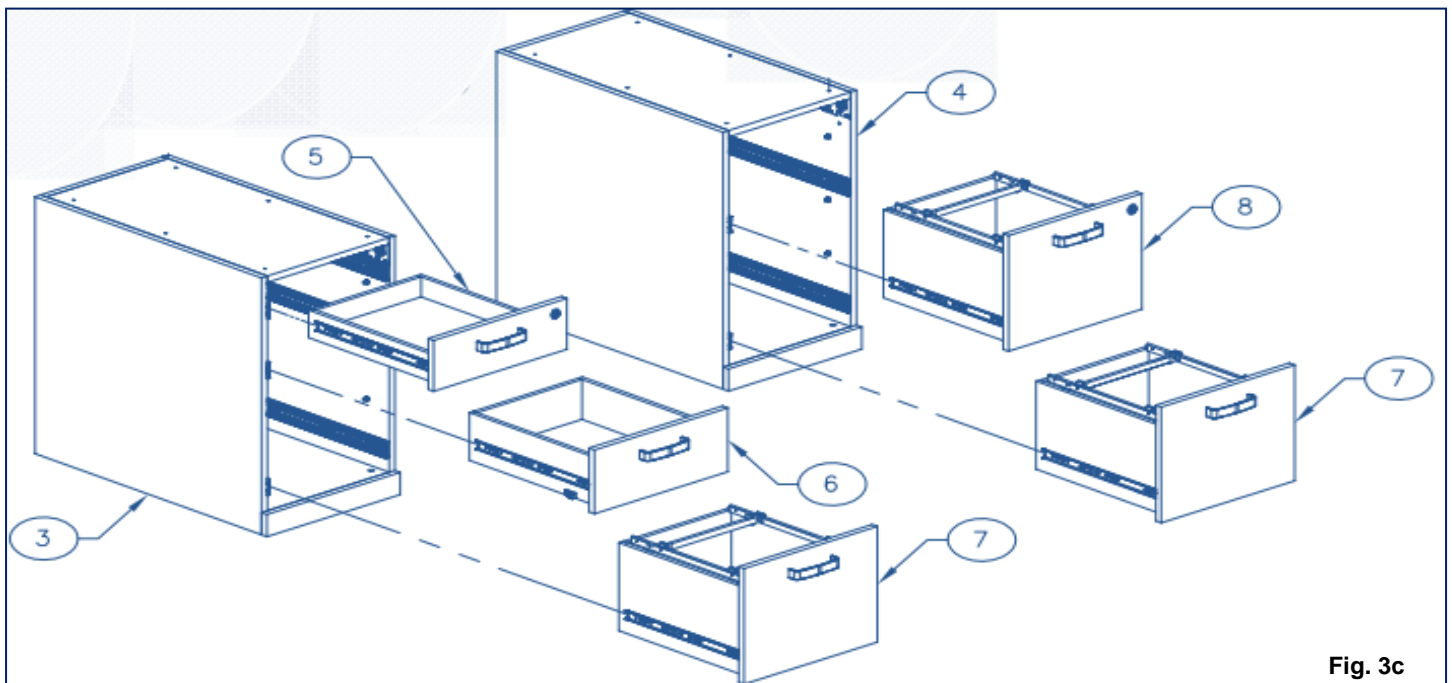
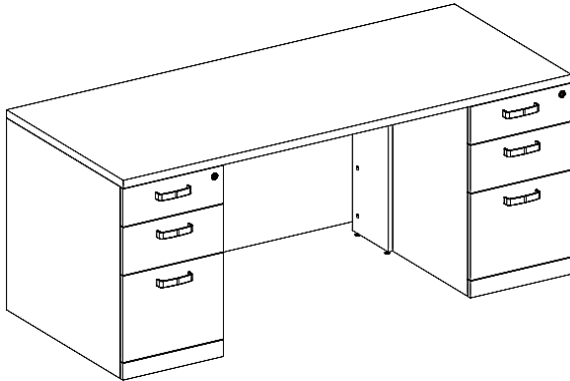

Fig. 3c

Integrate Assembly Instructions
Double Pedestal Desk (72")
(Part No. I72DKDP)

Your Final Assembled Product should look like below (Based on the Ordered Configuration)



Left and Right Pedestal Pencil/Drawer/File Configuration

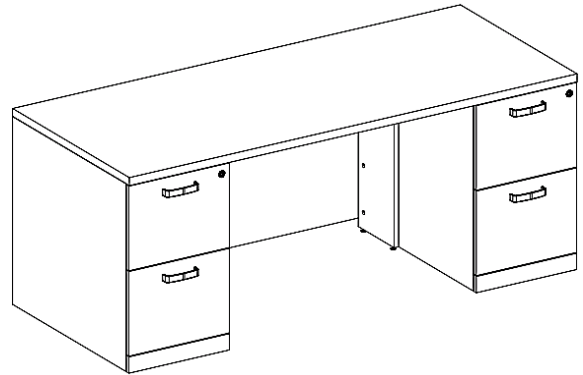

Left and Right Pedestal File/File Configuration

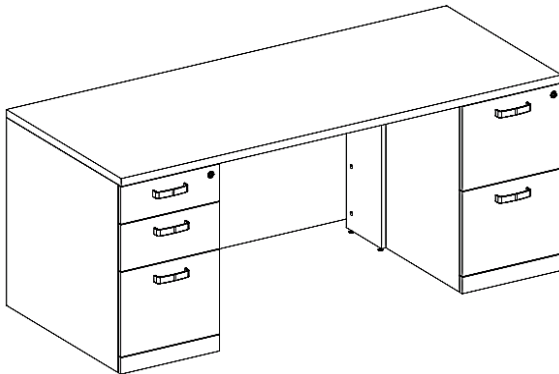

Left Pedestal: Pencil/Drawer/File and Right Pedestal: File/File Configuration

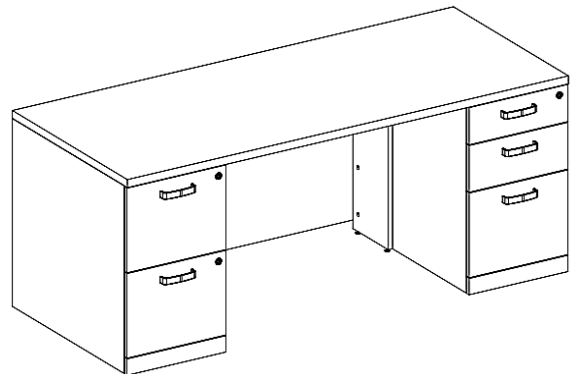

Left Pedestal: File/File and Right Pedestal: Pencil/Drawer/File Configuration

Integrate Disassembly Instructions
Shell Desk (60" x 30")
 (Part No. I60DKSH)

General Notes:

1. Disassembly time: 20-30 Minutes
2. This procedure assumes basic familiarity with hand tools and furniture terminology. No specialized training is required.
3. All materials removed and disassembled can be sorted and segregated with like materials and disposed of or recycled according to recycling availability or waste acceptance.
4. To find a recycling facility in your region, please visit <http://www.recyclingmarkets.net>

Material Type: ■ A. Steel ■ B. Laminated Particle Board ■ C. Plastic

Procedure:

- 1a. Remove all Drawers and Suspension Glides.
- 1b. Remove Dividers and Pencil Trays (if included).
- 2a. Remove plastic Ramps from Drawers.
- 2b. Remove screws holding plastic Support Blocks from cabinet.
- 2c. Remove plastic Rods and Spring Retainers from cabinet..
3. Remove Lock Clip and remove Lock.
4. Remove plastic Wheels or Adjustable Glides.

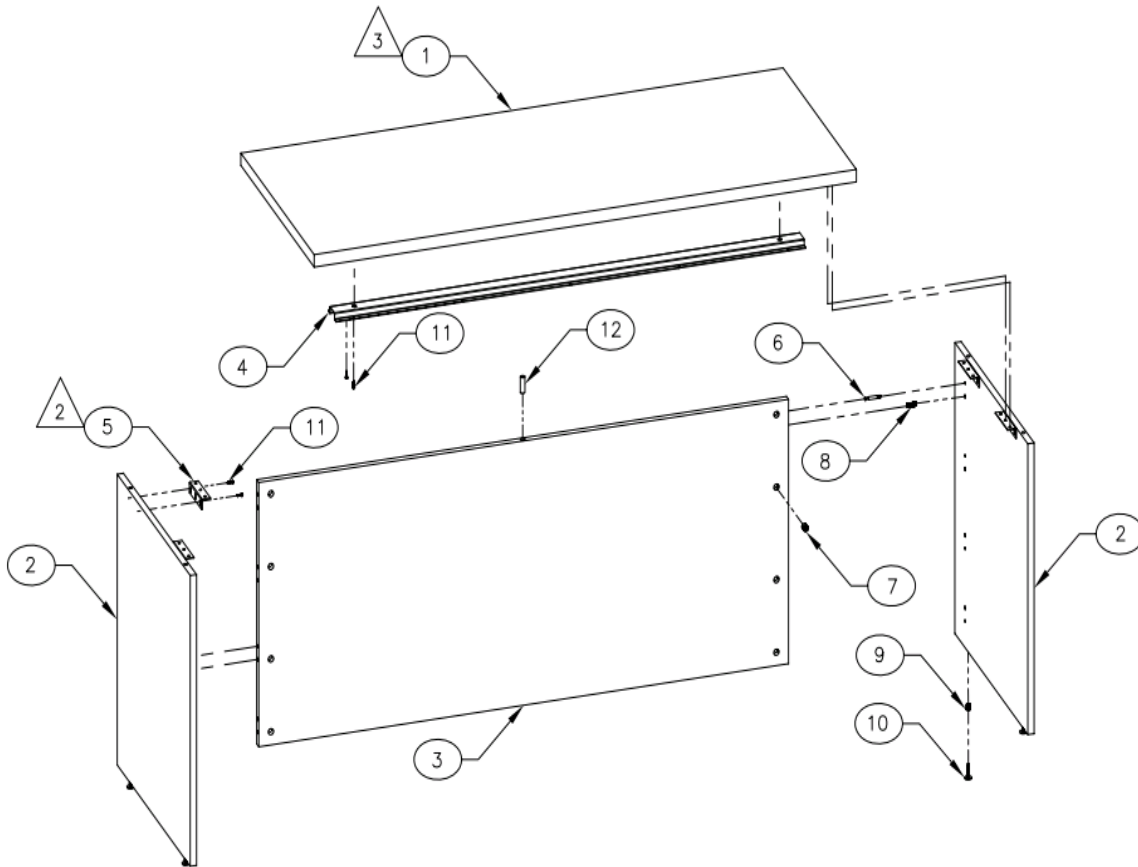



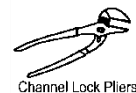
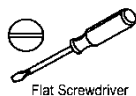



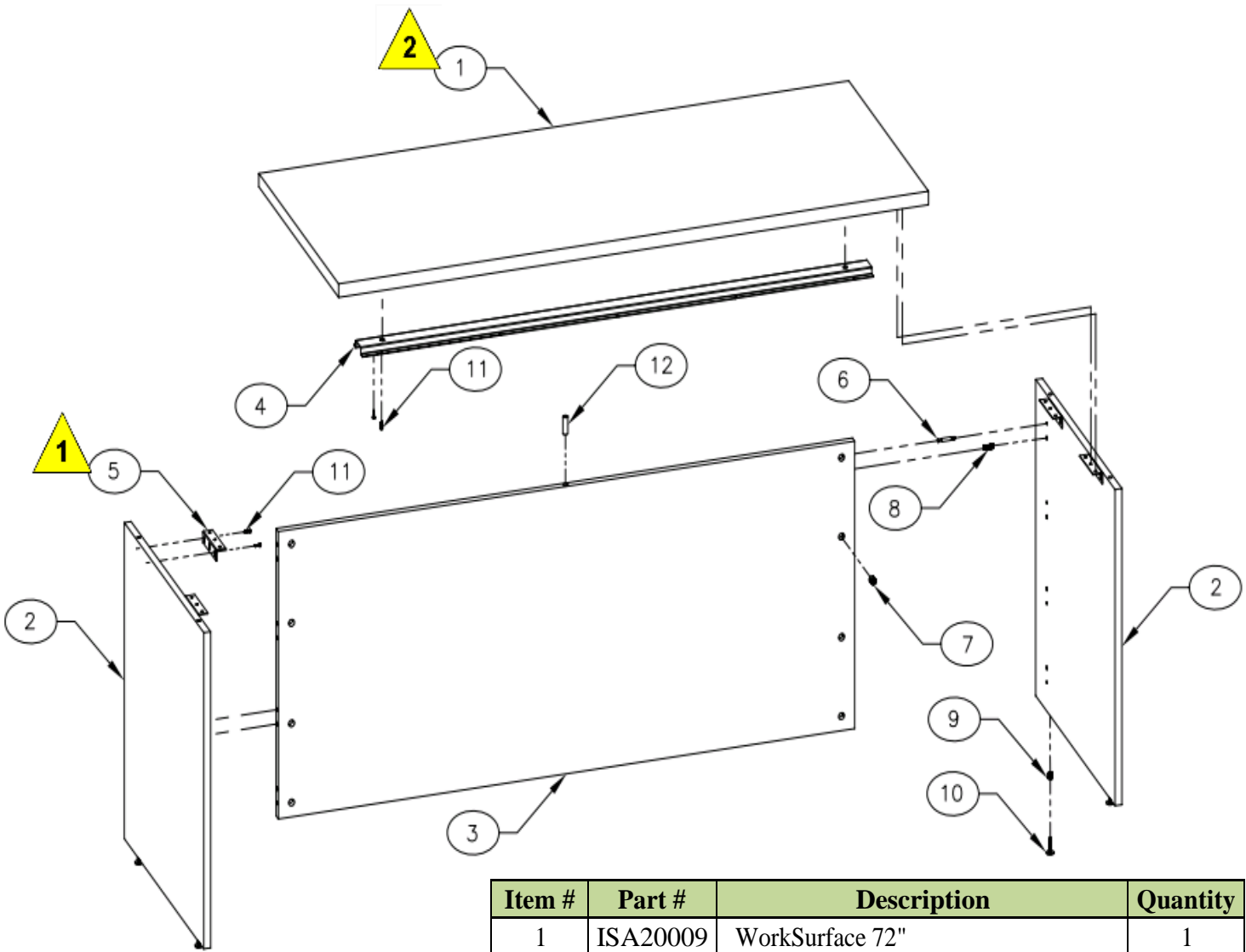

Required Tools





Integrate Assembly Instructions
Shell Desk (72" x 30")
(Part No. I72DKSH)





Item #	Part #	Description	Quantity
1	ISA20009	WorkSurface 72"	1
2	ISA20013	End Panel Left/Right	2
3	ISA20017	Modesty Panel 72"	1
4	BKT1657	Stiffner Bracket for WorkSurface	1
5	BRB0441	Steel Cleats 	4
6	CTR21504	Bolts 	8
7	CTR21541	Cam Locks 	8
8	DWL0027	Dowel 1 Inch 	8
9	GLI0191	Insert Nuts for Glides 	4
10	GLI0212	Hex-Base Glides 	4
11	SCR2507	Screw 5/8 Inch 	24
12	SPC4898	Spacer 	1

Warnings

-  Do not over-tighten the screws.
-  Do not turn cam-locks more than 180°.

Note

-  Space Cleats Evenly at top edge of inside face of panel
-  Locate Top flush with back and outer edges of End panels. Leave excess overhang to the front.
- Assembly should be performed on a clean flat floor.
- Verify all items are received before assembling.

Tools

- #2 Phillips Screwdriver
- 5mm wrench

STEP 1: ATTACH CLEATS TO THE END PANELS

Place the Left and Right End Panels (Item 2) on a flat surface. Space the 2 Steel Cleats (item 5) evenly on the top edge of inside face of each panel and fasten with the Screws (Item 11) to the End panels. (See Fig. 1)

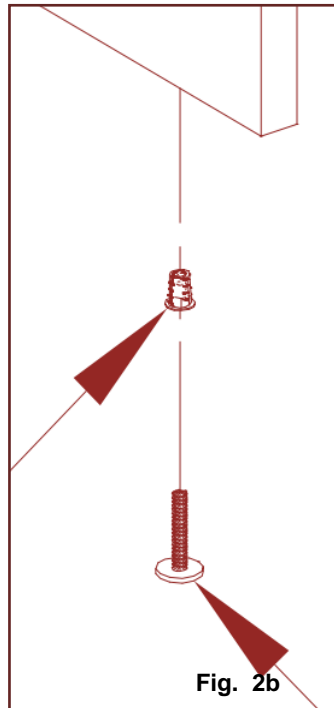
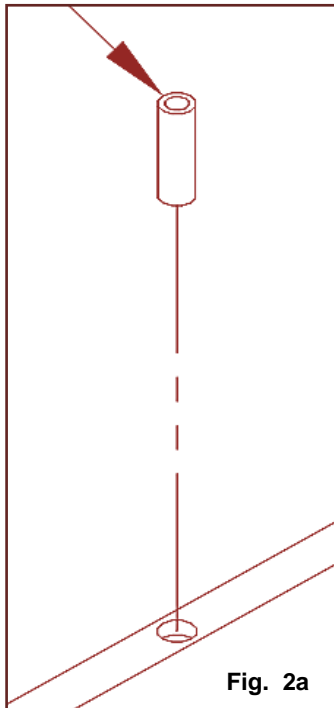
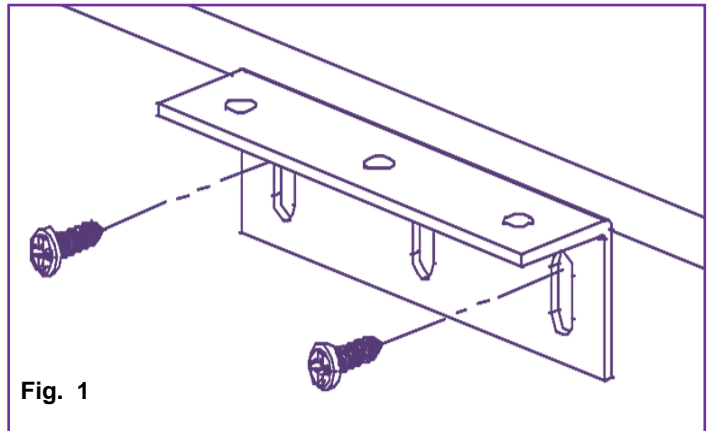

STEP 2: INSERT GLIDES AND SPACER TO PANELS

Insert 2 Glide Nuts (Item 9) each in the holes provided at the bottom edges on the Left and Right End panels and Screw the Hex-Base Glides (Item 10) each in the Glide Nut. (See Figure 2b).

Insert the Spacer (item 12) in the hole provided on the top of the Modesty Back panel (Item 3). (See Figure 2a).

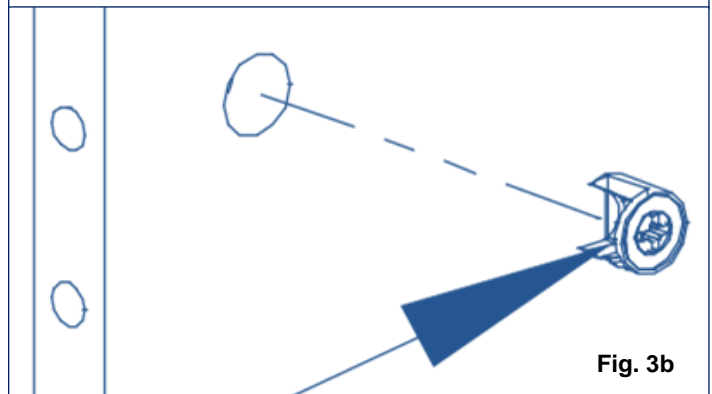
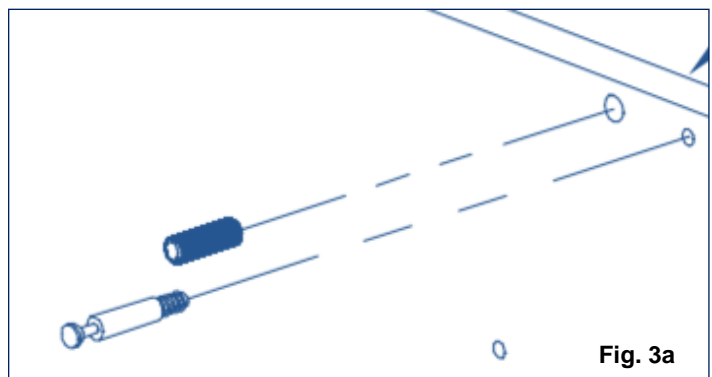

STEP 3: INSERT BOLTS, DOWELS AND CAM-LOCKS TO PANELS

Insert 4 cams (Item 7) each in the holes provided on the Modesty Panel (item 3) (See Fig. 3b). Insert 4 wood dowels (Item 8) and screw 4 Connecting Bolts (Item 6) each in the holes provided on Left and Right End panels (item 2) (See Figure 3a).

Place the Left and Right End panels at right angles on the Modesty Panel so that the Dowels and Bolts are inserted into the pre-drilled holes on the edge of the panels.

Twist-lock all the 8 cams with a Philips screw-driver to the Connecting bolts on the panels.

Your Base of the Desk with End panels and Modesty Panel should be assembled with 2 cleats each on the top of the Left and Right End panels.

STEP 4: ATTACH THE WORKSURFACE

Place the Worksurface (Item 1) on the base assembly so that the pre-installed Stiffener bracket (Item 4) is in the front of the desk

Attach the Worksurface to the base assembly with screws (Item 11) to the 4 steel cleats (previously fastened on the top of Left and Right End panels) (See Figure 4). Locate Top flush with back and outer edges of Left and Right End panel. Leave excess overhang to the front.

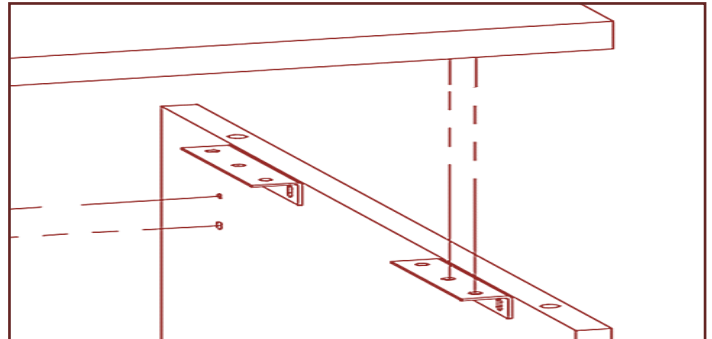

Your Final Assembled Product should look like below

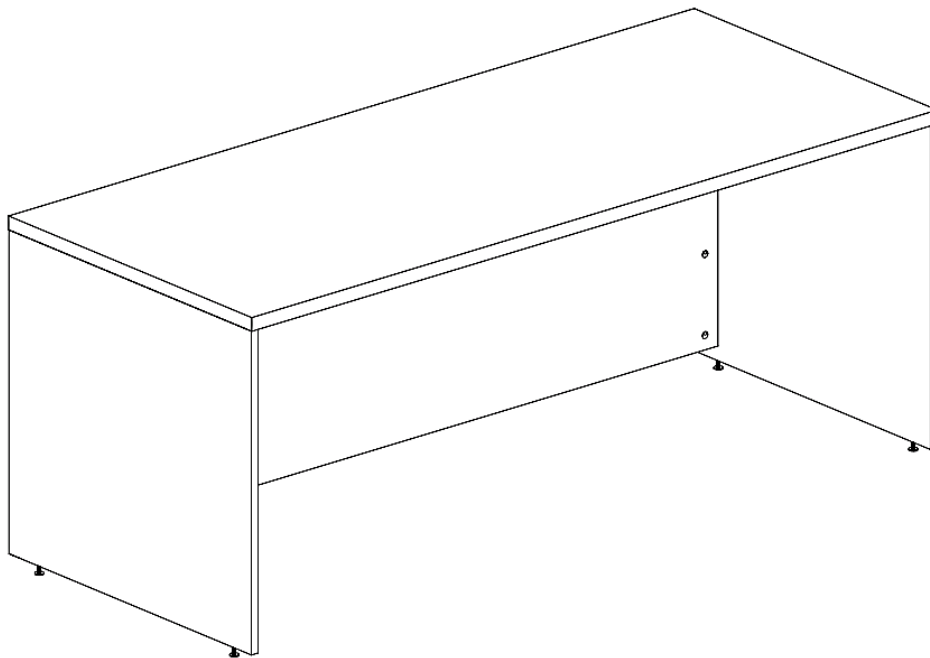

Integrate Assembly Instructions
Single Pedestal Desk (60") (File/File)
(Part No. I60DKSP)

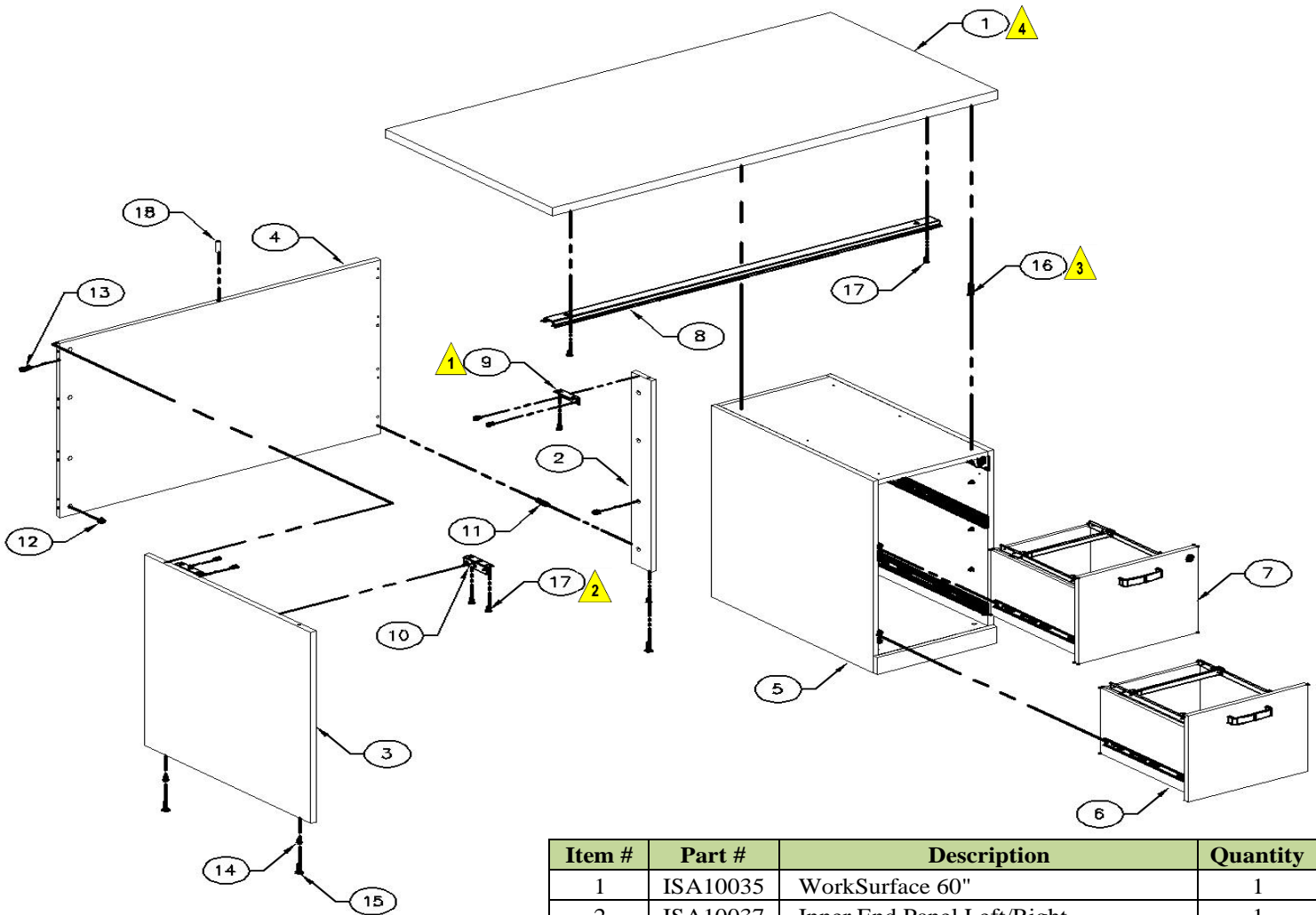

Warnings

- Do not over-tighten the screws.
- Do not turn cam-locks more than 180°.

Note

- 1 Locate Cleat at Top Corner of Inside Face of Panel
- 2 Space Cleats Evenly at top edge of inside face of panel
- 3 Attach top to Pedestal with #SCR0680 screws thru holes in Pedestal interior top
- 4 Locate Top flush with back and outer edges of End panels. Leave excess overhang to the front.

- Assembly should be performed on a clean flat floor.
- Verify all items are received before assembling.

Tools

- #2 Phillips Screwdriver
- 5mm wrench

Item #	Part #	Description	Quantity
1	ISA10035	WorkSurface 60"	1
2	ISA10037	Inner End Panel Left/Right	1
3	ISA10039	Outer End Panel Left/Right	1
4	ISA10043	Modesty Panel 60"	1
5	ISA50021	Pedestal Subassembly	1
6	ISA130015	File Drawer Subassembly	1
7	ISA130019	File Drawer Assembly w/lock	1
8	BKT1657	Stiffner Bracket for WorkSurface	1
9	BRB0442	#235 Cleat	1
10	BRB0441	Steel Cleats	2
11	CTR21504	Bolts	8
12	CTR21541	Cam Locks	8
13	DWL0027	Dowel 1 Inch	8
14	GLI0191	Insert Nuts for Glides	3
15	GLI0212	Hex-Base Glides	3
16	SCR0680	Screw 1-5/8 Inch	6
17	SCR2507	Screw 5/8 Inch	16
18	SPC4898	Spacer	1

Integrate Assembly Instructions
Single Pedestal Desk (60") (File/File)

(Part No. I60DKSP)

STEP 1: ATTACH CLEATS TO THE END PANELS

Locate cleat (Item 9) at top corner of inside face of Inner End Panel (Item 2) and fasten it with the Screws (Item 17) in the holes provided. (See Fig. 1a)

Place the Outer End Panel (Item 3) on a flat surface. Space the 2 Steel Cleats (item 10) evenly on the top edge of inside face of panel and fasten with the Screws (Item 17) to the bottom panel. (See Fig. 1b)

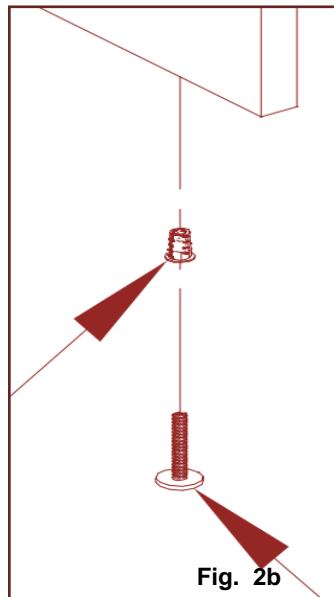
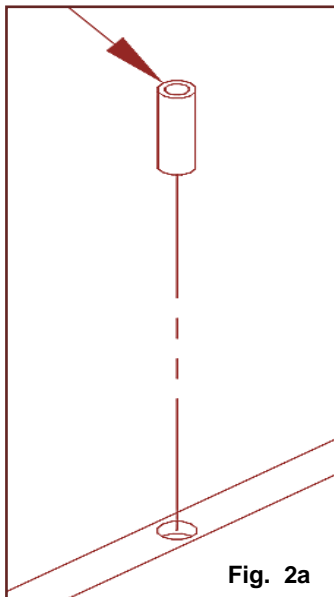
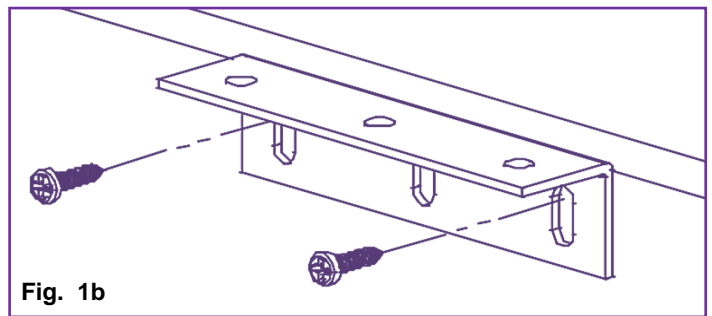
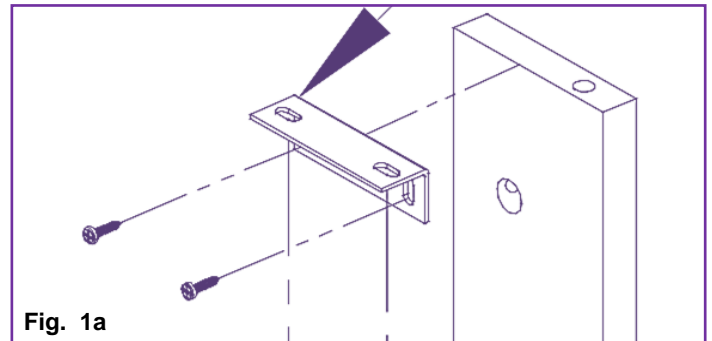

STEP 2: INSERT GLIDES AND SPACER TO PANELS

Insert 3 Glide Nuts (Item 14) each in the holes provided at the bottom edges on the End panels and Screw the Hex-Base Glides (Item 15) each in the Glide Nut. (See Figure 2b).

Insert the Spacer (item 18) in the hole provided on the top of the Modesty Back panel (Item 4). (See Figure 2a).

STEP 3: INSERT BOLTS, DOWELS AND CAM-LOCKS TO PANELS

Insert 4 cams (Item 12) each in the holes provided on the Modesty Panel (item 4) and Inner End panel (Item 2). (See Fig. 3b). Insert 4 wood dowels (Item 13) and screw 4 Connecting Bolts (Item 11) each in the holes provided on Outer End panel (item 3) and Modesty Panel (See Figure 3a).

Place the Inner and Outer End panels at right angles on the Modesty Panel so that the Dowels and Bolts are inserted into the pre-drilled holes on the edge of the panels.

Twist-lock all the 8 cams with a Philips screw-driver to the Connecting bolts on the panels.

Your Modesty Panel should be assembled with cleats on the top of the Inner and Outer end panels.

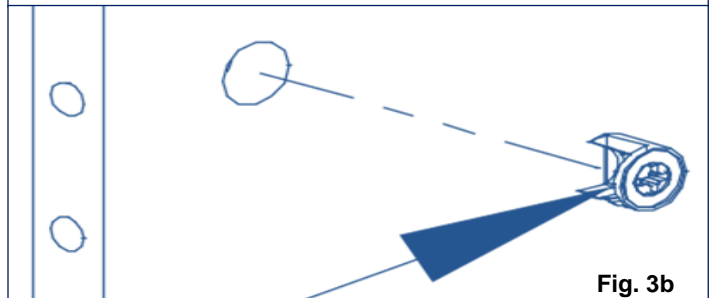
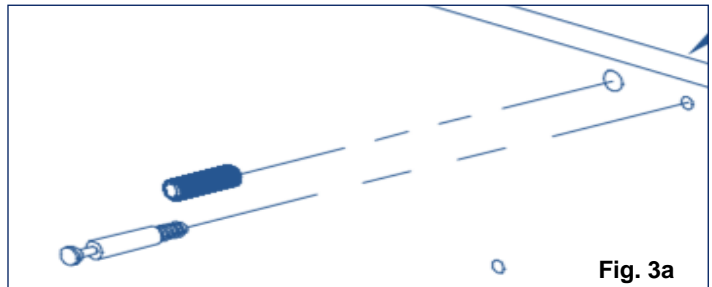

Integrate Assembly Instructions
Single Pedestal Desk (60") (File/File)

(Part No. I60DKSP)

STEP 4: ATTACH THE WORKSURFACE

Place the Worksurface (Item 1) on the Pedestal Subassembly (Item 5) and so that the pre-installed Stiffener bracket (Item 8) is in the front of the desk

Attach top to the Pedestal with 6 screws (Item 16) each thru holes in Pedestal interior top. (See Figure 4). Locate Top flush with back and outer edges of Pedestal and End panel. Leave excess overhang to the front.

Screw the 3 steel cleats (previously fastened on the top of Inner and outer end panels) to the Worksurface with 5/8 " Screws (item 17).

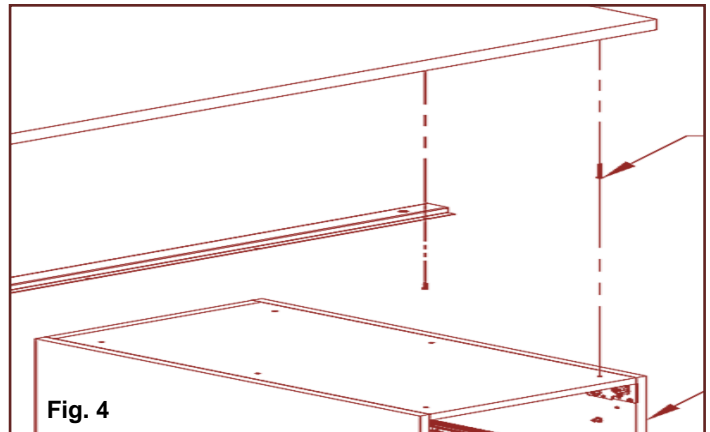

Fig. 4

STEP 5: INSERT DRAWERS IN THE ASSEMBLED PRODUCT

Locate the Drawer Glides as shown in Figure 5a on the Drawer Assembly (Items 6, and 7). Locate the Glide-Insert as shown in Figure 5b on the Pedestal Assembly (item 5) of the currently assembled product.

Carefully, insert the Drawers by placing the glide on the rollers of the glide-insert in the Pedestals as shown in right Figure 5c. The File drawer assembly with lock (Item 7) should be inserted on the top and the File drawer without lock (Item 6) should be inserted at the bottom.

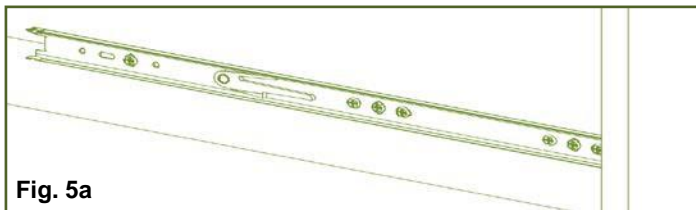

Fig. 5a

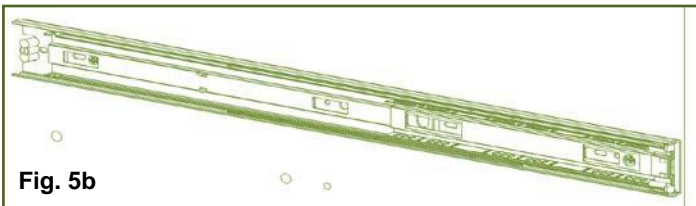

Fig. 5b

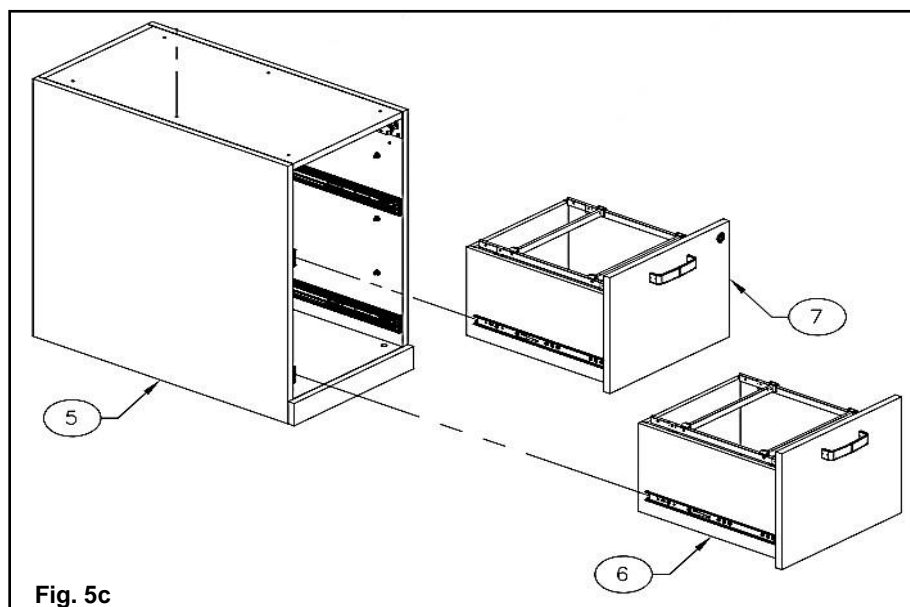
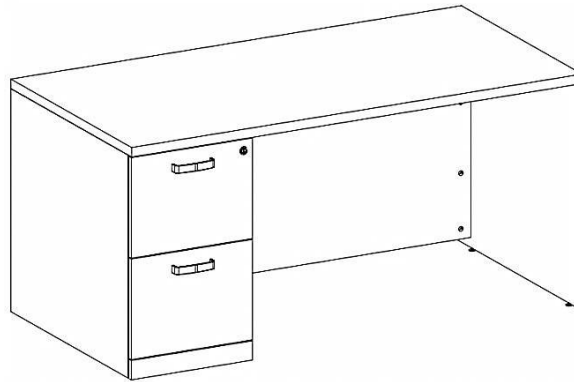

Fig. 5c

Integrate Assembly Instructions
Single Pedestal Desk (60") (File/File)
(Part No. I60DKSP)

Your Final Assembled Product should look like below (Based on the Ordered Configuration)



Single Pedestal Left (File/File) Configuration

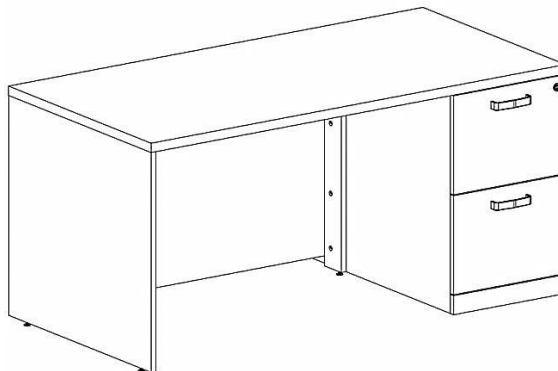

Single Pedestal Right (File/File) Configuration



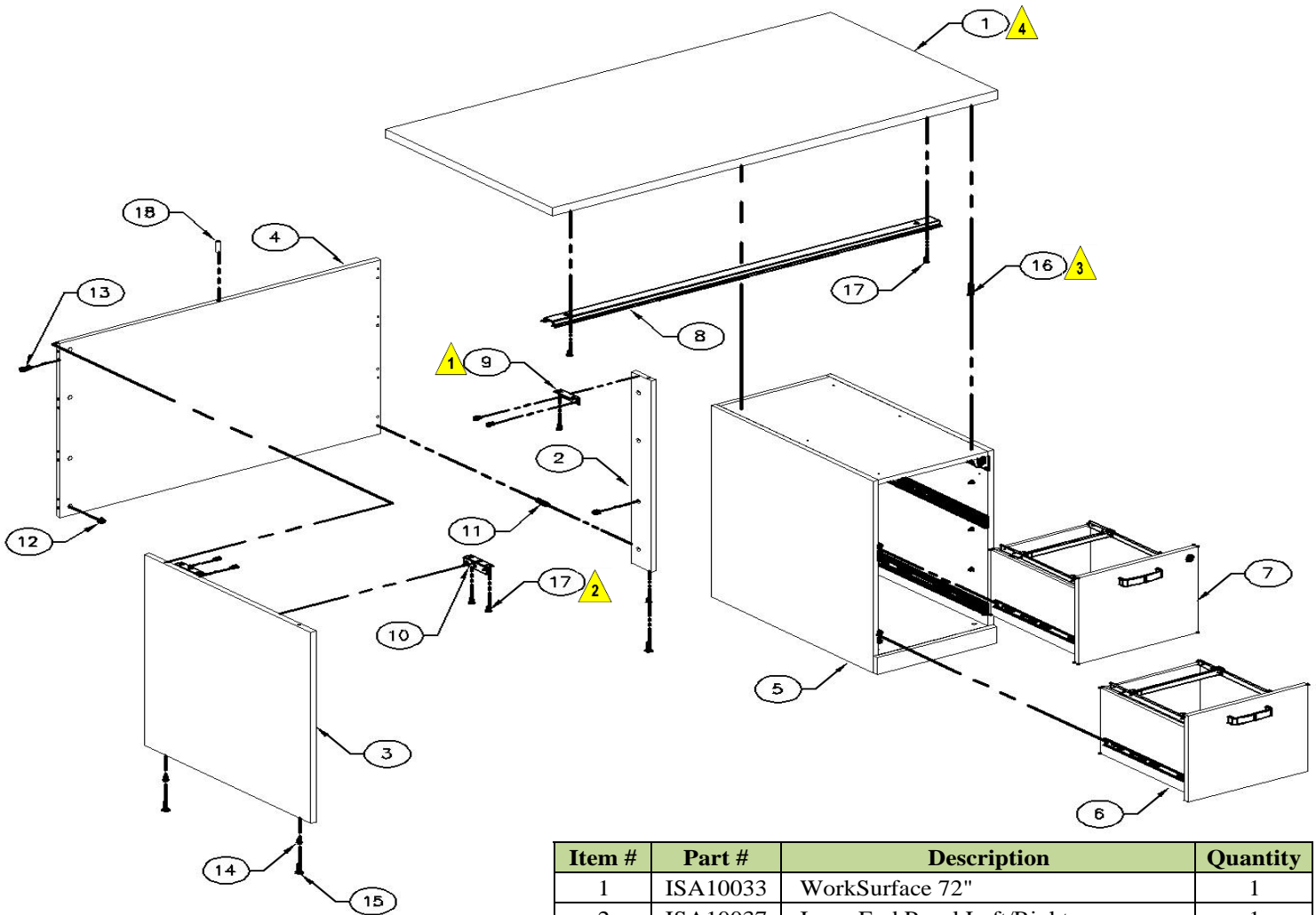

Integrate Assembly Instructions
Single Pedestal Desk (72") (File/File)
(Part No. I72DKSP)



Warnings

-  Do not over-tighten the screws.
- Do not turn cam-locks more than 180°.

Note

-  1 Locate Cleat at Top Corner of Inside Face of Panel
-  2 Space Cleats Evenly at top edge of inside face of panel
-  3 Attach top to Pedestal with #SCR0680 screws thru holes in Pedestal interior top
-  4 Locate Top flush with back and outer edges of End panels.
-  4 Leave excess overhang to the front.

- Assembly should be performed on a clean flat floor.
- Verify all items are received before assembling.

Tools

- #2 Phillips Screwdriver
- 5mm wrench

Item #	Part #	Description	Quantity
1	ISA10033	WorkSurface 72"	1
2	ISA10037	Inner End Panel Left/Right	1
3	ISA10039	Outer End Panel Left/Right	1
4	ISA10041	Modesty Panel 72"	1
5	ISA50021	Pedestal Subassembly	1
6	ISA130015	File Drawer Subassembly	1
7	ISA130019	File Drawer Assembly w/lock	1
8	BKT1657	Stiffner Bracket for WorkSurface	1
9	BRB0442	#235 Cleat	1
10	BRB0441	Steel Cleats	2
11	CTR21504	Bolts	8
12	CTR21541	Cam Locks	8
13	DWL0027	Dowel 1 Inch	8
14	GLI0191	Insert Nuts for Glides	3
15	GLI0212	Hex-Base Glides	3
16	SCR0680	Screw 1-5/8 Inch	6
17	SCR2507	Screw 5/8 Inch	16
18	SPC4898	Spacer	1

Integrate Assembly Instructions
Single Pedestal Desk (72") (File/File)

(Part No. I72DKSP)

STEP 1: ATTACH CLEATS TO THE END PANELS

Locate cleat (Item 9) at top corner of inside face of Inner End Panel (Item 2) and fasten it with the Screws (Item 17) in the holes provided. (See Fig. 1a)

Place the Outer End Panel (Item 3) on a flat surface. Space the 2 Steel Cleats (item 10) evenly on the top edge of inside face of panel and fasten with the Screws (Item 17) to the bottom panel. (See Fig. 1b)

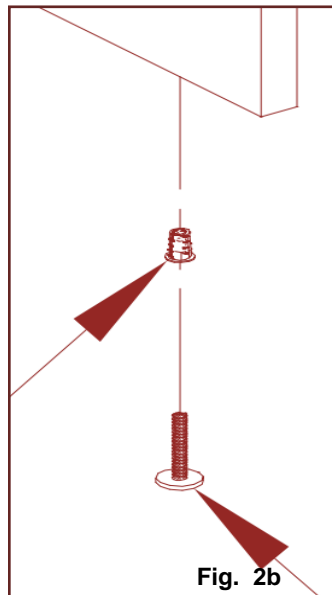
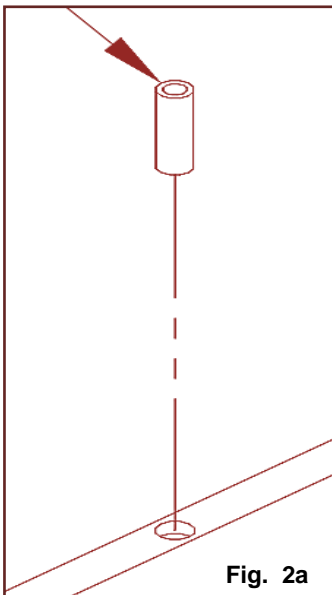
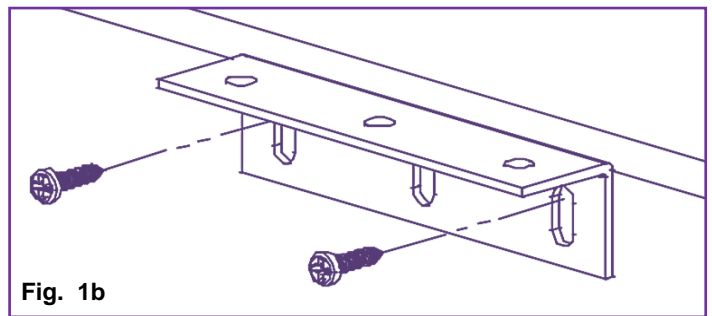
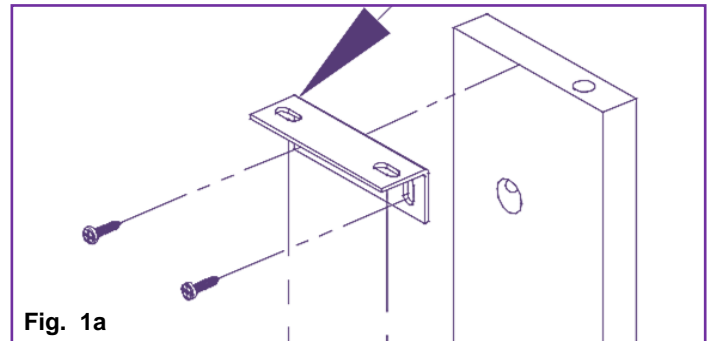

STEP 2: INSERT GLIDES AND SPACER TO PANELS

Insert 3 Glide Nuts (Item 14) each in the holes provided at the bottom edges on the End panels and Screw the Hex-Base Glides (Item 15) each in the Glide Nut. (See Figure 2b).

Insert the Spacer (item 18) in the hole provided on the top of the Modesty Back panel (Item 4). (See Figure 2a).

STEP 3: INSERT BOLTS, DOWELS AND CAM-LOCKS TO PANELS

Insert 4 cams (Item 12) each in the holes provided on the Modesty Panel (item 4) and Inner End panel (Item 2). (See Fig. 3b). Insert 4 wood dowels (Item 13) and screw 4 Connecting Bolts (Item 11) each in the holes provided on Outer End panel (item 3) and Modesty Panel (See Figure 3a).

Place the Inner and Outer End panels at right angles on the Modesty Panel so that the Dowels and Bolts are inserted into the pre-drilled holes on the edge of the panels.

Twist-lock all the 8 cams with a Philips screw-driver to the Connecting bolts on the panels.

Your Modesty Panel should be assembled with cleats on the top of the Inner and Outer end panels.

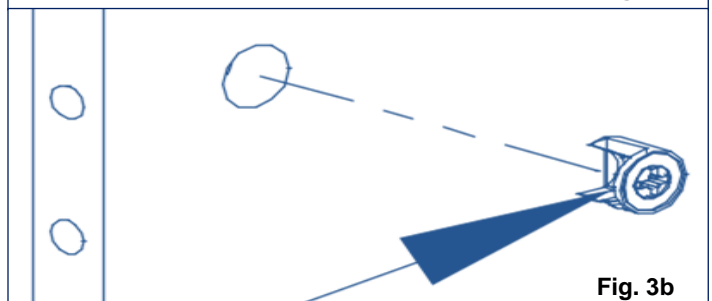
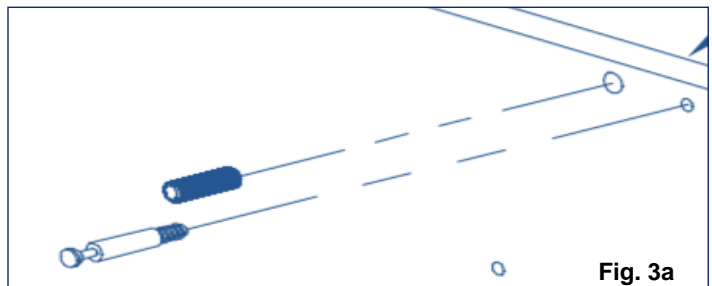

Integrate Assembly Instructions
Single Pedestal Desk (72") (File/File)

(Part No. I72DKSP)

STEP 4: ATTACH THE WORKSURFACE

Place the Worksurface (Item 1) on the Pedestal Subassembly (Item 5) and so that the pre-installed Stiffener bracket (Item 8) is in the front of the desk

Attach top to the Pedestal with 6 screws (Item 16) each thru holes in Pedestal interior top. (See Figure 4). Locate Top flush with back and outer edges of Pedestal and End panel. Leave excess overhang to the front.

Screw the 3 steel cleats (previously fastened on the top of Inner and outer end panels) to the Worksurface with 5/8 " Screws (item 17).

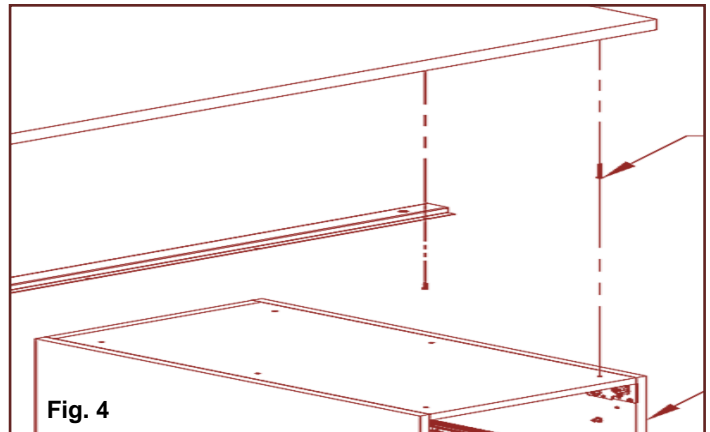

Fig. 4

STEP 5: INSERT DRAWERS IN THE ASSEMBLED PRODUCT

Locate the Drawer Glides as shown in Figure 5a on the Drawer Assembly (Items 6, and 7). Locate the Glide-Insert as shown in Figure 5b on the Pedestal Assembly (item 5) of the currently assembled product.

Carefully, insert the Drawers by placing the glide on the rollers of the glide-insert in the Pedestals as shown in right Figure 5c. The File drawer assembly with lock (Item 7) should be inserted on the top and the File drawer without lock (Item 6) should be inserted at the bottom.

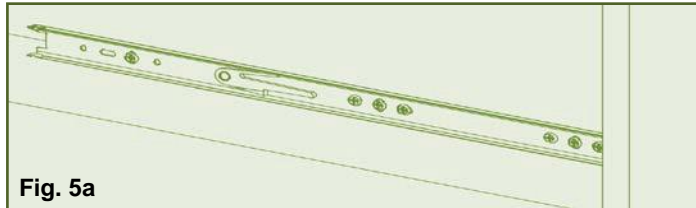

Fig. 5a

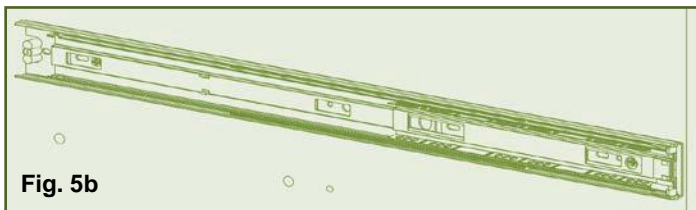

Fig. 5b

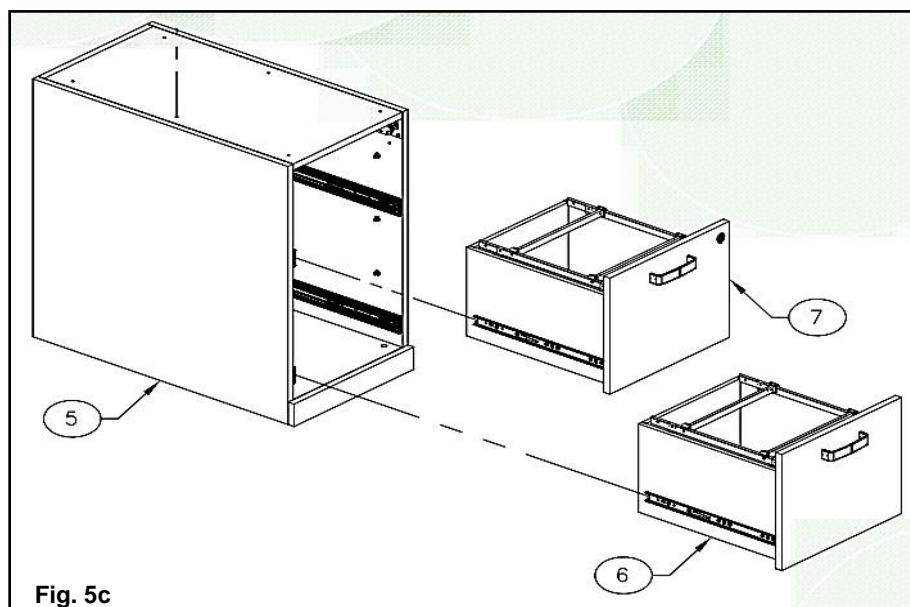
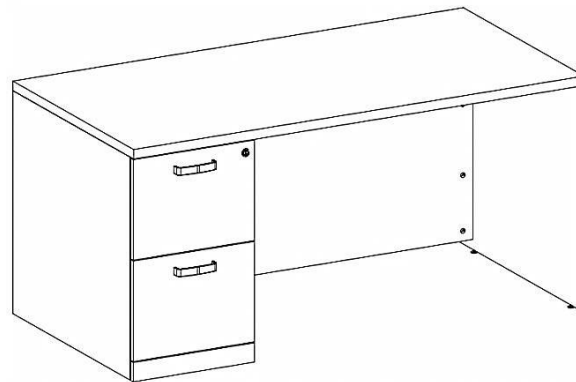

Fig. 5c

Integrate Assembly Instructions
Single Pedestal Desk (72") (File/File)
(Part No. I72DKSP)

Your Final Assembled Product should look like below (Based on the Ordered Configuration)



Single Pedestal Left (File/File) Configuration

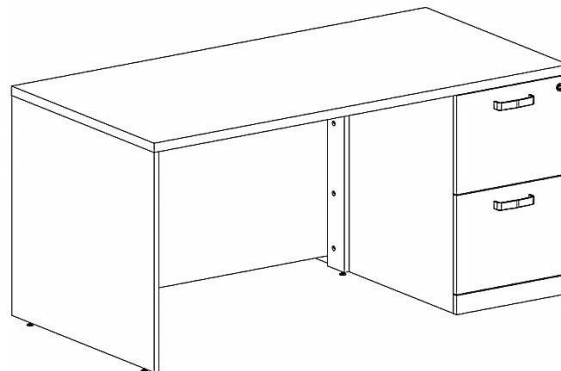

Single Pedestal Right (File/File) Configuration

Integrate Assembly Instructions
Single Pedestal Desk (60") (Pencil/Drawer/File)
(Part No. I60DKSP)

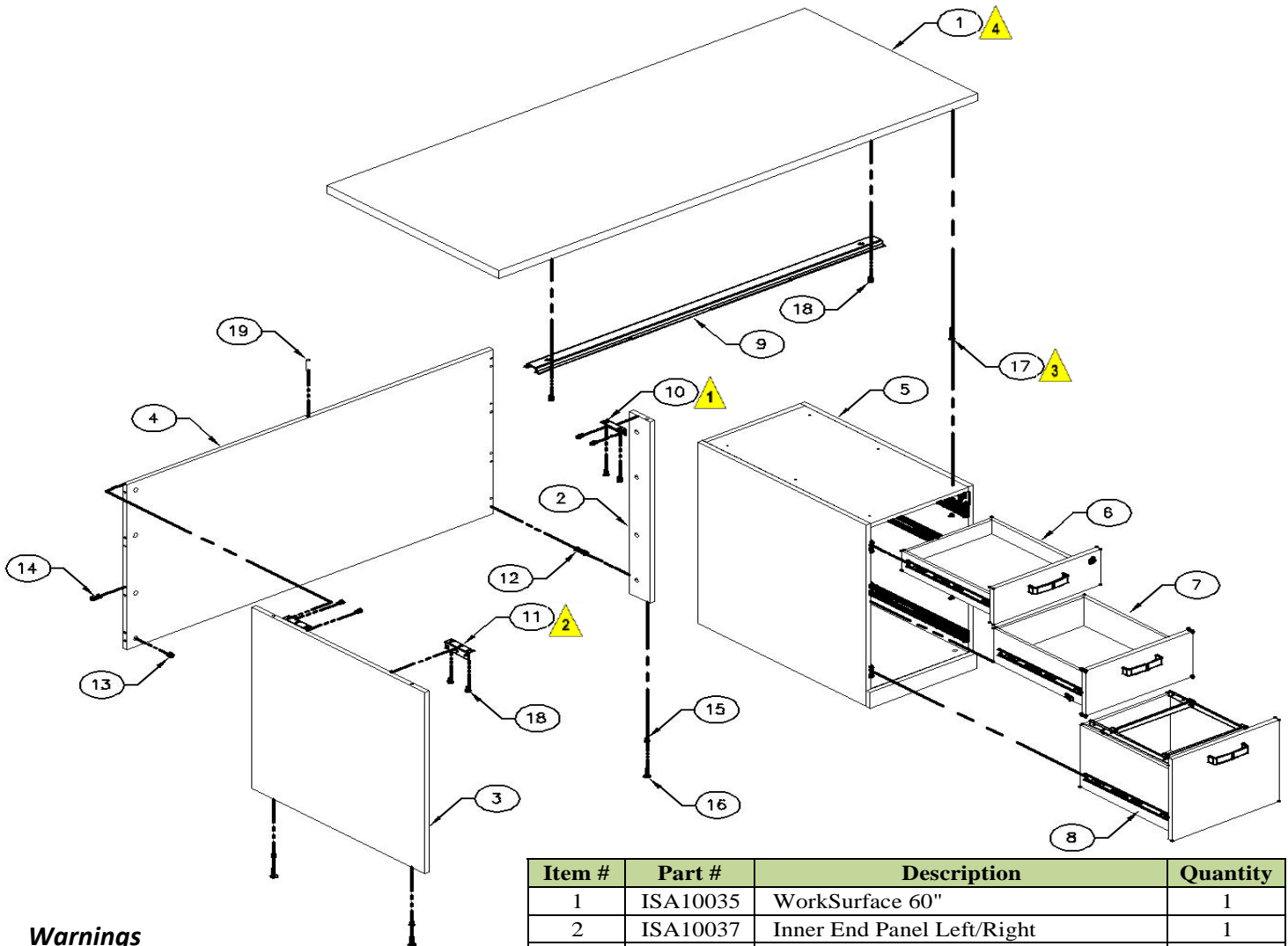

Warnings

- Do not over-tighten the screws.
- Do not turn cam-locks more than 180°.

Note

- 1 Locate Cleat at Top Corner of Inside Face of Panel
- 2 Space Cleats Evenly at top edge of inside face of panel
- 3 Attach top to Pedestal with #SCR0680 screws thru holes in Pedestal interior top
- 4 Locate Top flush with back and outer edges of End panels.
- 4 Leave excess overhang to the front.

- Assembly should be performed on a clean flat floor.
- Verify all items are received before assembling.

Tools

- #2 Phillips Screwdriver
- 5mm wrench

Item #	Part #	Description	Quantity
1	ISA10035	WorkSurface 60"	1
2	ISA10037	Inner End Panel Left/Right	1
3	ISA10039	Outer End Panel Left/Right	1
4	ISA10043	Modesty Panel 60"	1
5	ISA50017	Pedestal Subassembly	1
6	ISA130001	Pencil Drawer Subassembly w/lock	1
7	ISA130005	Box Drawer Subassembly	1
8	ISA130015	File Drawer Subassembly	1
9	BKT1657	Stiffner Bracket for WorkSurface	1
10	BRB0442	#235 Cleat	1
11	BRB0441	Steel Cleats	2
12	CTR21504	Bolts	8
13	CTR21541	Cam Locks	8
14	DWL0027	Dowel 1 Inch	8
15	GLI0191	Insert Nuts for Glides	3
16	GLI0212	Hex-Base Glides	3
17	SCR0680	Screw 1-5/8 Inch	6
18	SCR2507	Screw 5/8 Inch	16
19	SPC4898	Spacer	1

STEP 1: ATTACH CLEATS TO THE END PANELS

Locate cleat (Item 10) at top corner of inside face of Inner End Panel (Item 2) and fasten it with the Screws (Item 18) in the holes provided. (See Fig. 1a)

Place the Outer End Panel (Item 3) on a flat surface. Space the 2 Steel Cleats (item 11) evenly on the top edge of inside face of panel and fasten with the Screws (Item 18) to the bottom panel. (See Fig. 1b)

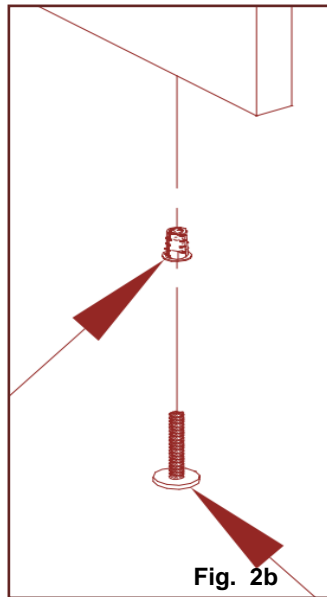
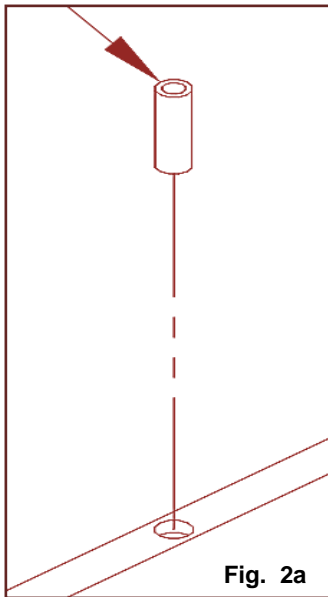
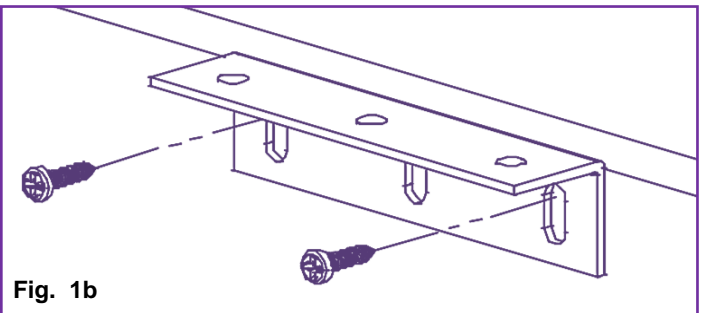
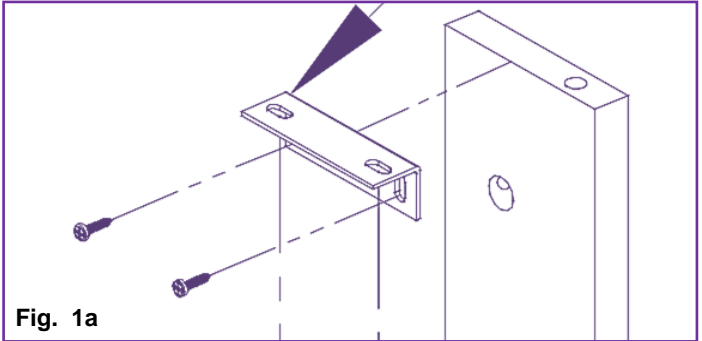

STEP 2: INSERT GLIDES AND SPACER TO PANELS

Insert 3 Glide Nuts (Item 15) each in the holes provided at the bottom edges on the End panels and Screw the Hex-Base Glides (Item 16) each in the Glide Nut. (See Figure 2b).

Insert the Spacer (item 19) in the hole provided on the top of the Modesty Back panel (Item 4). (See Figure 2a).

STEP 3: INSERT BOLTS, DOWELS AND CAM-LOCKS TO PANELS

Insert 4 cams (Item 13) each in the holes provided on the Modesty Panel (item 4) and Inner End panel (Item 2). (See Fig. 3b). Insert 4 wood dowels (Item 14) and screw 4 Connecting Bolts (Item 12) each in the holes provided on Outer End panel (item 3) and Modesty Panel (See Figure 3a).

Place the Inner and Outer End panels at right angles on the Modesty Panel so that the Dowels and Bolts are inserted into the pre-drilled holes on the edge of the panels.

Twist-lock all the 8 cams with a Philips screw-driver to the Connecting bolts on the panels.

Your Modesty Panel should be assembled with cleats on the top of the Inner and Outer end panels.

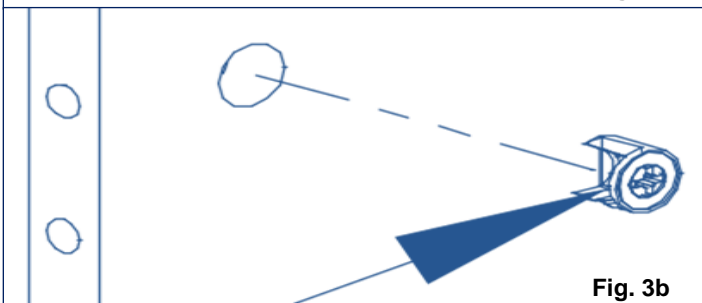
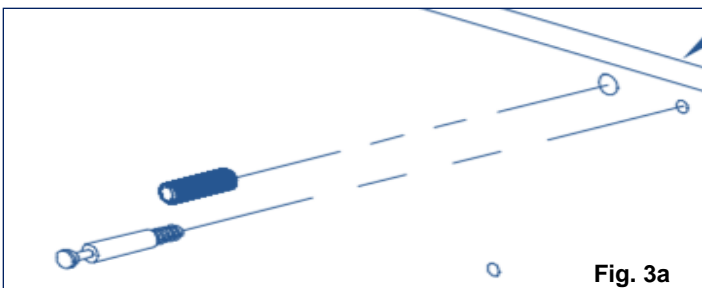

STEP 4: ATTACH THE WORKSURFACE

Place the Worksurface (Item 1) on the Pedestal Subassembly (Item 5) and so that the pre-installed Stiffener bracket (Item 9) is in the front of the desk

Attach top to the Pedestal with 6 screws (Item 17) each thru holes in Pedestal interior top. (See Figure 4). Locate Top flush with back and outer edges of Pedestal and End panel. Leave excess overhang to the front.

Screw the 3 steel cleats (previously fastened on the top of Inner and outer end panels) to the Worksurface with 5/8 " Screws (item 18).

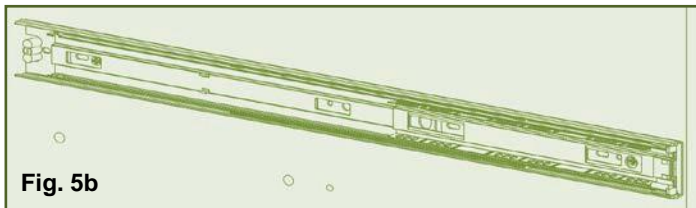
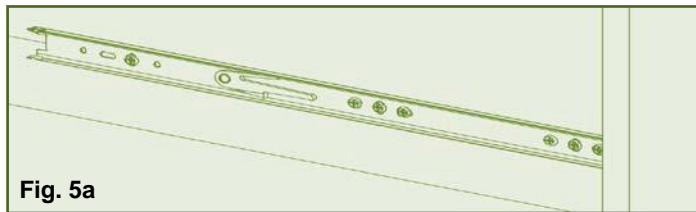
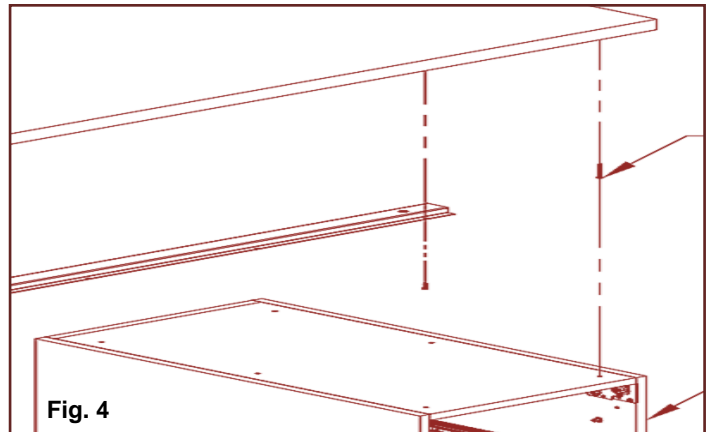

STEP 5: INSERT DRAWERS IN THE ASSEMBLED PRODUCT

Locate the Drawer Glides as shown in Figure 5a on the Drawer Assembly (Items 6, 7 and 8). Locate the Glide-Insert as shown in Figure 5b on the Pedestal Assembly (item 5) of the currently assembled product.

Carefully, insert the Drawers by placing the glide on the rollers of the glide-insert in the Pedestals as shown in right Figure 5c. The Pencil drawer assembly with lock (Item 6) should be inserted on the top and the File drawer (Item 8) should be inserted at the bottom. The Box drawer is inserted in the middle.

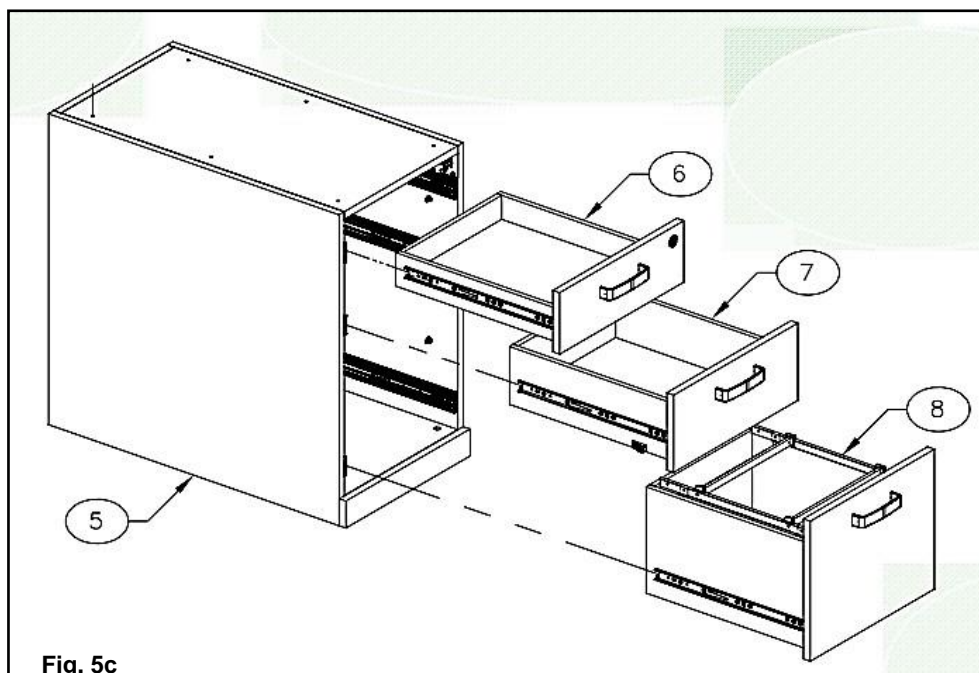

Integrate Assembly Instructions
Single Pedestal Desk (60") (Pencil/Drawer/File)
(Part No. I60DKSP)

Your Final Assembled Product should look like below (Based on the Ordered Configuration)

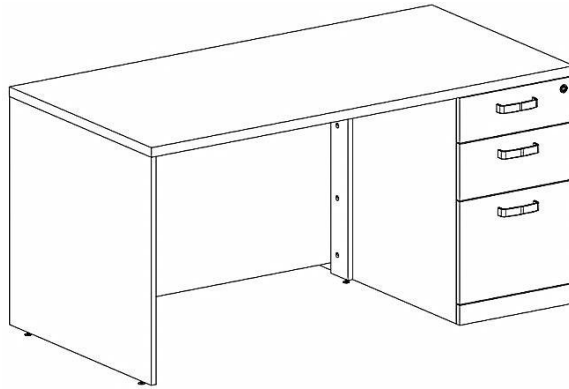



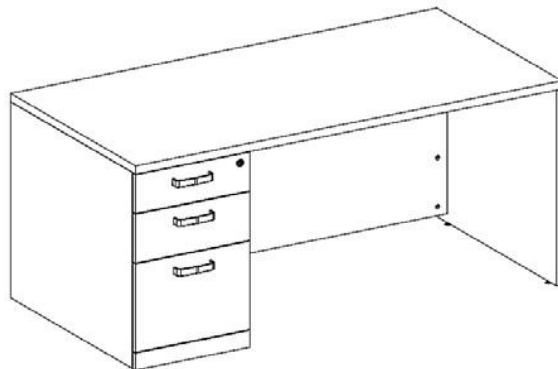





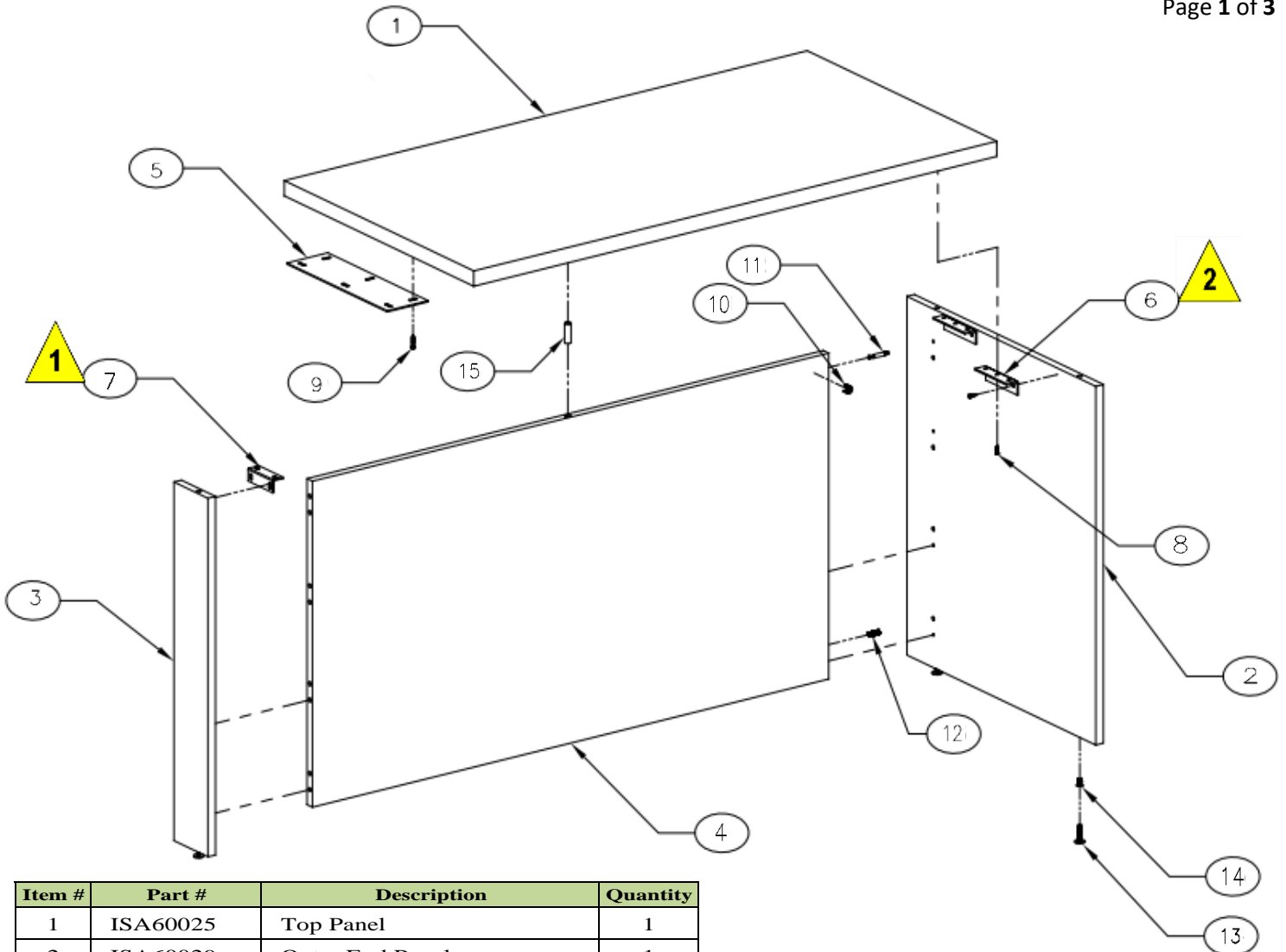

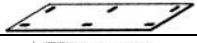
Single Pedestal Right (Pencil/Drawer/File) Configuration



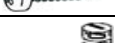

Single Pedestal Left (Pencil/Drawer/File) Configuration

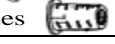
Integrate Assembly Instructions
L-Unit Extension (All sizes)
(Left/Right)





Item #	Part #	Description	Quantity
1	ISA60025	Top Panel	1
2	ISA60029	Outer End Panel	1
3	ISA60031	Inner End Panel	1
4	ISA60033	Modesty Panel	1
5	PDM95157B	Splice Plate 	1
6	BRB0441	Steel Cleat 	2
7	BRB0442	Cleat 	1
8	SCR2507	Screw 5/8 Inch 	16
9	SCR0681	Screw 3/4 Inch 	6
10	CTR21541	CamLocks 	8
11	CTR21504	Bolt, 7mm Dia. 	8
12	DWL0027	Wood Dowel 	8
13	GLI0212	Hex-Base Glides 	3
14	GLI0191	Insert Nuts for Glides 	3
15	SPC4898	Spacer 	1

Warnings

-  Do not over-tighten the screws.
-  Do not turn cam-locks more than 180°.

Note

-  Locate Cleat at Top Corner of Inside Face of Panel
-  Space Cleats Evenly at top edge of inside face of panel
- ✓ Assembly should be performed on a clean flat floor.
- ✓ Verify all items are received before assembling.

Tools

- ✓ # 2 Phillips Screwdriver
- ✓ 5mm wrench

STEP 1: ATTACH CLEATS TO THE END PANELS

Locate cleat (Item 7) at top corner of inside face of Inner End Panel (Item 3) and fasten it with the Screws (Item 9) in the holes provided. (See Fig. 1a)

Place the Outer End Panel (Item 2) on a flat surface. Space the 2 Steel Cleats (item 6) evenly on the top edge of inside face of panel and fasten with the Screws (Item 9) to the panel. (See Fig. 1b)

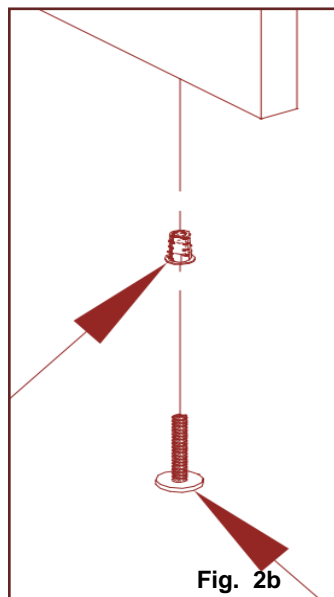
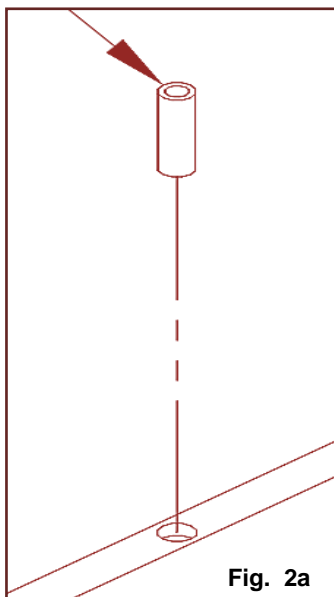
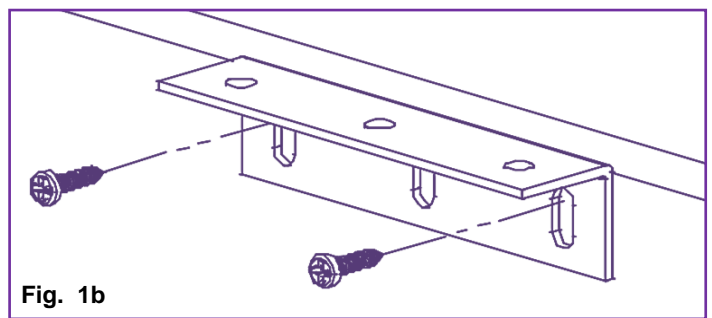
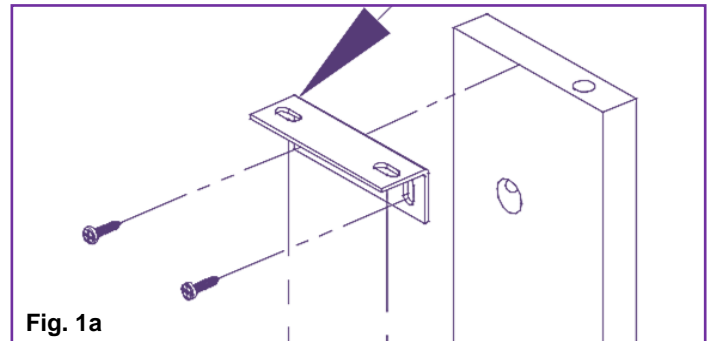

STEP 2: INSERT GLIDES AND SPACER TO PANELS

Insert 3 Glide Nuts (Item 14) each in the holes provided at the bottom edges on the End panels and Screw the Hex-Base Glides (Item 13) each in the Glide Nut. (See Figure 2b).

Insert the Spacer (item 15) in the hole provided on the top of the Modesty Back panel (Item 4). (See Figure 2a).

STEP 3: INSERT BOLTS, DOWELS AND CAM-LOCKS TO PANELS

Insert 8 cams (Item 10) in the holes provided on the Modesty Panel (item 4) (See Fig. 3b). Insert 4 wood dowels (Item 12) and screw 4 Connecting Bolts (Item 11) each in the holes provided on Outer End panel (item 2) and Inner End Panel (Item 3)(See Figure 3a).

Place the Inner and Outer End panels at right angles on the Modesty Panel so that the Dowels and Bolts are inserted into the pre-drilled holes on the edge of the panels.

Twist-lock all the 8 cams with a Philips screw-driver to the Connecting bolts on the panels.

Your Base of the unit along with Modesty Panel should be assembled with cleats on the top of the Inner and Outer end panels.

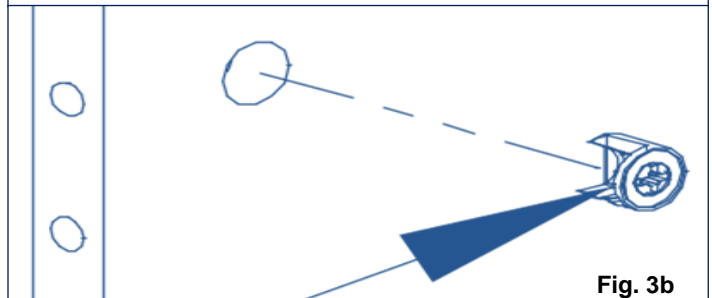
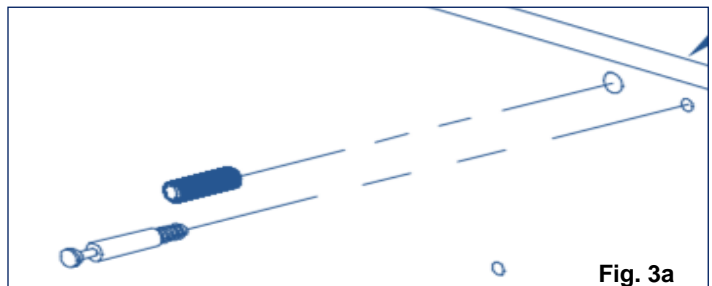

STEP 4: ATTACH THE TOP PANEL

Place the Top Panel (Item 1) on a flat surface and attach the Splice Plate (Item 5) with Screws (Item 9) to the panel. This Splice Plate will also attach the L-Unit Extension to the Desk Worksurface.

Attach the top panel to the base assembly with screws (Item 8) with the 3 steel cleats (previously fastened on the top of Left and Right End panels) (See Figure 4). Locate Top flush with back and outer edges of Left and Right End panel.

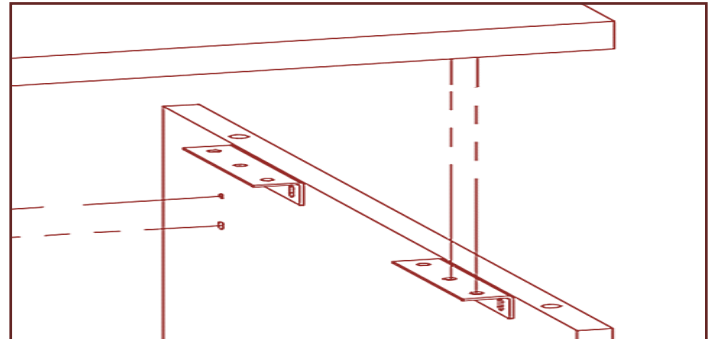

Your Final Assembled Product should look like below (Based on the Ordered Configuration)

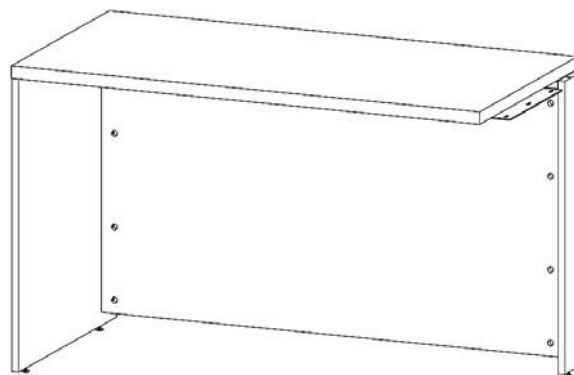



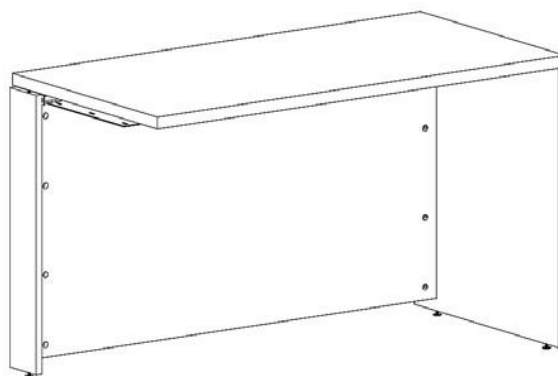



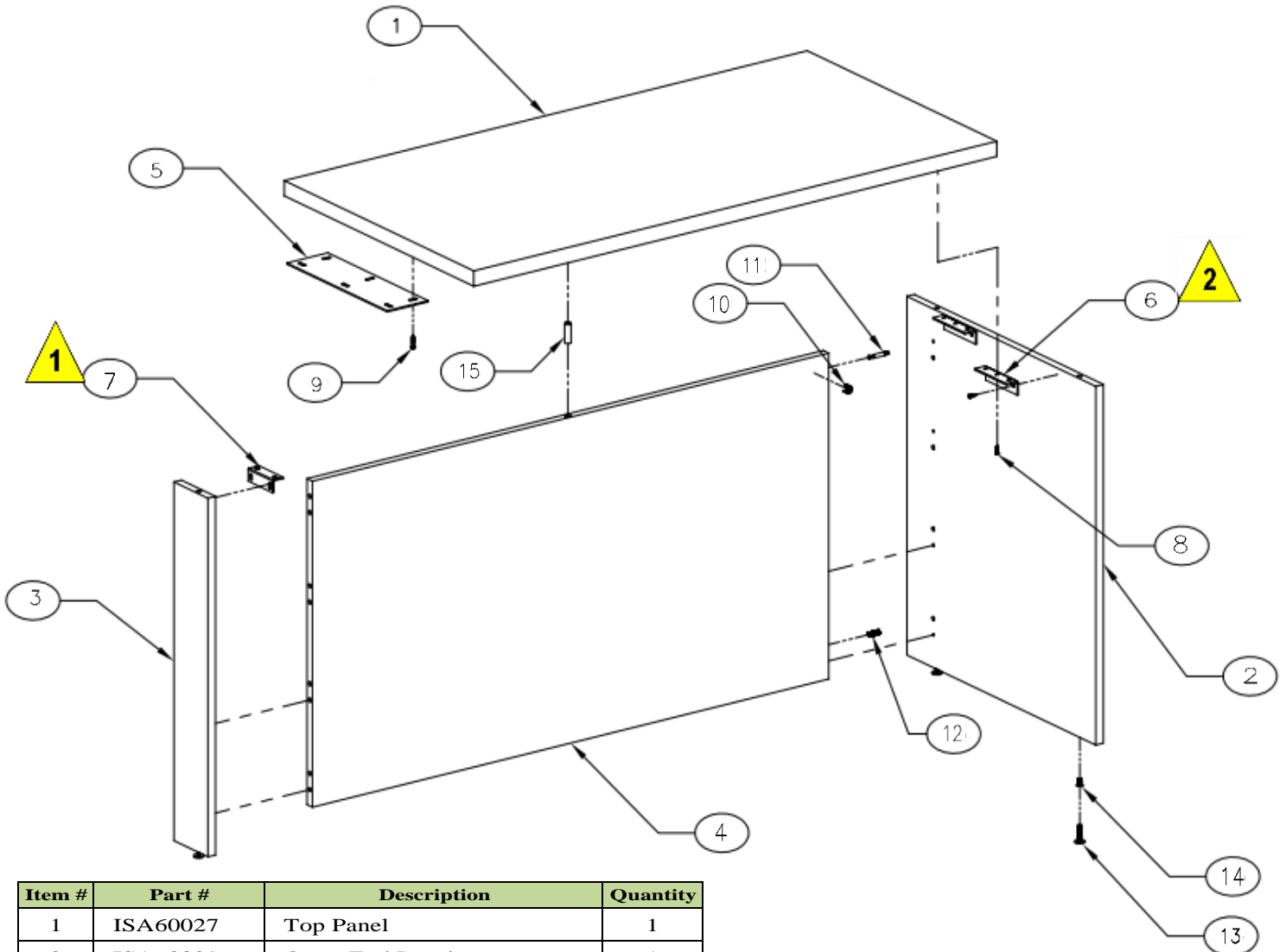

L-Unit Return Left

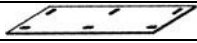
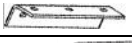

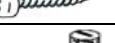

L-Unit Return Right

Integrate Assembly Instructions
L-Unit Extension 48" (Left/Right)
(Part No. I48Ex)





Item #	Part #	Description	Quantity
1	ISA60027	Top Panel	1
2	ISA60029	Outer End Panel	1
3	ISA60031	Inner End Panel	1
4	ISA60035	Modesty Panel	1
5	PDM95157B	Splice Plate 	1
6	BRB0441	Steel Cleat 	2
7	BRB0442	Cleat 	1
8	SCR2507	Screw 5/8 Inch 	16
9	SCR0681	Screw 3/4 Inch 	6
10	CTR21541	CamLocks 	8
11	CTR21504	Bolt, 7mm Dia. 	8
12	DWL0027	Wood Dowel 	8
13	GLI0212	Hex-Base Glides 	3
14	GLI0191	Insert Nuts for Glides 	3
15	SPC4898	Spacer 	1

Warnings

-  Do not over-tighten the screws.
-  Do not turn cam-locks more than 180°.

Note

-  Locate Cleat at Top Corner of Inside Face of Panel
-  Space Cleats Evenly at top edge of inside face of panel
- ✓ Assembly should be performed on a clean flat floor.
- ✓ Verify all items are received before assembling.

Tools

- ✓ # 2 Phillips Screwdriver
- ✓ 5mm wrench

STEP 1: ATTACH CLEATS TO THE END PANELS

Locate cleat (Item 7) at top corner of inside face of Inner End Panel (Item 3) and fasten it with the Screws (Item 9) in the holes provided. (See Fig. 1a)

Place the Outer End Panel (Item 2) on a flat surface. Space the 2 Steel Cleats (item 6) evenly on the top edge of inside face of panel and fasten with the Screws (Item 9) to the panel. (See Fig. 1b)

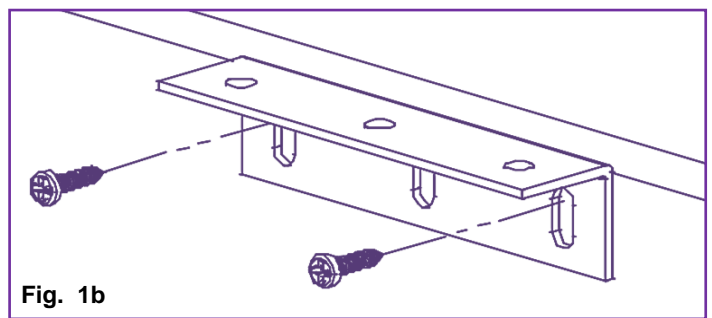
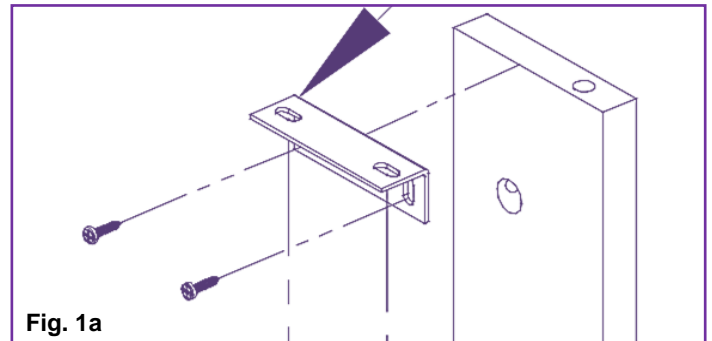

STEP 2: INSERT GLIDES AND SPACER TO PANELS

Insert 3 Glide Nuts (Item 14) each in the holes provided at the bottom edges on the End panels and Screw the Hex-Base Glides (Item 13) each in the Glide Nut. (See Figure 2b).

Insert the Spacer (item 15) in the hole provided on the top of the Modesty Back panel (Item 4). (See Figure 2a).

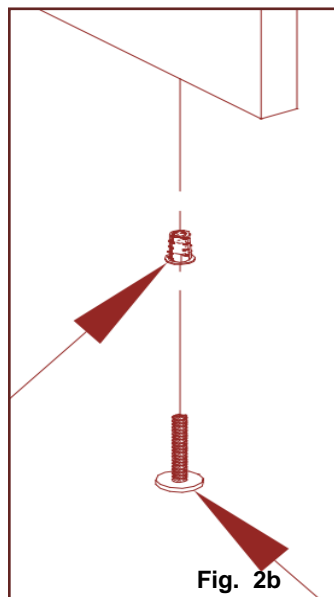
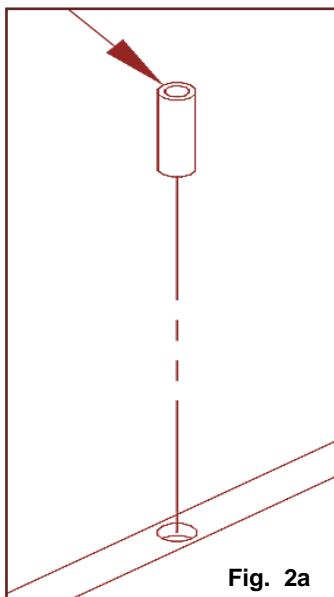

STEP 3: INSERT BOLTS, DOWELS AND CAM-LOCKS TO PANELS

Insert 8 cams (Item 10) in the holes provided on the Modesty Panel (item 4) (See Fig. 3b). Insert 4 wood dowels (Item 12) and screw 4 Connecting Bolts (Item 11) each in the holes provided on Outer End panel (item 2) and Inner End Panel (Item 3)(See Figure 3a).

Place the Inner and Outer End panels at right angles on the Modesty Panel so that the Dowels and Bolts are inserted into the pre-drilled holes on the edge of the panels.

Twist-lock all the 8 cams with a Philips screw-driver to the Connecting bolts on the panels.

Your Base of the unit along with Modesty Panel should be assembled with cleats on the top of the Inner and Outer end panels.

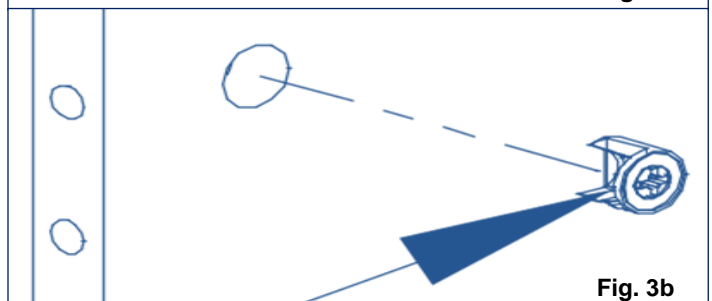
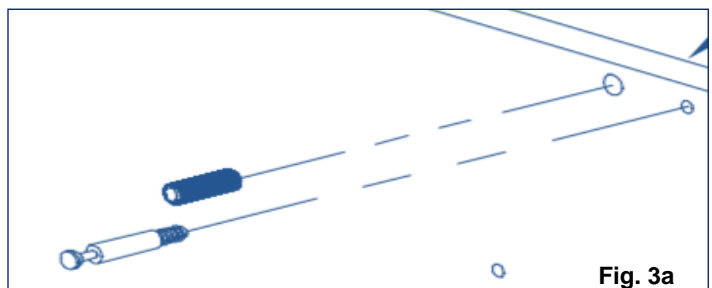

Integrate Assembly Instructions
L-Unit Extension 48" (Left/Right)

(Part No. I48Ex)

Page 3 of 3

STEP 4: ATTACH THE TOP PANEL

Place the Top Panel (Item 1) on a flat surface and attach the Splice Plate (Item 5) with Screws (Item 9) to the panel. This Splice Plate will also attach the L-Unit Extension to the Desk Worksurface.

Attach the top panel to the base assembly with screws (Item 8) with the 3 steel cleats (previously fastened on the top of Left and Right End panels) (See Figure 4). Locate Top flush with back and outer edges of Left and Right End panel.

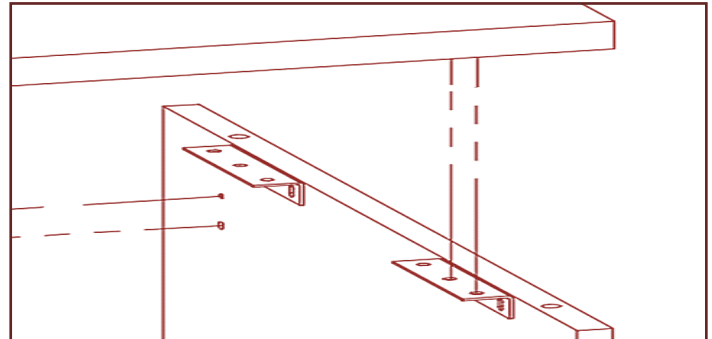

Your Final Assembled Product should look like below (Based on the Ordered Configuration)

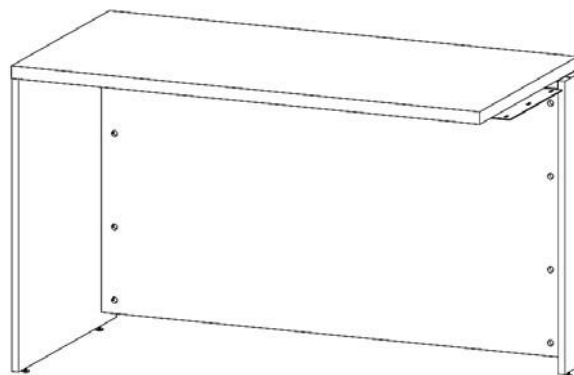

L-Unit Return Left

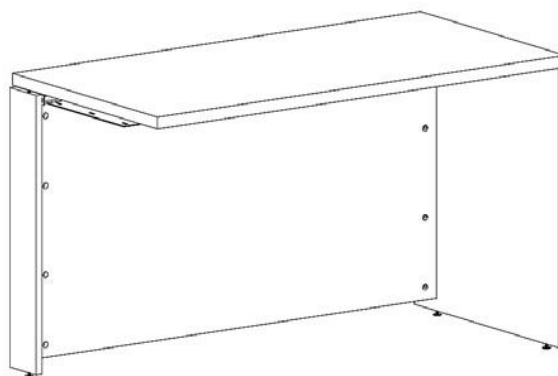

L-Unit Return Right

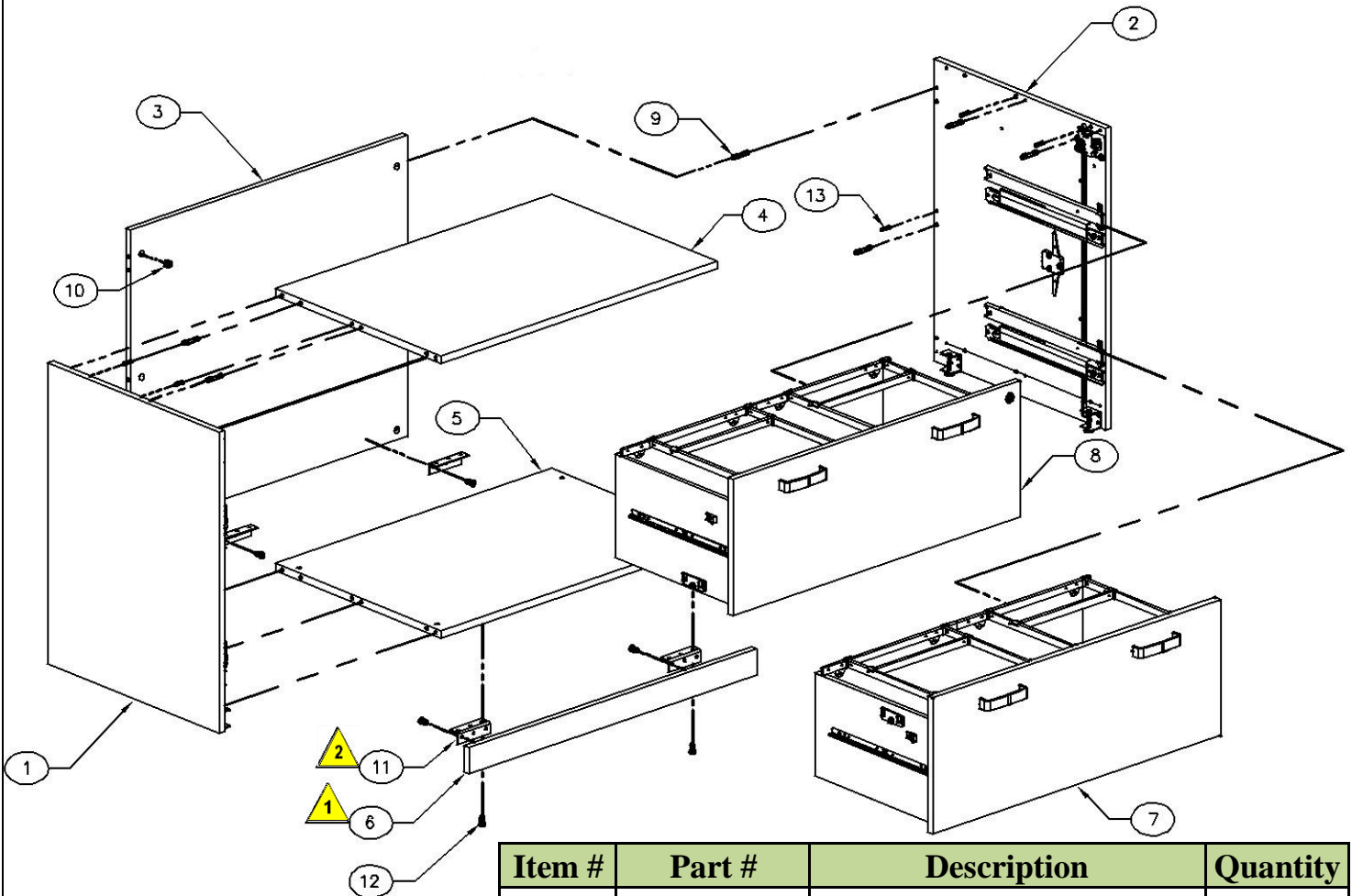

Integrate Assembly Instructions
Two Drawer Lateral File WSS
(Part No. I2LFW)



Warnings





-  Do not over-tighten the screws.
- Do not turn cam-locks more than 180°.

Note

-  1 Mount Toe-Kick flush with top of Bottom Panel
-  2 Space Cleats evenly on the front and the back edge of Bottom Panel
- Assembly should be performed on a clean flat floor.
- Verify all items are received before assembling.

Tools

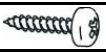
- ✓ #2 Phillips Screwdriver
- ✓ 5mm wrench

Item #	Part #	Description	Quantity
1	ISAEPL13	End Panel Left	1
2	ISAEPR17	End Panel Right	1
3	ISABP47	Back Panel	1
4	ISATIP53	Top Interior Panel (WSS)	1
5	ISABP55	Bottom Panel	1
6	ISATKP57	Toe Kick Panel	1
7	ISADA27	Drawer Assembly	1
8	ISADA29	Drawer Assembly with lock	1
9	CTR21504	Bolts 	18
10	CTR21541	Cam Locks 	18
11	BRB0441	Steel Cleats 	4
12	SCR2507	Screw 5/8 Inch 	24
13	DWL0027	Dowel 1 Inch 	18

Integrate Assembly Instructions
Two Drawer Lateral File WSS
(Part No. I2LFW)

STEP 1: ATTACH CLEATS TO THE BOTTOM PANEL

Place the Bottom Panel (Item 5) on a flat surface. Space the 4 Steel Cleats (item 11) evenly on the front and the back edge of bottom panel and fasten with the Screws (Item 12) to the bottom panel.

Mount Toe-Kick Panel (Item 6) flush with the top of Bottom Panel and fasten it with the Screws (Item 12) in the holes provided.

Place the Back Panel (Item 3) perpendicular to the Bottom panel and fasten the cleats to the back panel with the Screws.

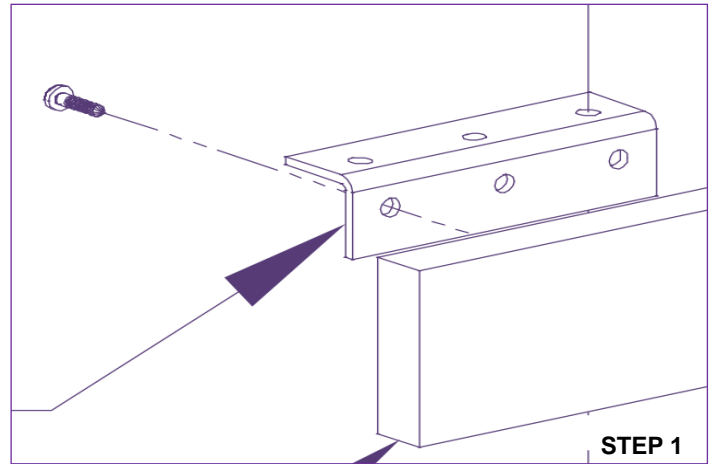

STEP 2: INSERT BOLTS AND DOWELS TO SIDE PANELS

Place the End Panel Left (Item 1) and End Panel Right (Item 2) on a flat surface. Insert 9 wood dowels (Item 13) and screw 9 Connecting Bolts (Item 9) each in the holes provided on both the panels.

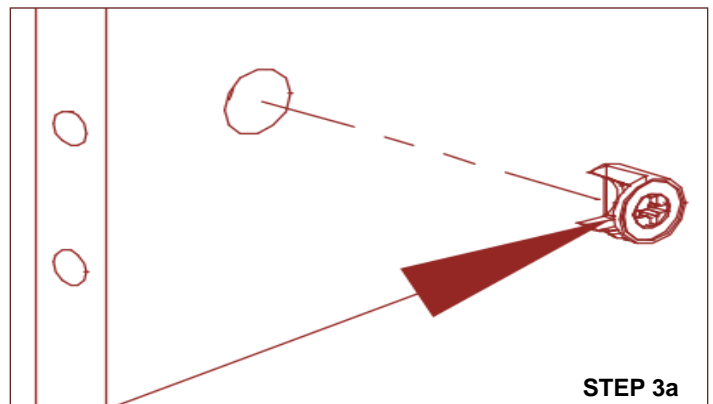
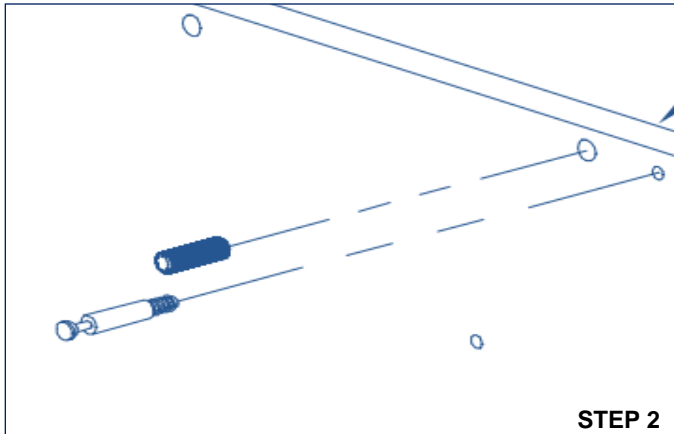

STEP 3: INSERT CAM-LOCKS TO TOP, BOTTOM AND BACK PANEL

Insert 6 cams (Item 10) in the holes provided on the Back Panel (item 3). Insert 6 Cams each in the holes provided on top Interior Panel (Item 4) and Bottom panel (Item 5) and.

Place the Back panel and Bottom panel (which are fastened with each other and with Toe-kick panel) at right angles on the Left (or Right) End panel (Items 1 OR 2) and place the Top panel on the End Panel so that the Dowels and Bolts are inserted into the pre-drilled holes on the edge of the panels.

Twist-lock all the 9 cams with a Philips screw-driver to the Connecting bolts on the end panels.

Now take the opposite End-Panel (left or right), place it on the assembly so that the Dowels and Bolts are inserted into the pre-drilled holes on the edge of the panels and twist-lock the cams into the Connecting Bolts on the End Panel.

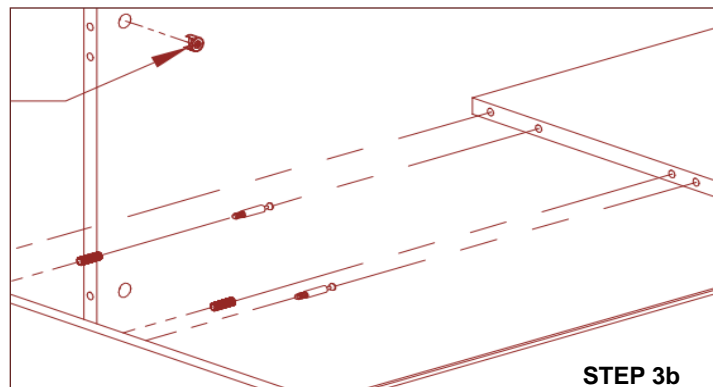

STEP 4: INSERT DRAWERS IN THE ASSEMBLED PRODUCT

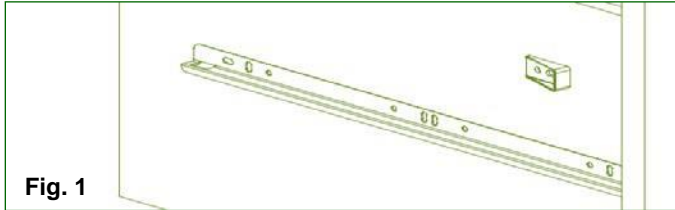

Fig. 1

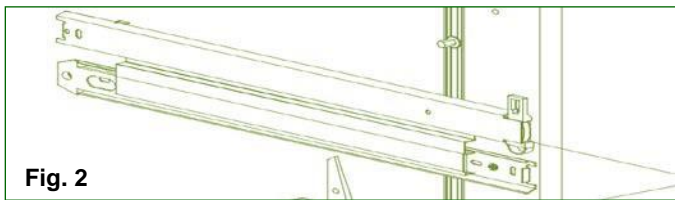
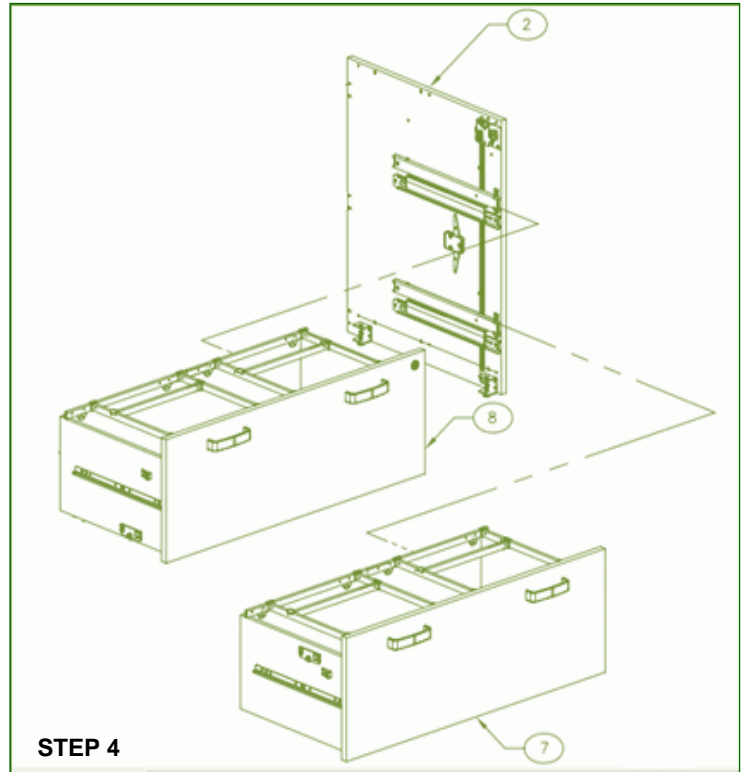

Fig. 2

Locate the Glides as shown in Figure 1 above on the Drawer Assembly (Items 7 and 8). Locate the Glide-Insert as shown in Figure 2 above on the End Panels (items 1 and 2 of the currently assembled product).

Carefully, insert the Drawer Assembly by placing the glide on the rollers of the glide-insert in the End Panel as shown in right Figure (STEP 4). The drawer assembly with lock (Item 8) should be inserted on the top and the drawer without the lock (Item 7) should be inserted at the bottom.



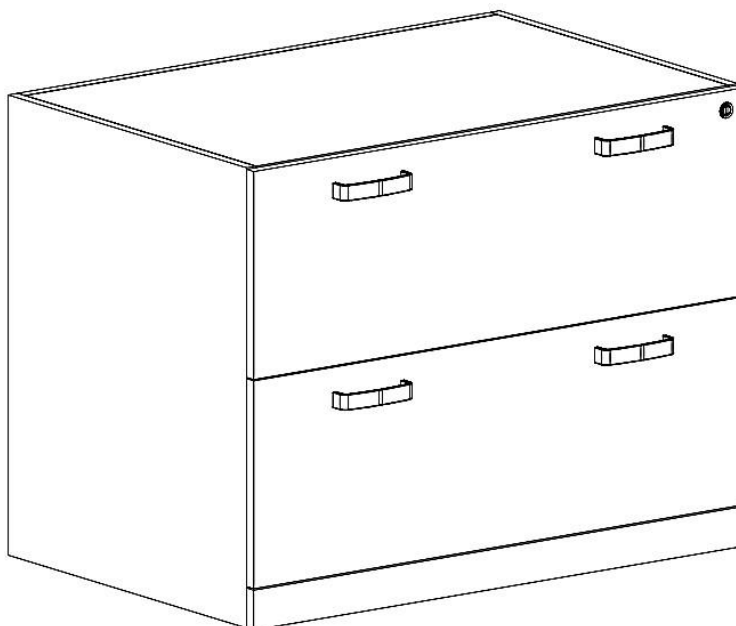

STEP 4

Your Finished Product Should Look like below.







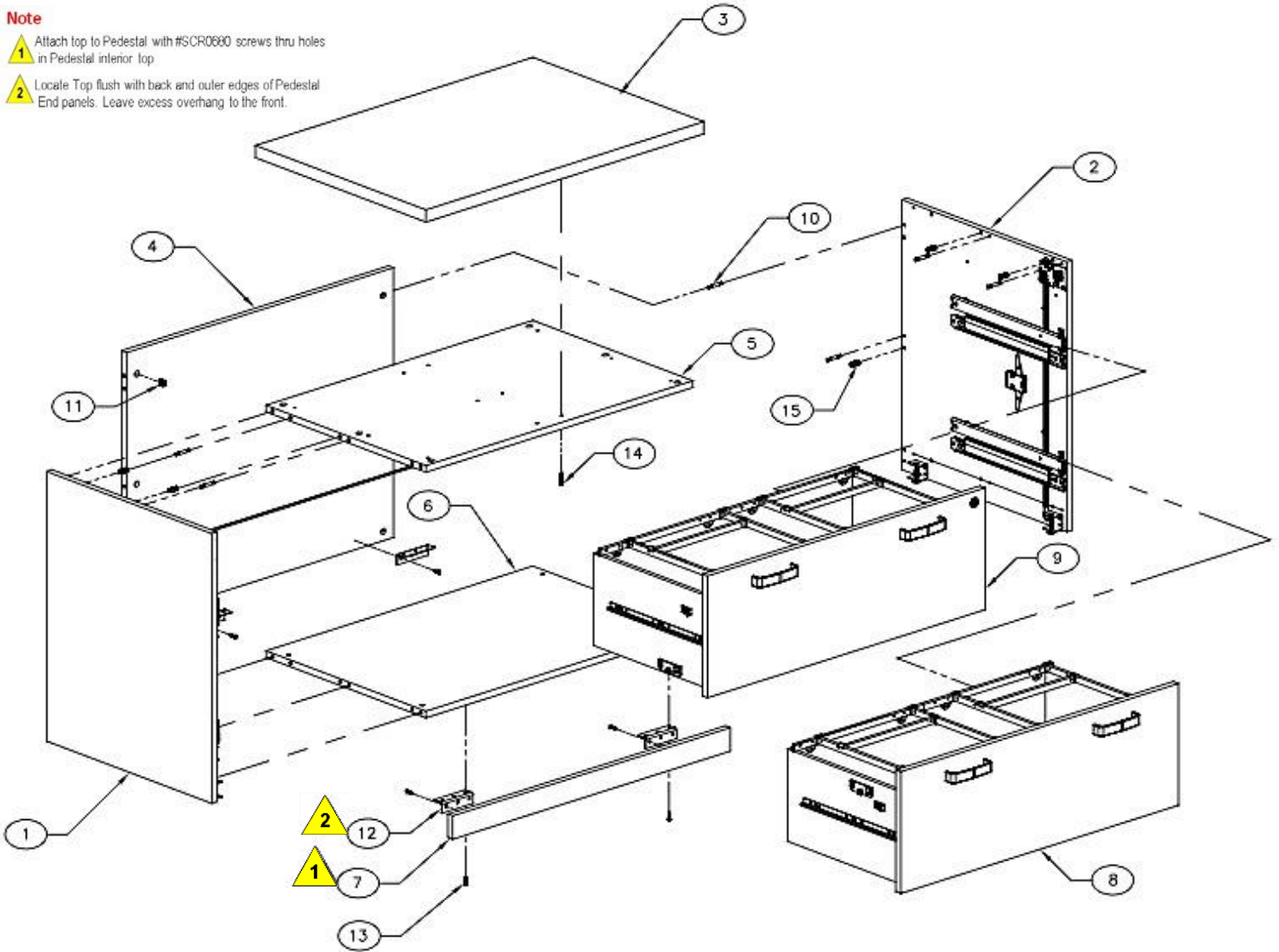

Integrate Assembly Instructions
Lateral File 2 Drawer
(Part No. I2LFS)

Note

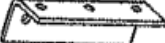
-  Attach top to Pedestal with #SCR0600 screws thru holes in Pedestal interior top
-  Locate Top flush with back and outer edges of Pedestal End panels. Leave excess overhang to the front.



Item #	Part #	Description	Quantity	Item #	Part #	Description	Quantity
1	ISA40013	Subassembly End Panel Left	1	10	CTR21504	Bolts 	18
2	ISA40017	Subassembly End Panel Right	1	11	CTR21541	Cam Locks 	18
3	ISA40045	Top Panel	1	12	BRB0441	Steel Cleats 	4
4	ISA40047	Back Panel	1	13	SCR2507	Screw 5/8 Inch 	24
5	ISA40051	Top Interior Panel	1	14	SCR0677	Screw 1-1/4 Inch 	12
6	ISA40055	Bottom Panel	1	15	DWL0027	Dowel 1 Inch 	18
7	ISA40057	Toe Kick Panel	1				
8	ISA130027	Drawer Assembly	1				
9	ISA130029	Drawer Assembly with lock	1				

Integrate Assembly Instructions
Lateral File 2 Drawer
(Part No. I2LFS)

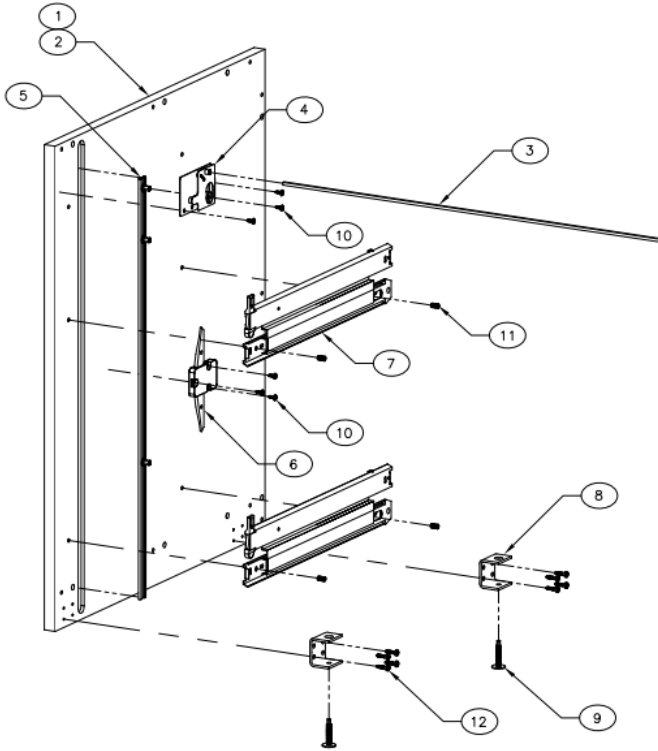

Item #	Part #	Description	Quantity
1	ISA40029	Hardware Location	1
2	ISA40037	End Panel Left*	1
3	LOX0119	Shaft 36"	1
4	LOX0121	Remote Actuator	1
5	LOX0122	Lock Bar	1
6	HWS2017	Anti-Tip-Snapper	1
7	DRS0002L	16" Drawer Slide Left	2
8	GLI0301	Zinc Plated Gusset	2
9	GLI0211	Hex Tip Leveler	2
10	SCR9404	7/16 Sheet metal Screw	9
11	SCR2060	Screw 5mm Dia.	6
12	SCR2507	5/8 Screw	8

*The End Panel Right (ISA40017) drawing excludes 36" Shaft (Item 3) and replaces Drive Actuator (LOX0114) in Item 4

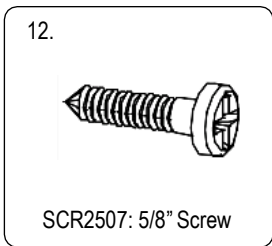
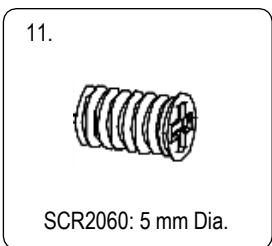
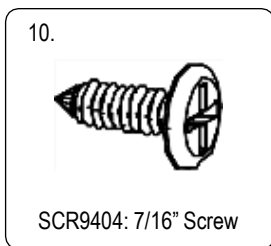
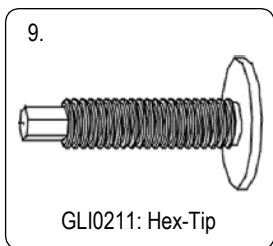
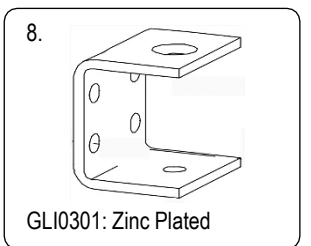
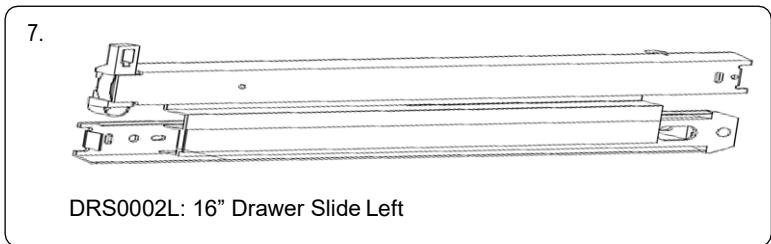
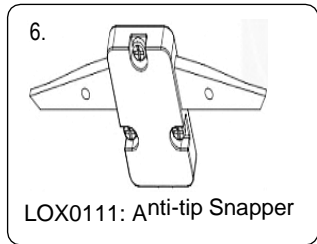
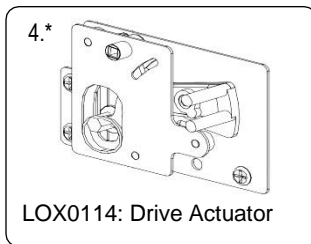
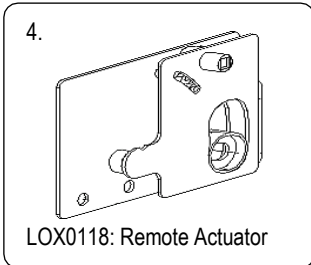

Integrate Assembly Instructions
Lateral File 2 Drawer
(Part No. I2LFS)

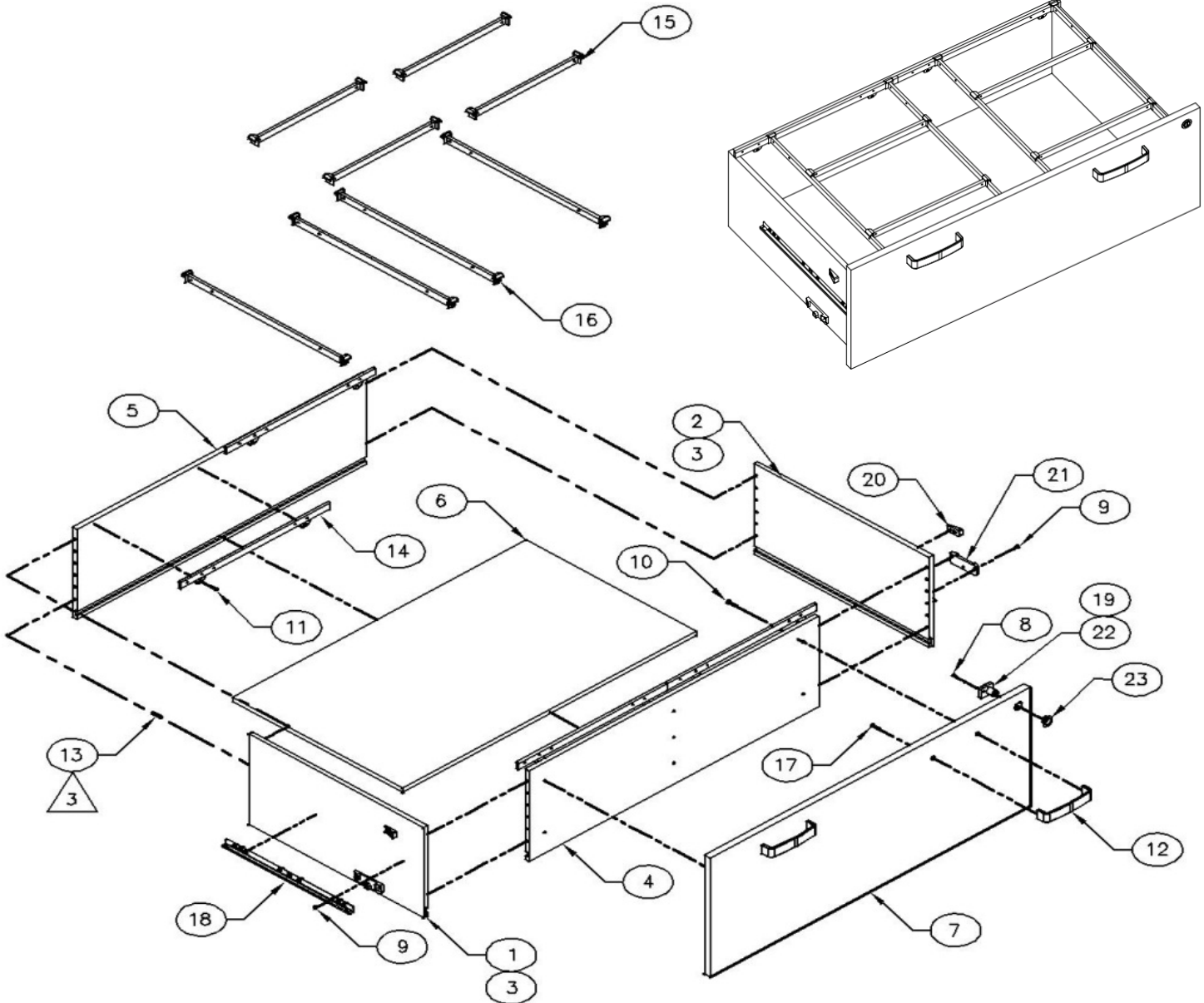

Item #	Part #	Description	Quantity
1	ISA130071	Hardware Location Left	1
2	ISA130073	Hardware Location Right	1
3	ISA130083	Lateral File Drawer Side	2
4	ISA130093	Lateral File Drawer Front	1
5	ISA1300103	Lateral File Drawer Back	1
6	ISA1300107	Lateral File Drawer Bottom	1
7	ISA1300121	Lateral File Drawer Face w/lock*	1

* The Drawer Assembly without lock (ISA40027) drawing excludes lock parts in Items 8,19,22 & 23 and replaces Drawer Face with ISA1300119.

Cont...

Integrate Assembly Instructions
Lateral File 2 Drawer
(Part No. I2LFS)

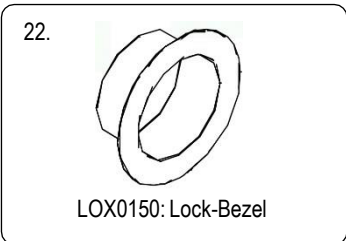
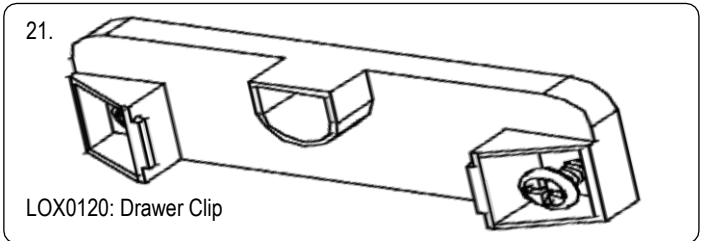
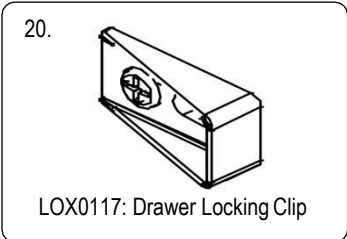
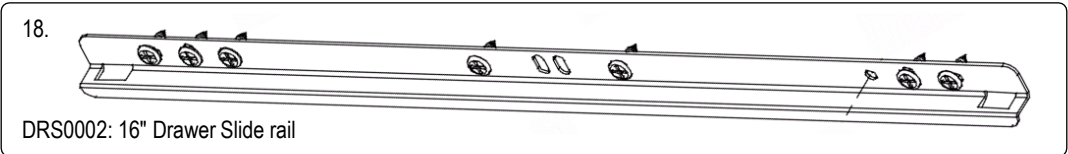
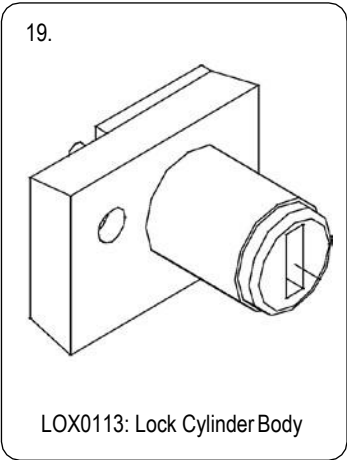
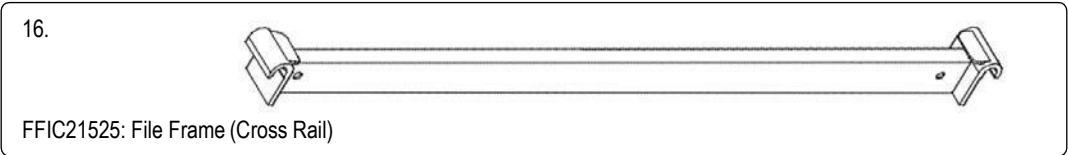
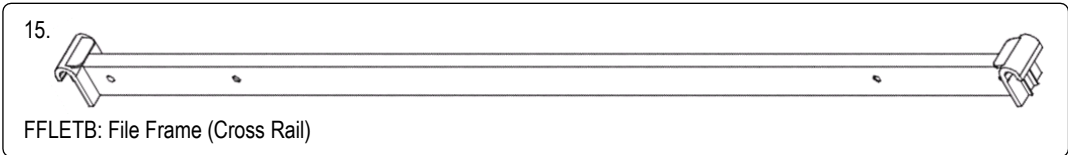
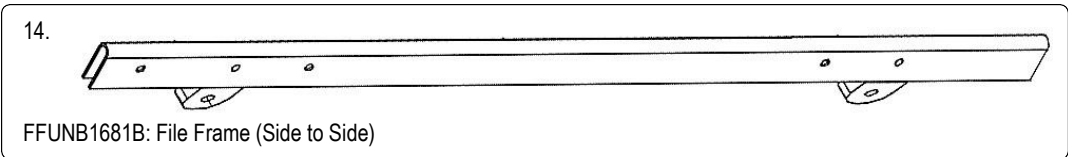
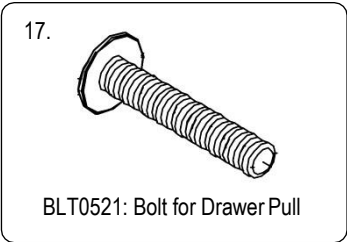
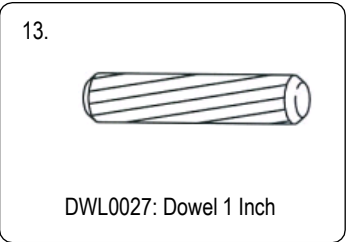
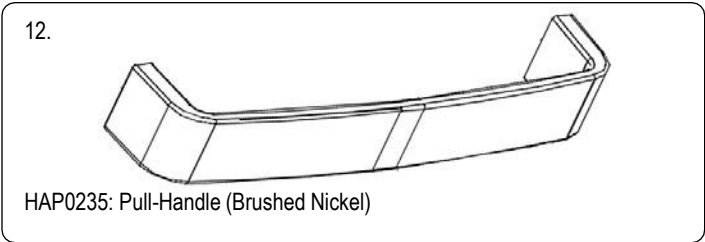
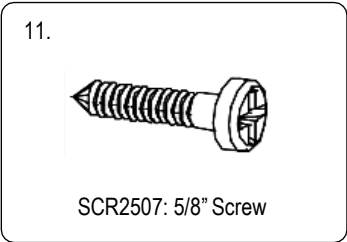
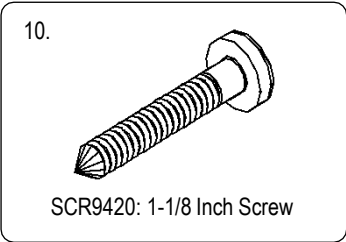

Integrate Assembly Instructions
Lateral File 2 Drawer
(Part No. I2LFS)

Your Final Assembled Product should look like below (Based on the Ordered Configuration)

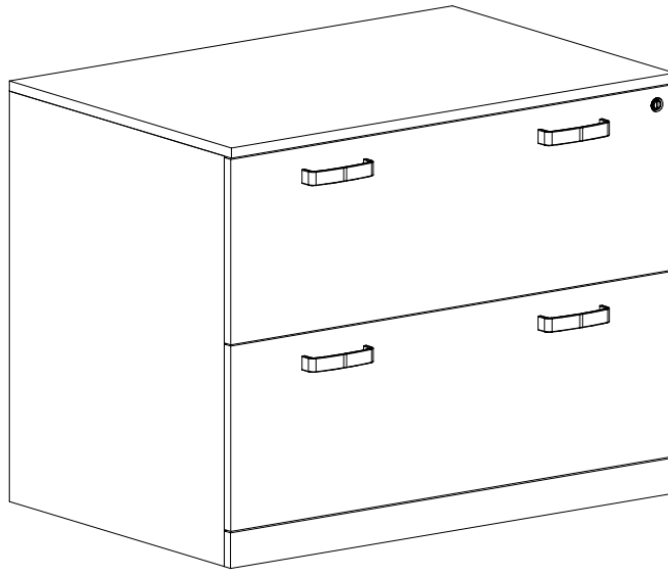

Lateral File 2 Drawer Stand-Alone Configuration

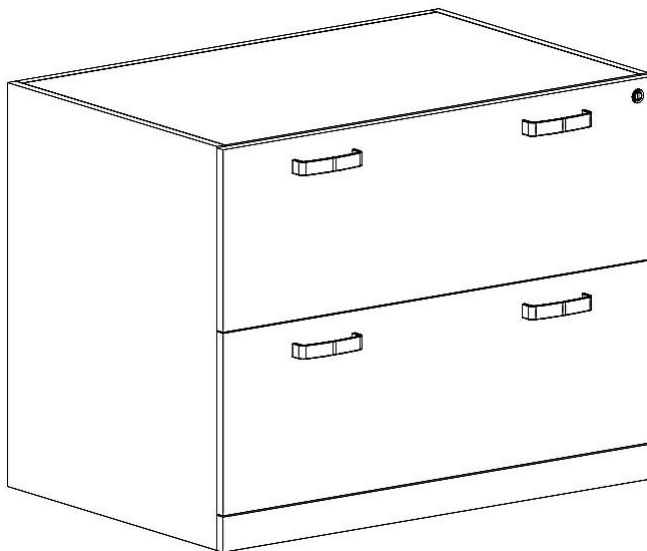

Lateral File 2 Drawer WorkSurface Supporting Configuration





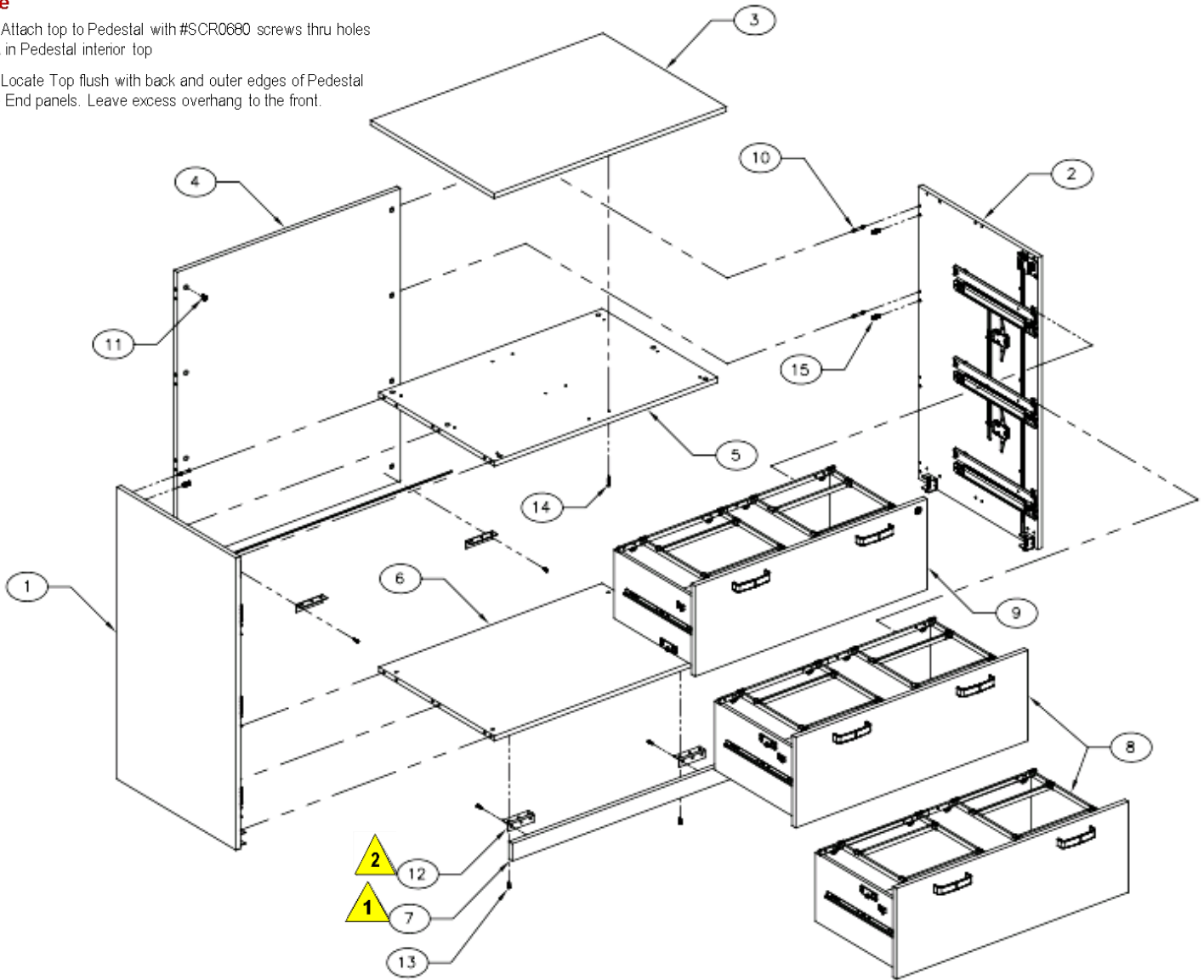

Integrate Assembly Instructions
Lateral File 3 Drawer
(Part No. I3LFS)

Note

- 1** Attach top to Pedestal with #SCR0680 screws thru holes in Pedestal interior top
- 2** Locate Top flush with back and outer edges of Pedestal End panels. Leave excess overhang to the front.



Item #	Part #	Description	Quantity
1	ISA40021	Subassembly End Panel Left	1
2	ISA40025	Subassembly End Panel Right	1
3	ISA40045	Top Panel	1
4	ISA40049	Back Panel	1
5	ISA40051	Top Interior Panel	1
6	ISA40055	Bottom Panel	1
7	ISA40057	Toe Kick Panel	1
8	ISA130027	Drawer Assembly	2
9	ISA130029	Drawer Assembly with lock	1

Item #	Part #	Description	Quantity
10	CTR21504	Bolts 	20
11	CTR21541	Cam Locks 	20
12	BRB04411	Steel Cleats 	4
13	SCR2507	Screw 5/8 Inch 	24
14	SCR0677	Screw 1-1/4 Inch 	12
15	DWL0027	Dowel 1 Inch 	20

Integrate Assembly Instructions
Lateral File 3 Drawer

(Part No. I3LFS)

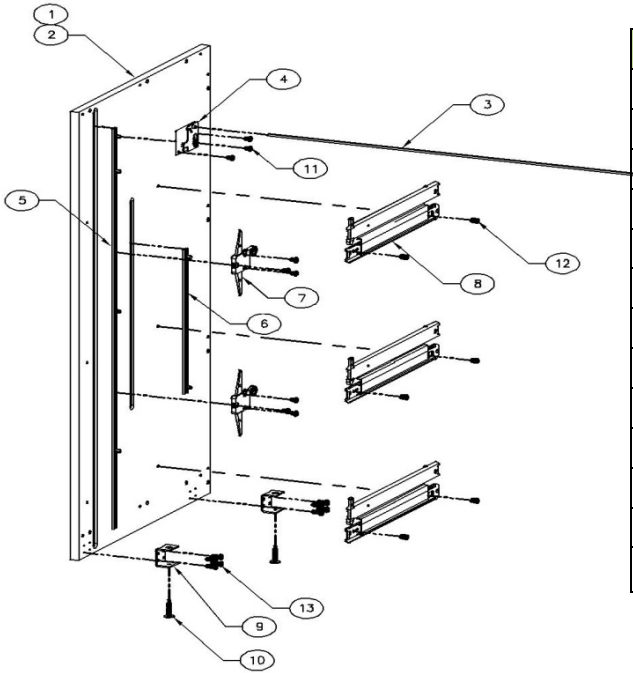

Item #	Part #	Description	Quantity
1	ISA40033	Hardware Location	1
2	ISA40041	End Panel Left*	1
3	LOX0119	Shaft 36"	1
4	LOX0118	Remote Actuator	1
5	LOX0127	Central Lock	1
6	LOX0122	Lock bar	1
7	LOX0111	Anti-Tip-Snapper	2
8	DRS0002L	16" Drawer Slide Left	3
9	GLI0301	Zinc Plated Gusset	2
10	GLI0211	Hex Tip Leveler	2
11	SCR9404	7/16 Sheet metal Screw	9
12	SCR2060	Screw 5mm Dia.	6
13	SCR2507	5/8 Screw	8

* The End Panel Right (ISA40025) drawing excludes 36" Shaft (Item 3) and replaces Drive Actuator (LOX0114) in Item 4

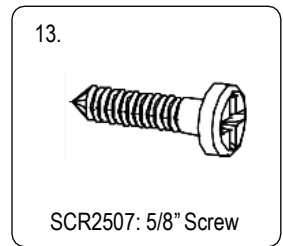
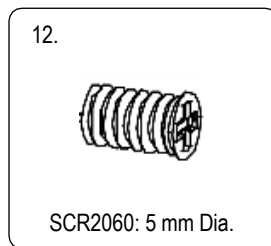
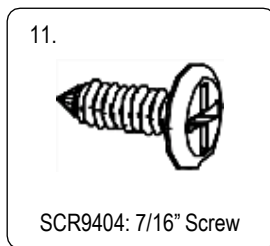
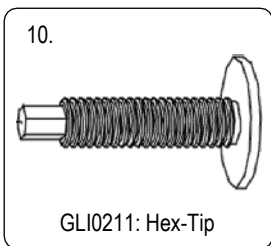
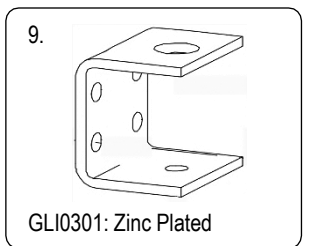
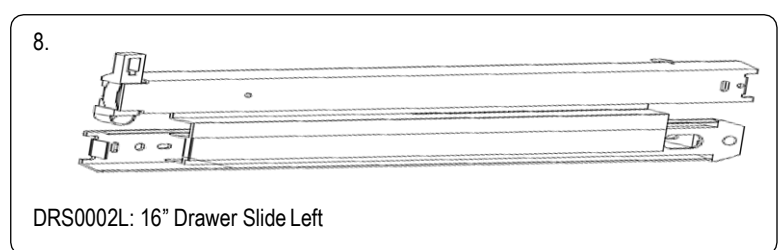
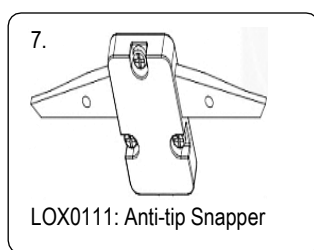
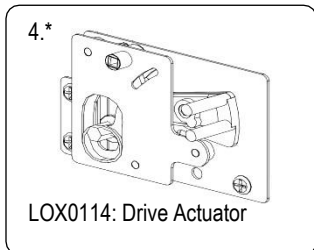
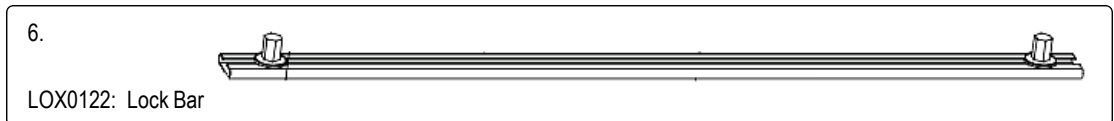
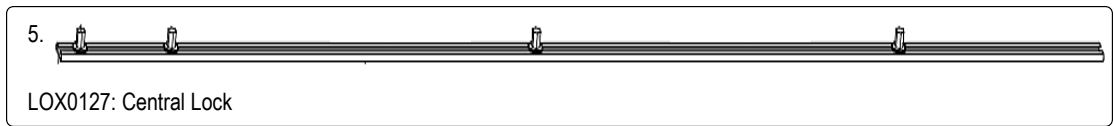
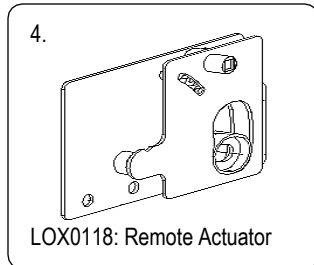

Integrate Assembly Instructions
Lateral File 3 Drawer
(Part No. I3LFS)

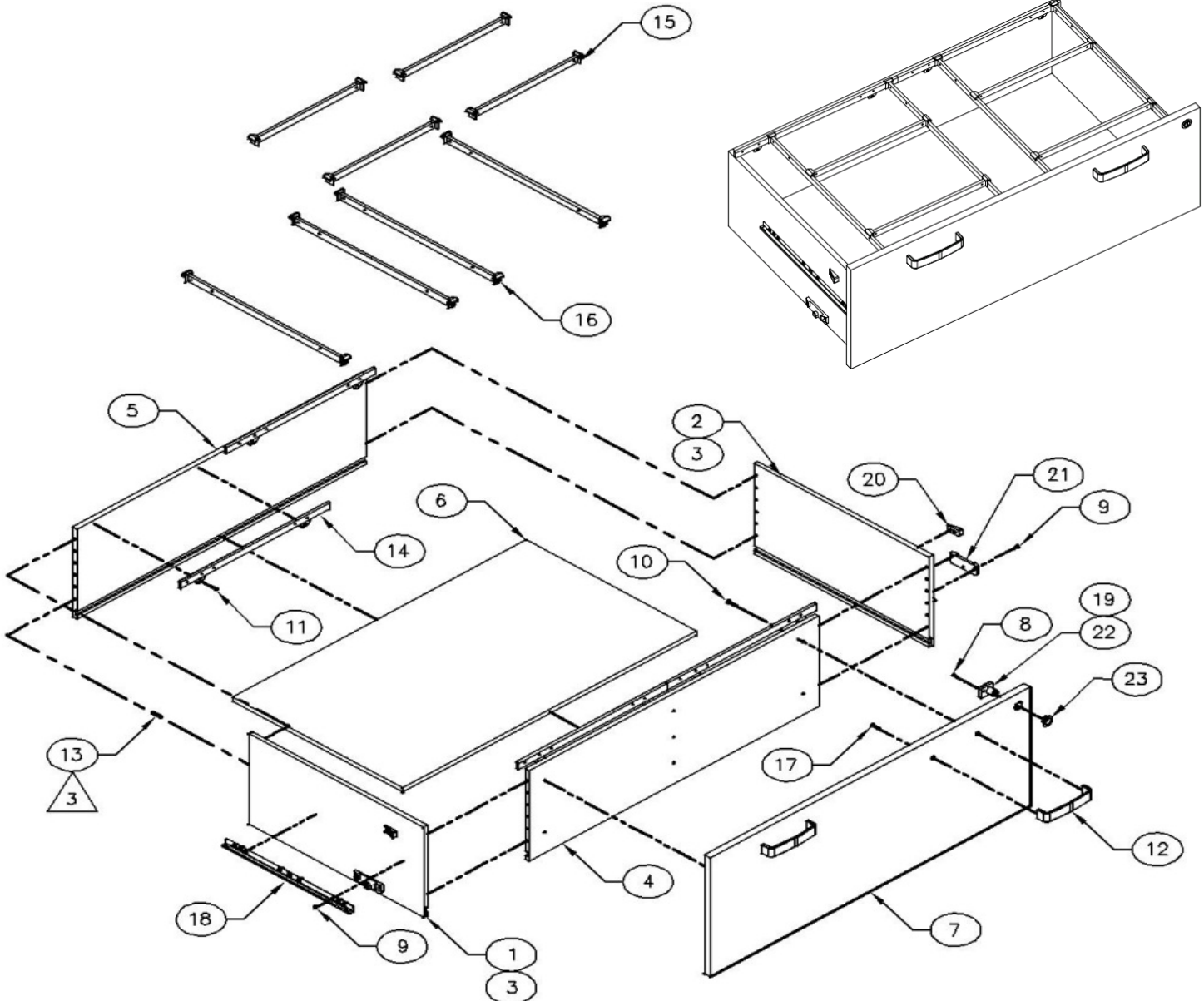

Item #	Part #	Description	Quantity
1	ISA130071	Hardware Location Left	1
2	ISA130073	Hardware Location Right	1
3	ISA130083	Lateral File Drawer Side	2
4	ISA130093	Lateral File Drawer Front	1
5	ISA1300103	Lateral File Drawer Back	1
6	ISA1300107	Lateral File Drawer Bottom	1
7	ISA1300121	Lateral File Drawer Face w/lock*	1

* The Drawer Assembly without lock (ISA40027) drawing excludes lock parts in Items 8,19,22 & 23 and replaces Drawer Face with ISA1300119.

Cont...

8.



SCR2507: 5/8 Inch Screw

9.



SCR9404: 7/16" Screw

10.

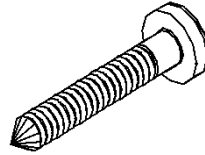

SCR9420: 1-1/8 Inch Screw

11.



SCR2507: 5/8" Screw

12.

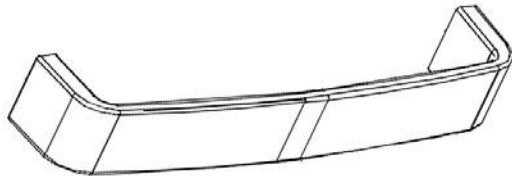

HAP0235: Pull-Handle (Brushed Nickel)

13.



DWL0027: Dowel 1 Inch

17.

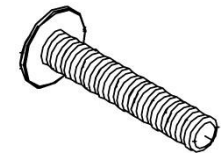

BLT0521: Bolt for Drawer Pull

14.

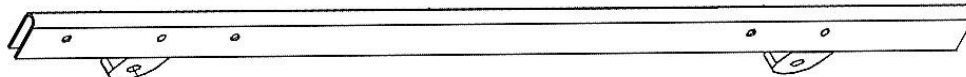

FFUNB1681B: File Frame (Side to Side)

15.

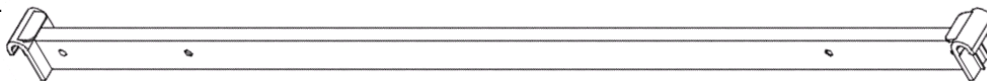

FFLETB: File Frame (Cross Rail)

16.

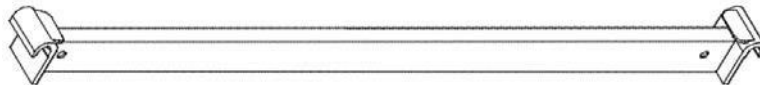

FFIC21525: File Frame (Cross Rail)

18.

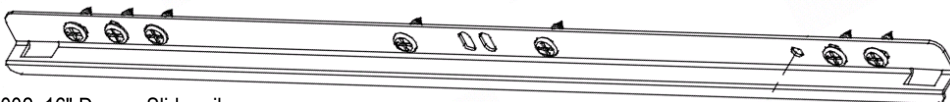

DRS0002: 16" Drawer Slide rail

19.

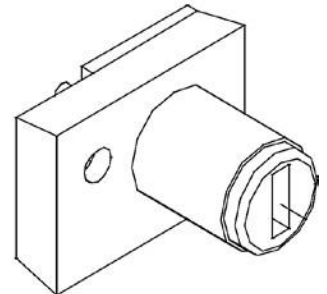

LOX0113: Lock Cylinder Body

20.

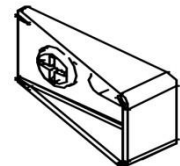

LOX0117: Drawer Locking Clip

21.

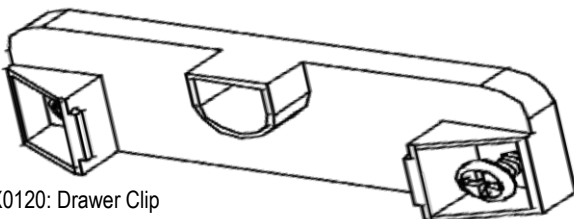

LOX0120: Drawer Clip

22.

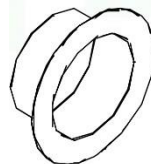

LOX0150: Lock-Bezel

Integrate Assembly Instructions
Lateral File 3 Drawer
(Part No. I3LFS)

Your Final Assembled Product should look like below (Based on the Ordered Configuration)

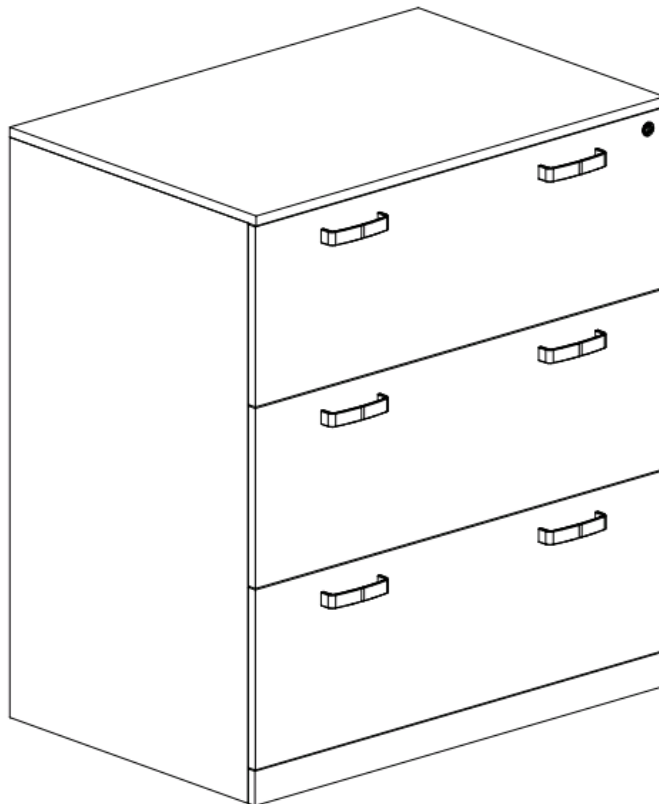

Integrate Assembly Instructions
Over Head Full Back 60" 4 Door
(Part No. I60OHCFB)

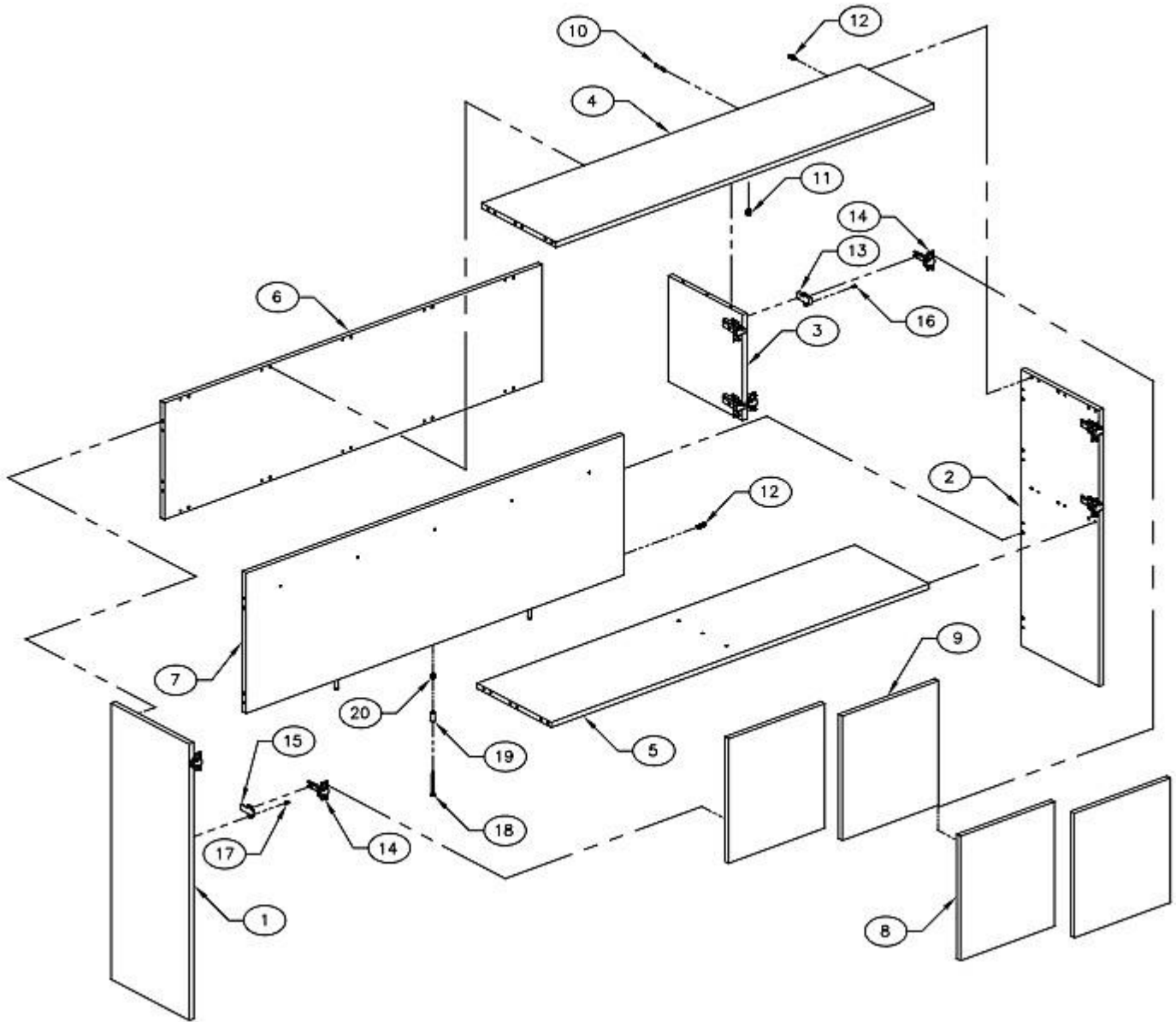

1	ISA90009	Left End Panel	1
2	ISA90011	Right End Panel	1
3	ISA90013	Divider Panel	1
4	ISA90017	Top Panel	1
5	ISA90021	Shelf Panel	1
6	ISA90025	Back Panel, Upper	1
7	ISA90029	Back Panel, Lower	1
8	ISA90033	Door Panel, Left Hinge	2
9	ISA90037	Door Panel, Right Hinge	2

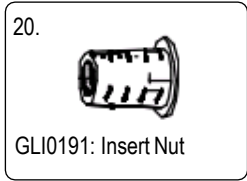
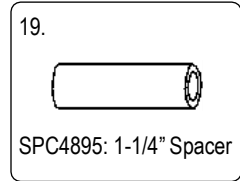
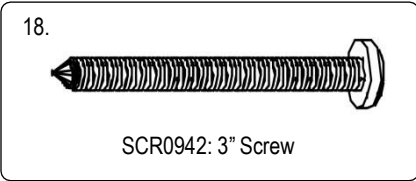
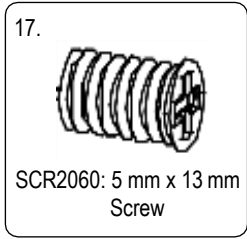
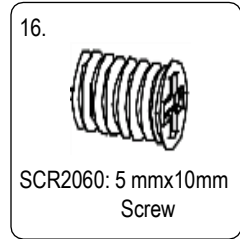
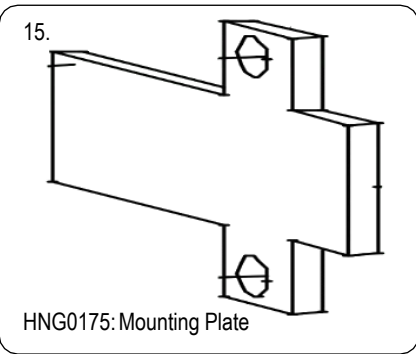
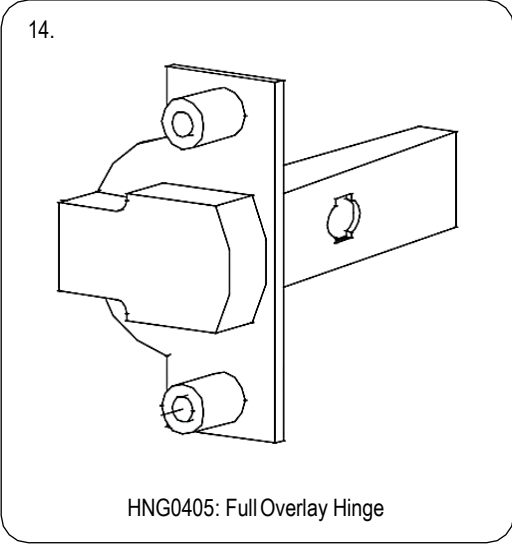
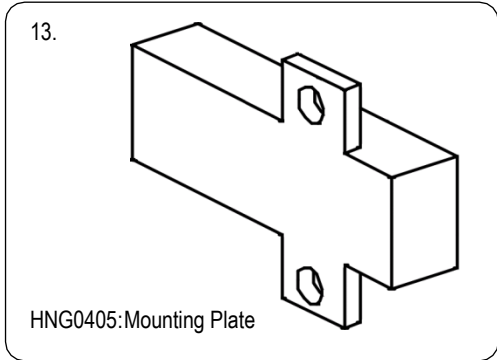
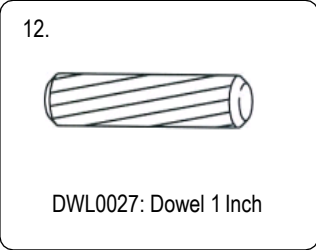
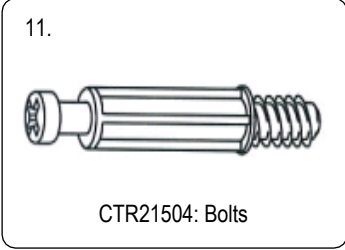
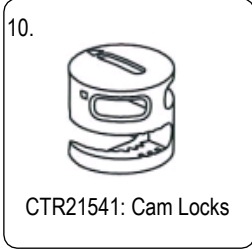

Your Final Assembled Product should look like below

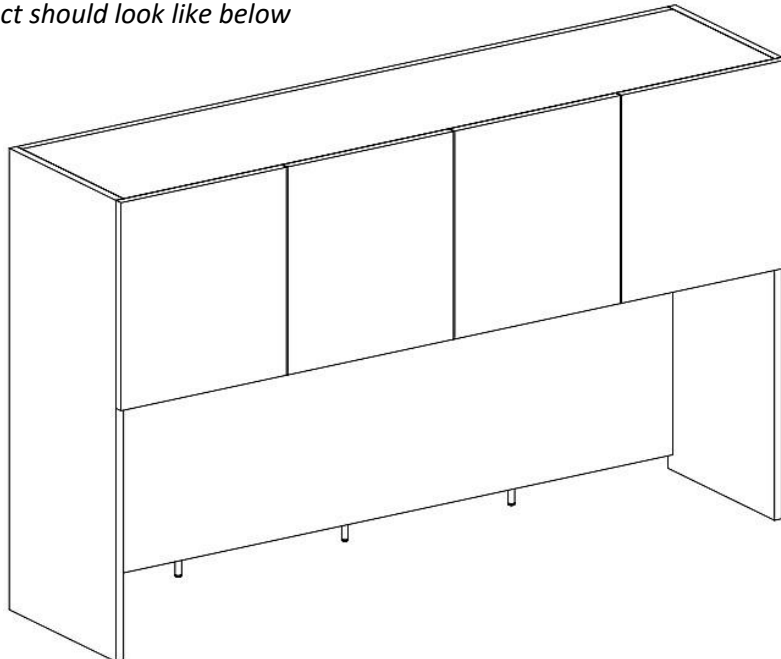

Integrate Assembly Instructions
Over Head Full Back 72" 4 Door
(Part No. I72OHCFB)

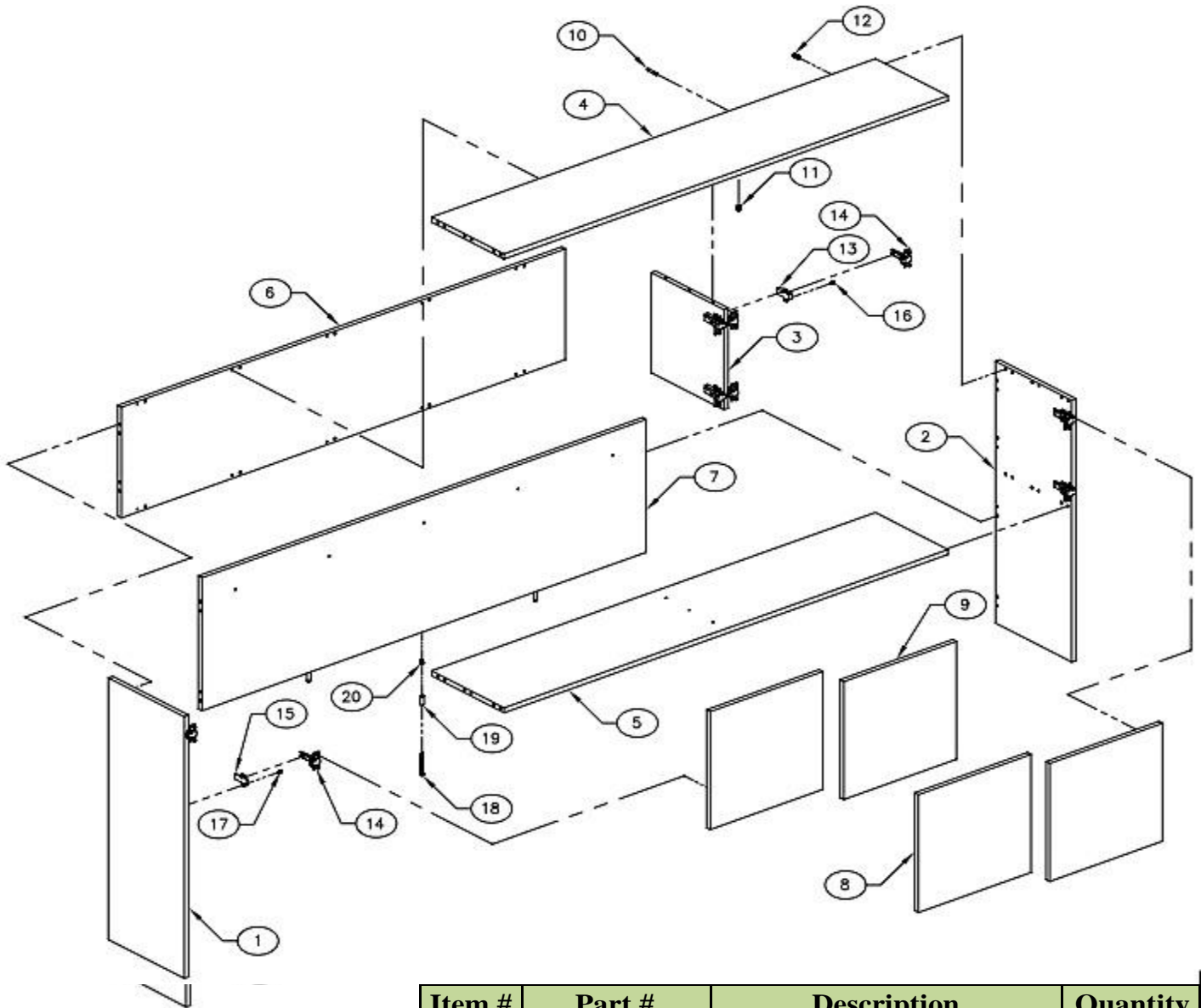

Item #	Part #	Description	Quantity
1	ISA90009	Left End Panel	1
2	ISA90011	Right End Panel	1
3	ISA90013	Divider Panel	1
4	ISA90015	Top Panel	1
5	ISA90019	Shelf Panel	1
6	ISA90023	Back Panel, Upper	1
7	ISA90027	Back Panel, Lower	1
8	ISA90031	Door Panel, Left Hinge	2
9	ISA90035	Door Panel, Right Hinge	2

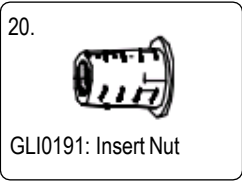
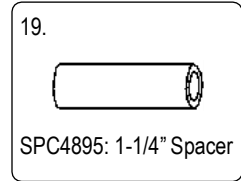
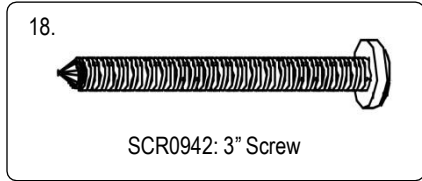
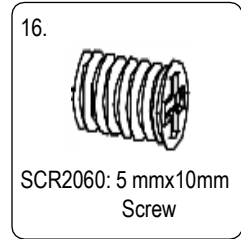
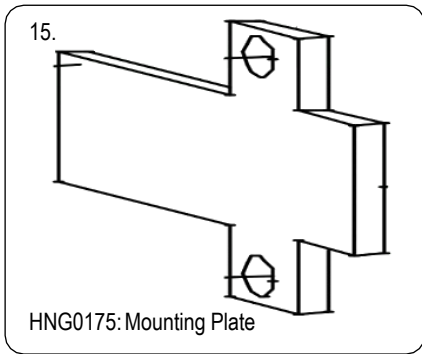
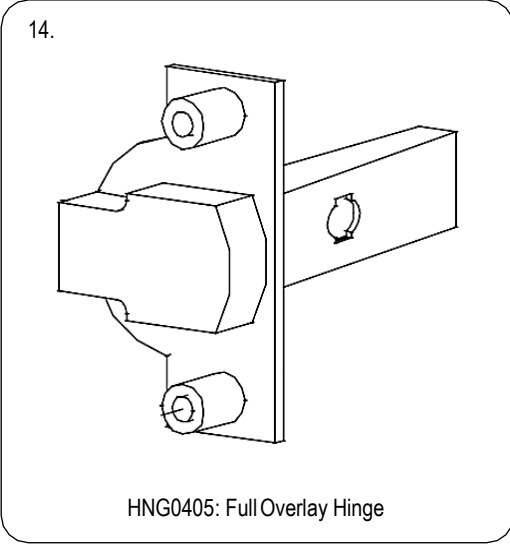
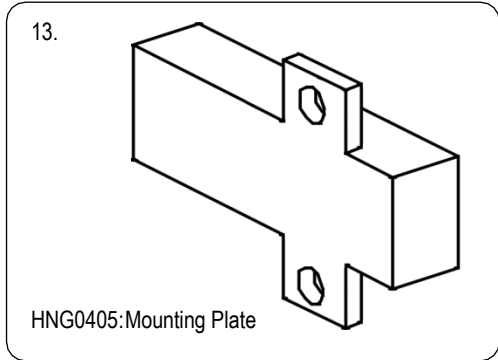
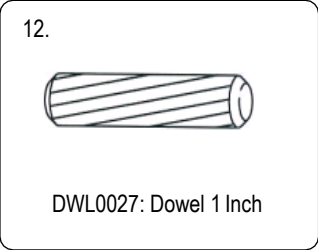
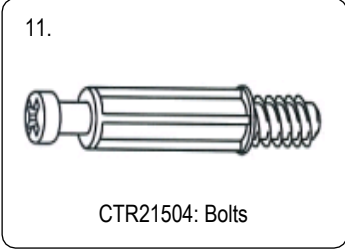
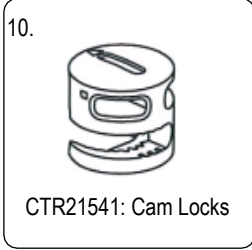

Your Final Assembled Product should look like below

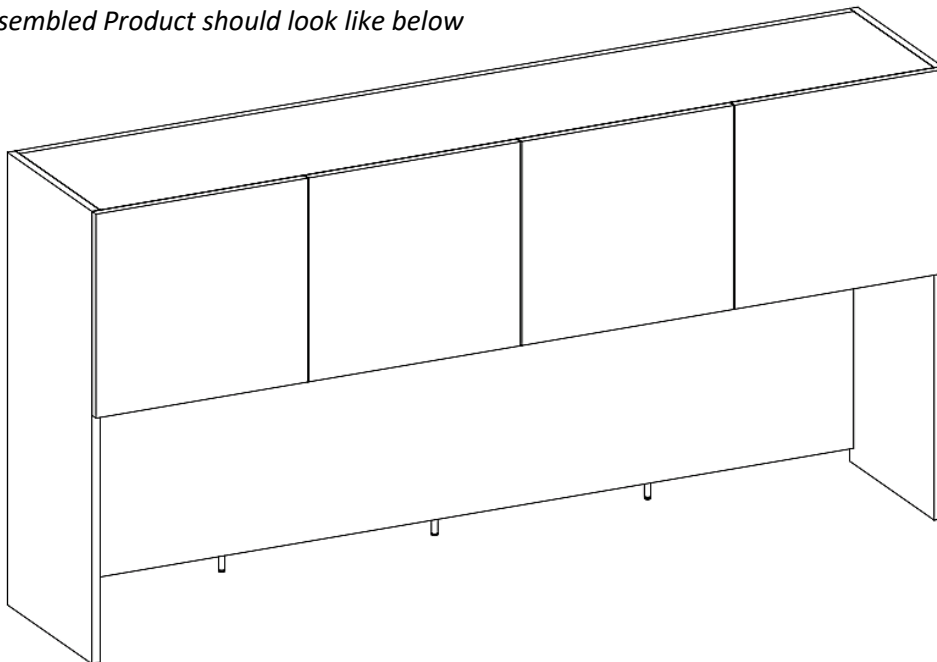

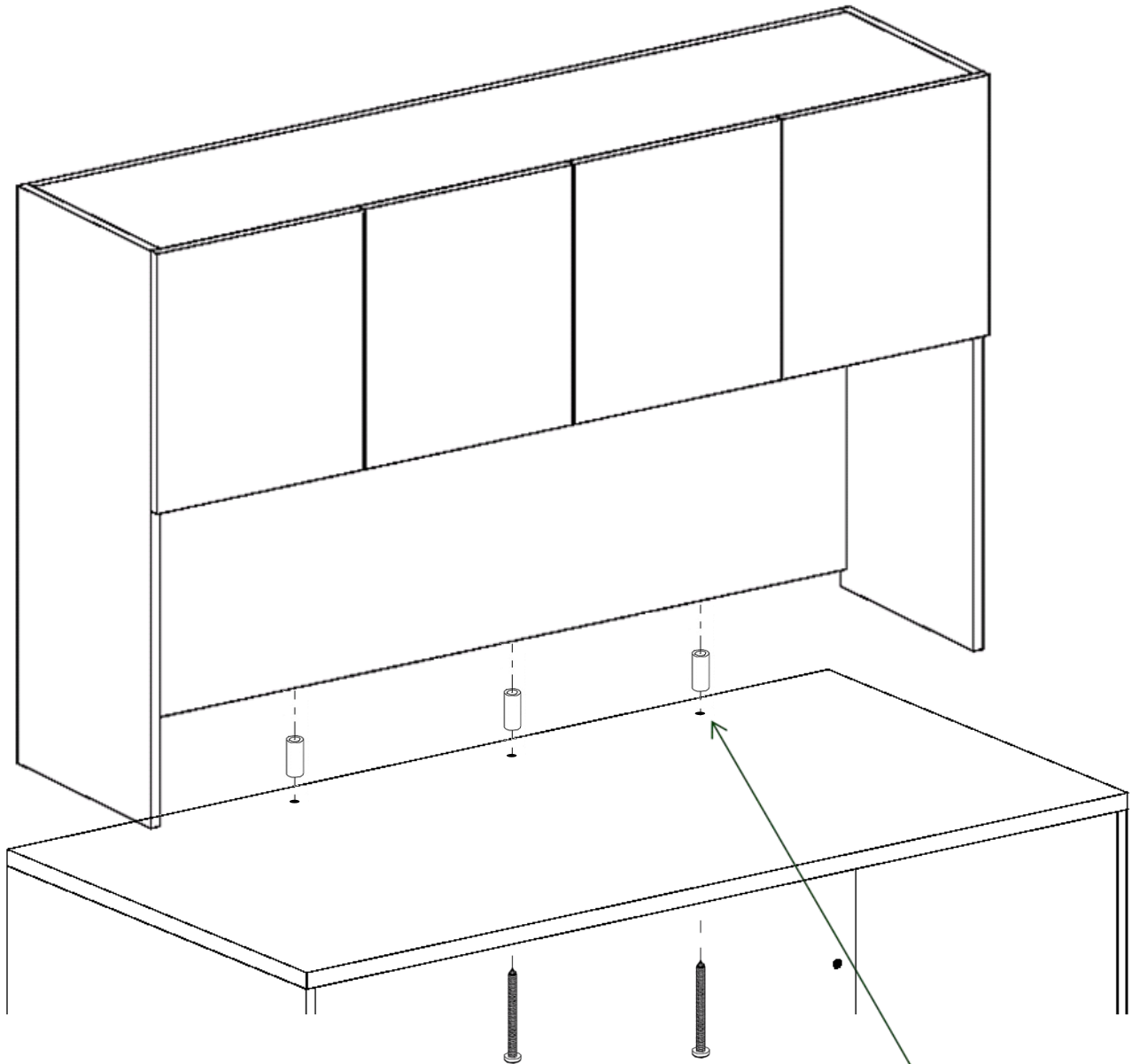

Included Hardware: 3 pieces each of

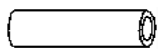

SPC4895: 1-1/4" Spacer



SCR0942: 3" Screw

Locate the pre-drilled Pilot holes on the Worksurface and insert (facing upward) the 3 Inch Screw from underside of the Worksurface. Place the Spacers on the screw above the Worksurface and place the 4-Door Overhead Assembly on the Worksurface. Fasten the screws to the insert nuts located at the bottom edge of the back panel of the Overhead.

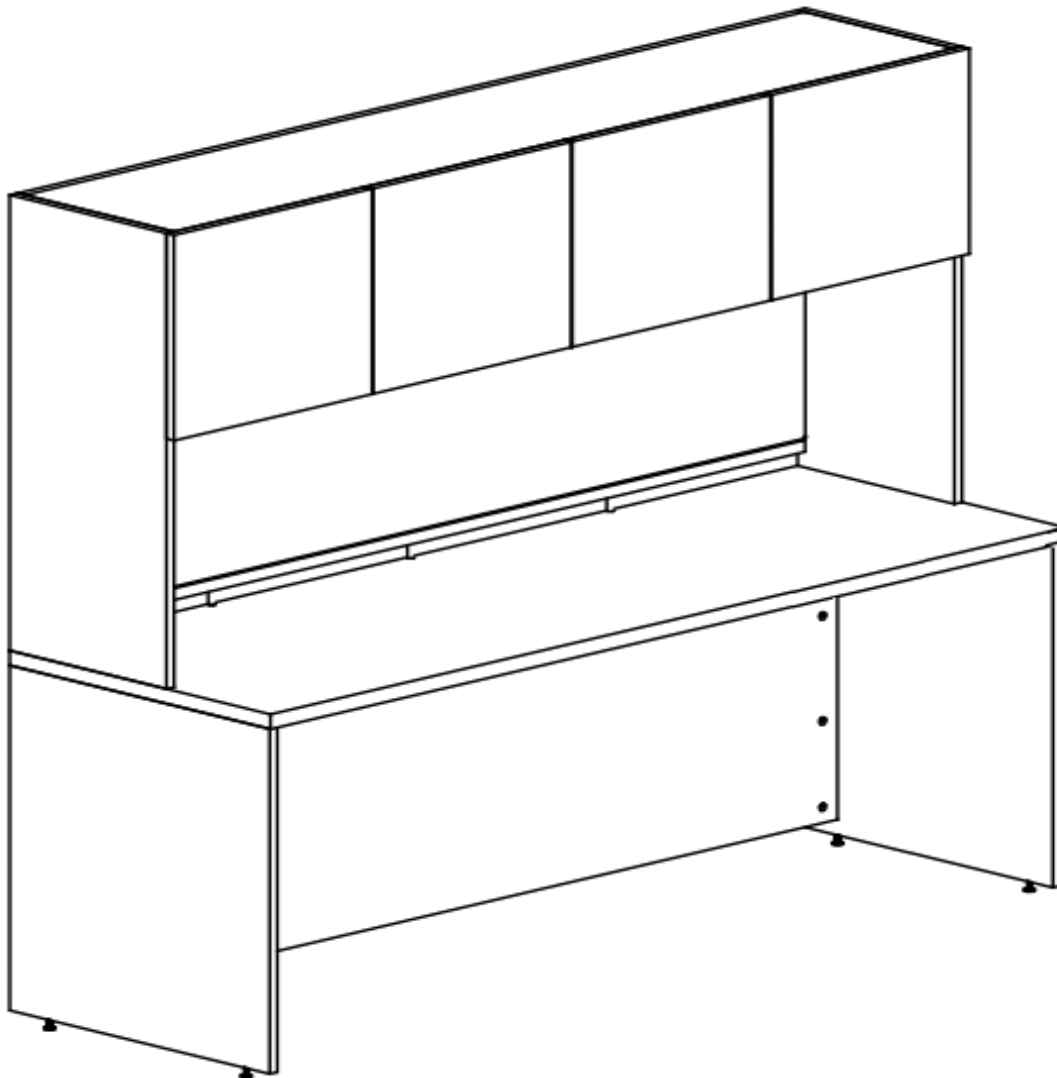

Integrate Assembly Instructions
Over Head Full Back 4-Door
(Part No. I60OHCFB, I72OHCFB)

Your Final Assembled Product should look like below: (Overhead attached to Shell Desk as shown)





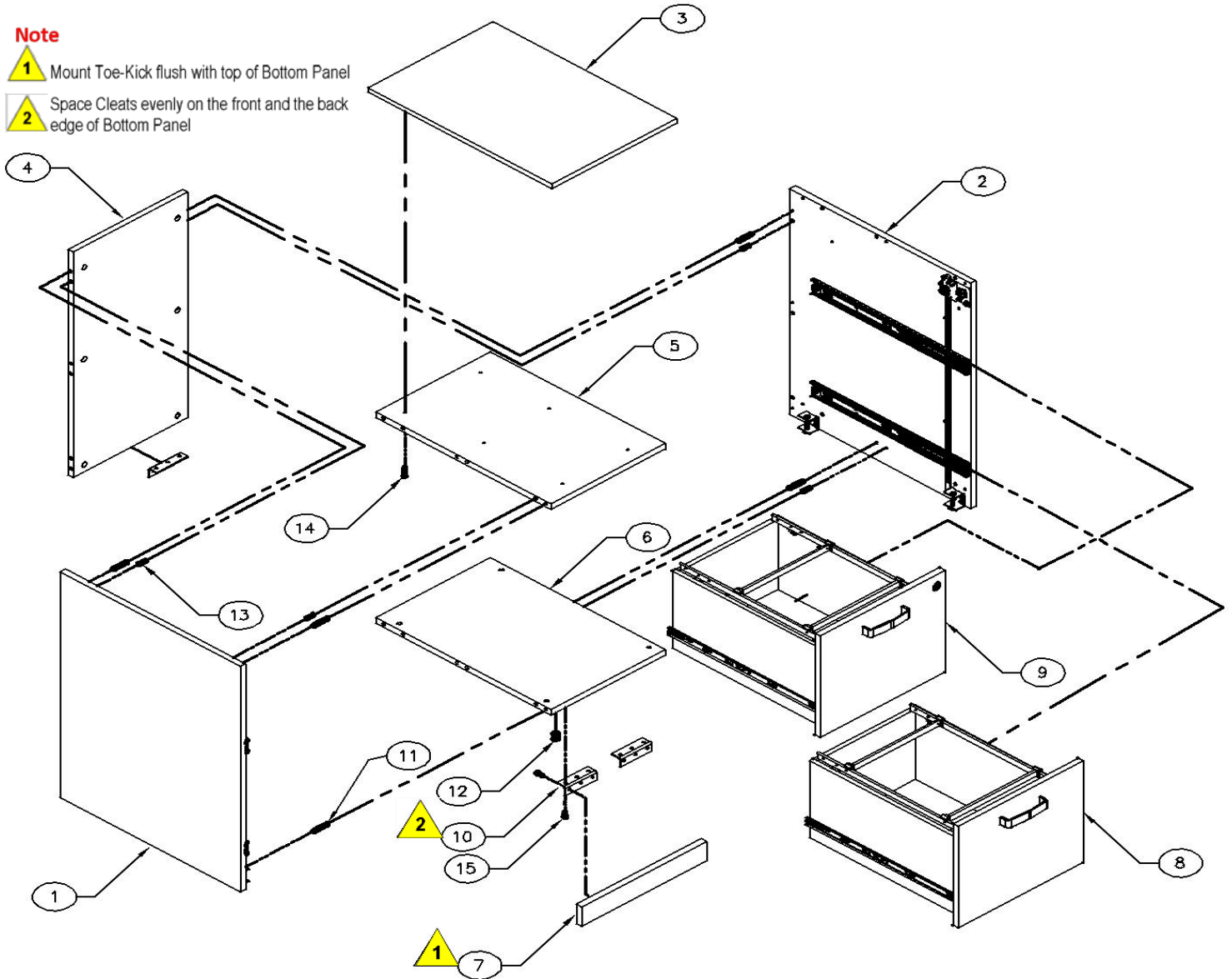

Integrate Assembly Instructions
Pedestal (File/File)
(Part No. I24PD)

Note

-  1 Mount Toe-Kick flush with top of Bottom Panel
-  2 Space Cleats evenly on the front and the back edge of Bottom Panel

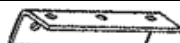
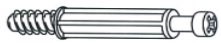

Item #	Part #	Description	Quantity
1	ISA50041	Subassembly End Panel Left	1
2	ISA50045	Subassembly End Panel Right	1
3	ISA50073	Top Panel	1
4	ISA50075	Back Panel	1
5	ISA50077	Top Interior Panel	1
6	ISA50081	Bottom Panel	1
7	ISA50085	Toe Kick Panel	1
8	ISA130015	File Drawer Assembly	1
9	ISA130019	File Drawer Assembly w/ lock	1

Item #	Part #	Description	Quantity
10	BRB0441	Steel Cleats 	3
11	CTR21504	Bolts 	18
12	CTR21541	Cam Locks 	18
13	DWL0027	Dowel 1 Inch 	18
14	SCR0677	Screw 1-1/4 Inch 	6
15	SCR2507	Screw 5/8 Inch 	18

ISA50045: Subassembly End Panel Right

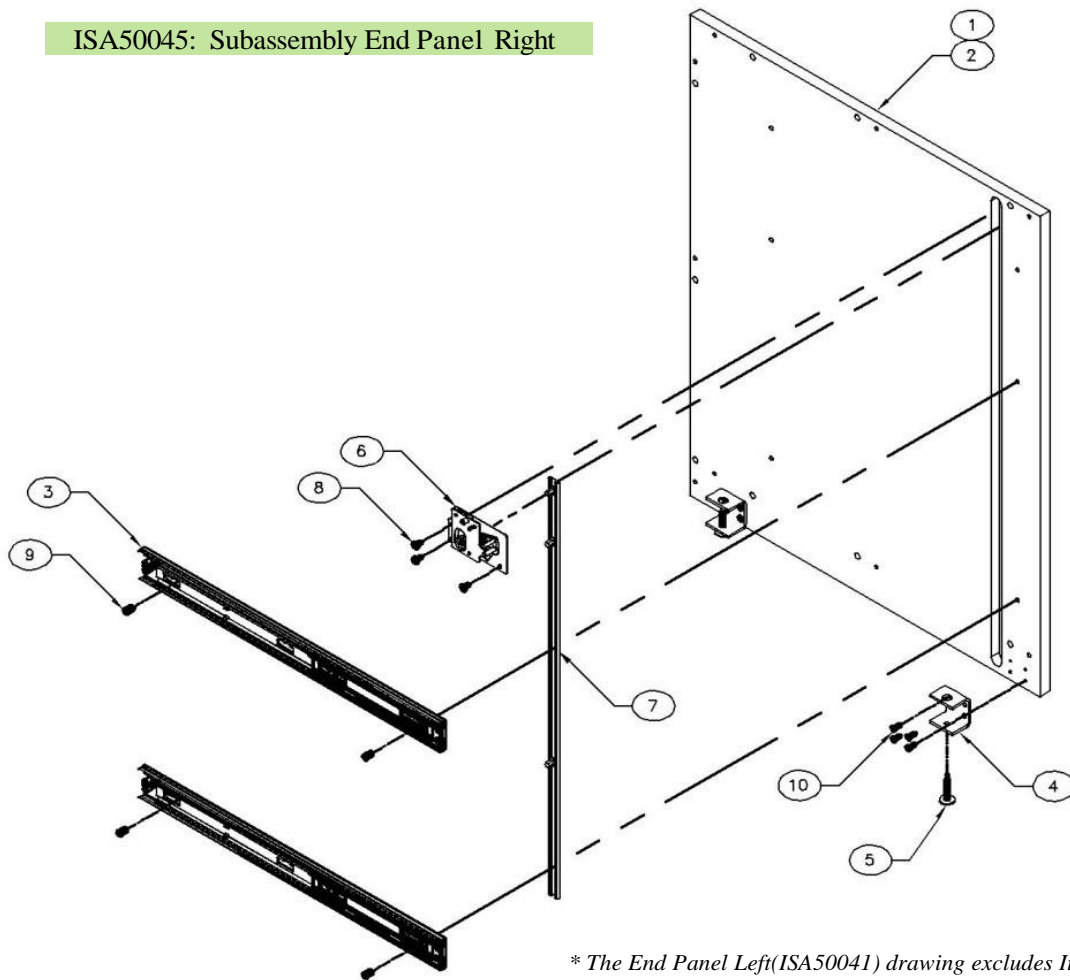

* The End Panel Left(ISA50041) drawing excludes Items 6 through 8.

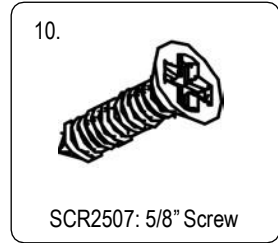
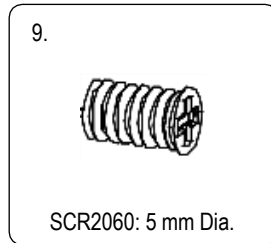
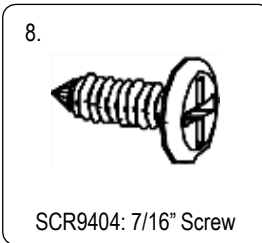
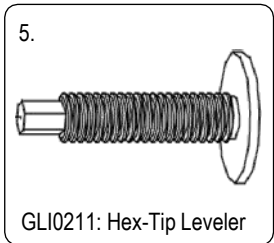
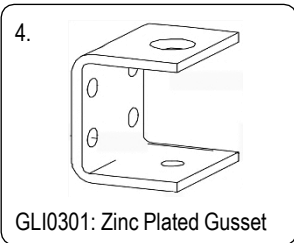
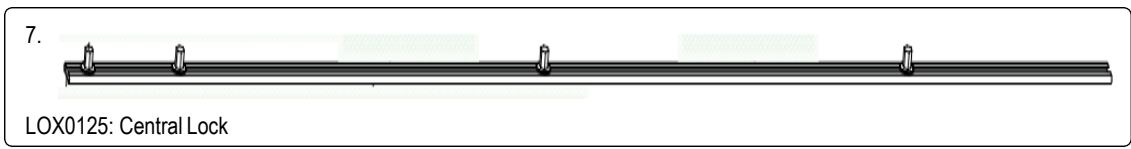
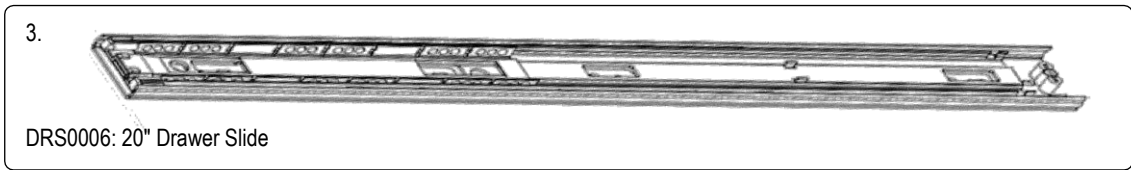
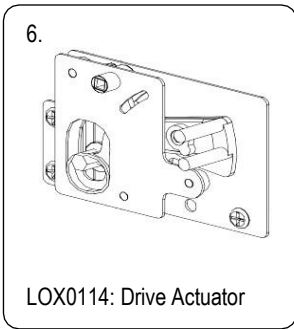

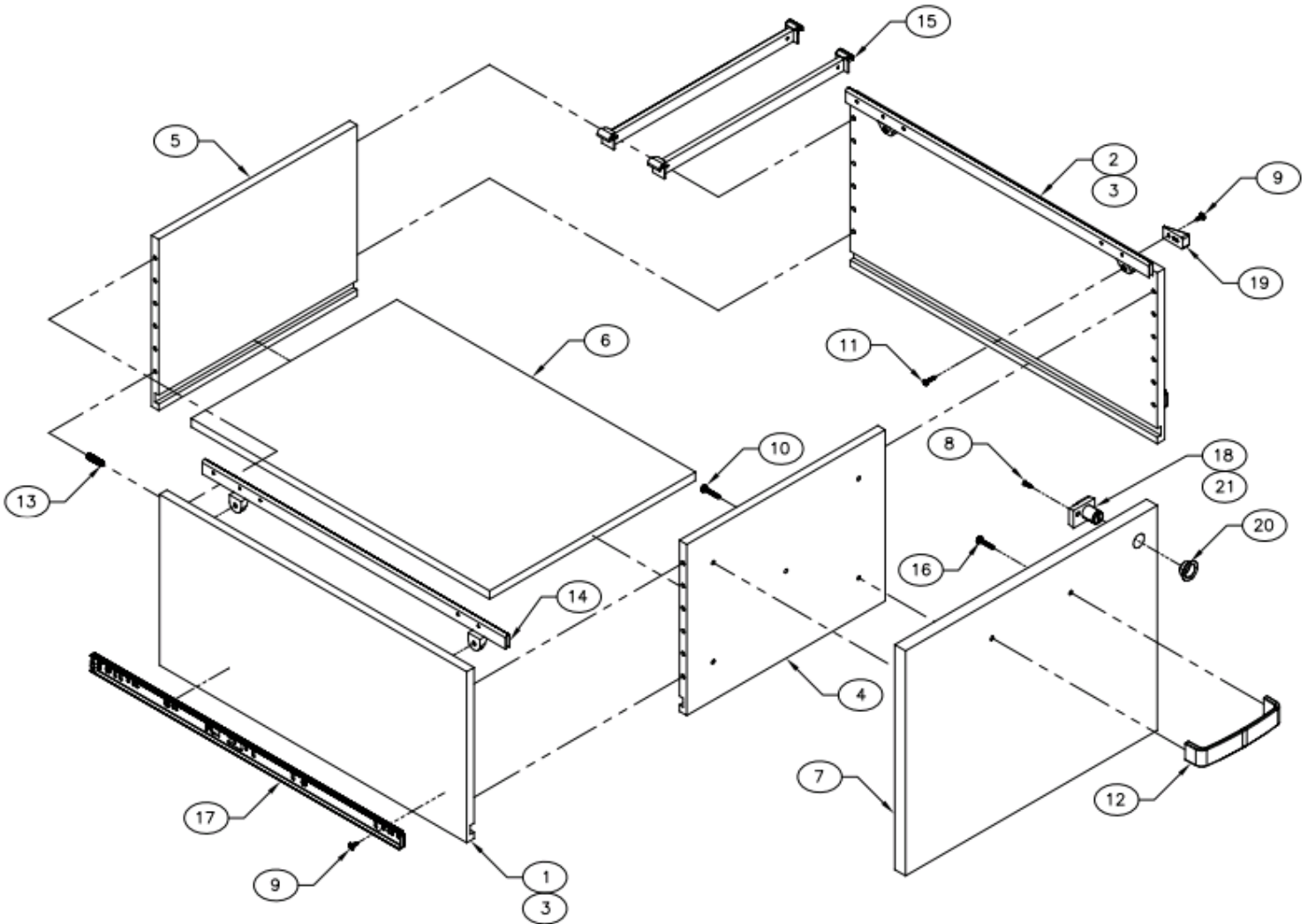

ISA130019: File Drawer Assembly with Lock

Item #	Part #	Description	Quantity
1	ISA130059	Hardware Location Left	1
2	ISA130061	Hardware Location Right	1
3	ISA130081	File Drawer Side	2
4	ISA130091	File Drawer Front	1
5	ISA1300101	File Drawer Back	1
6	ISA1300105	File Drawer Bottom	1
7	ISA1300117	File Drawer Face w/lock*	1

** The File Drawer Assembly without lock (ISA130015) drawing excludes lock parts in Items 8,18,20 & 21 and replaces Drawer Face with ISA1300115.*

Integrate Assembly Instructions
Pedestal (File/File)
(Part No. I24PD)

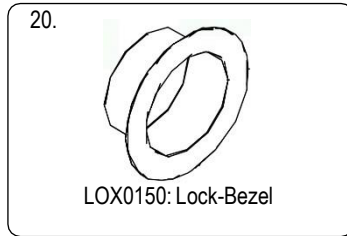
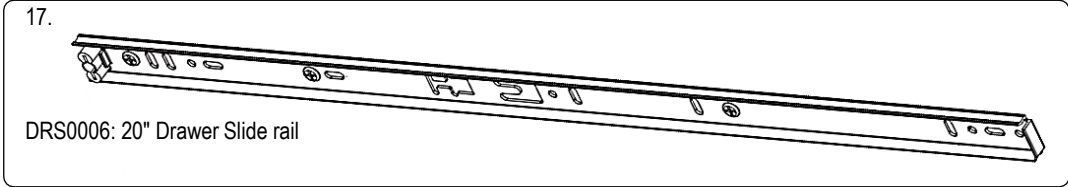
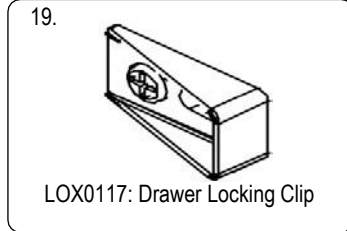
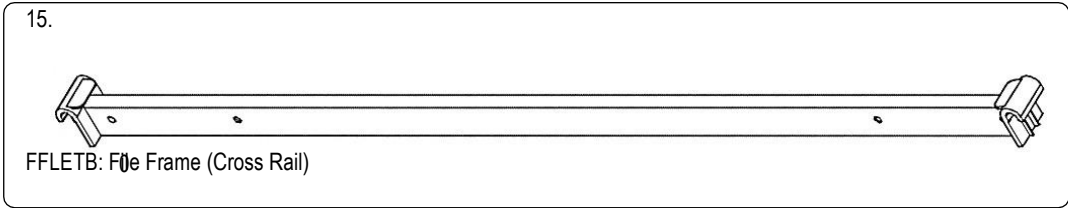
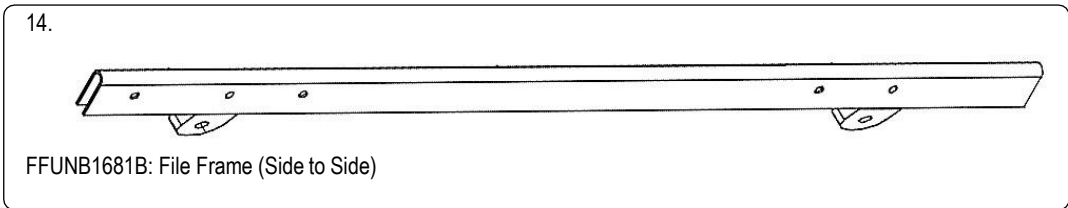
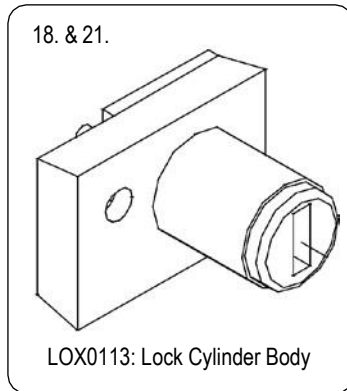
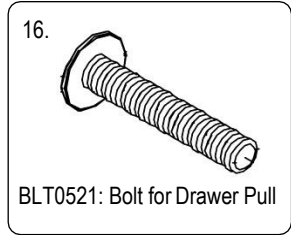
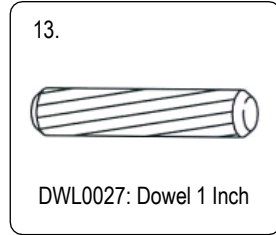
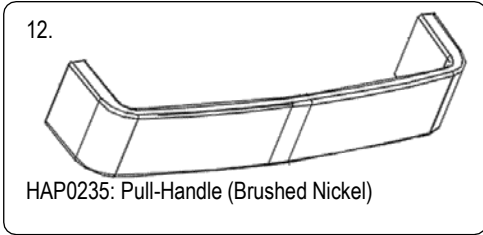
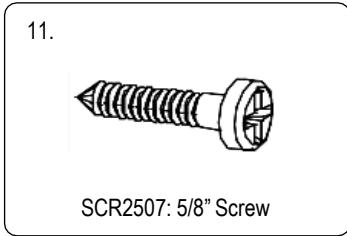
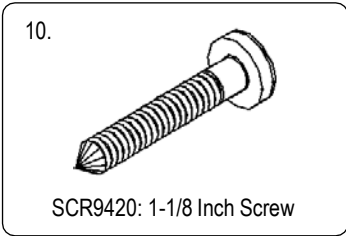
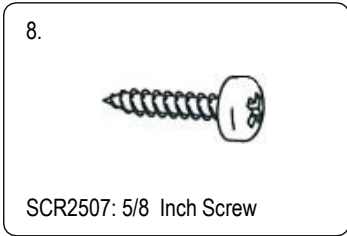

Your Final Assembled Product should look like below

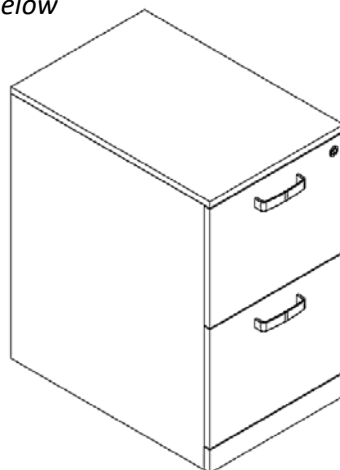



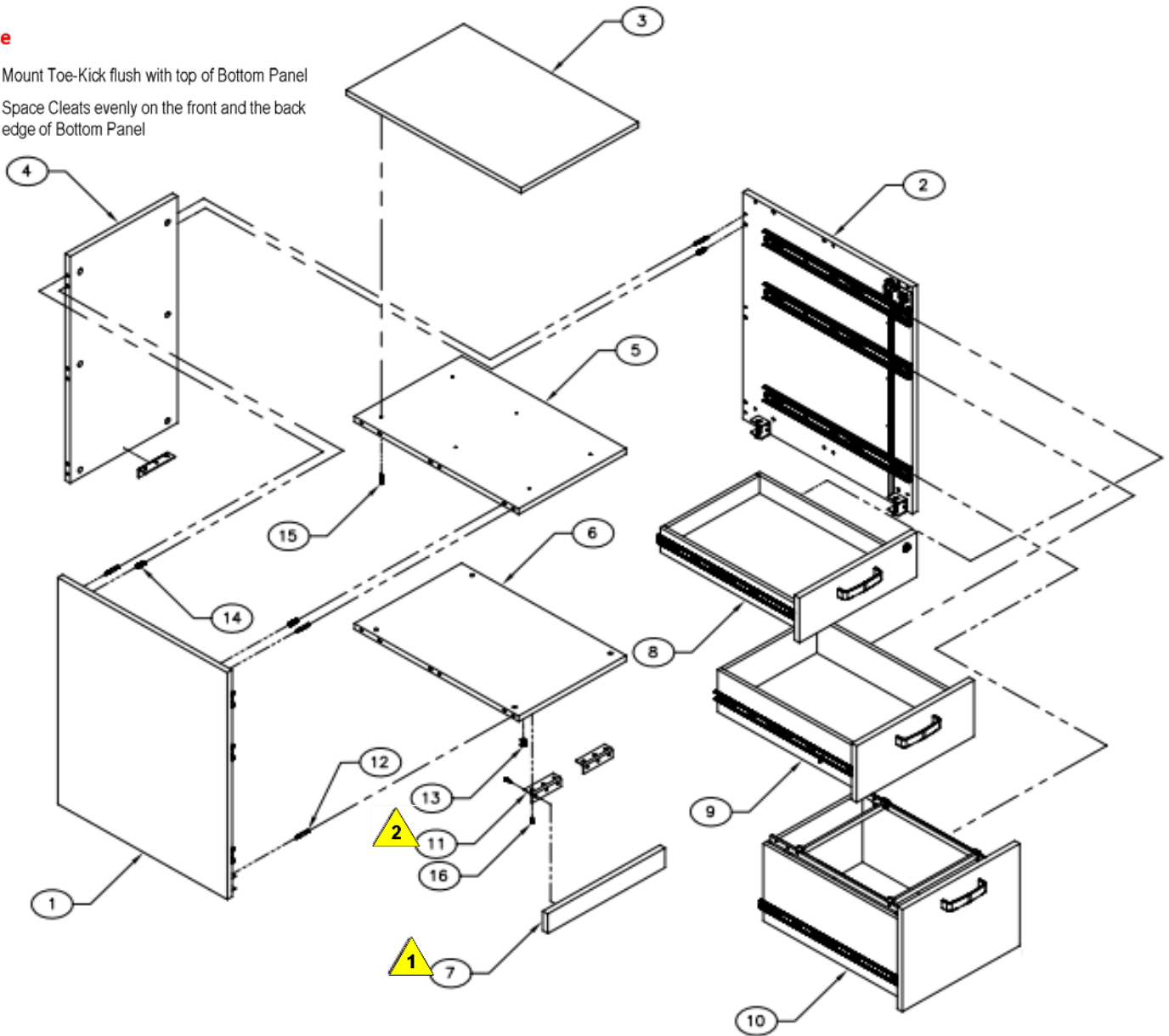

Integrate Assembly Instructions
Pedestal (Pencil/Drawer/File)
(Part No. I24PD)

- Note**
- 1** Mount Toe-Kick flush with top of Bottom Panel
 - 2** Space Cleats evenly on the front and the back edge of Bottom Panel

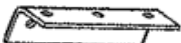

Item #	Part #	Description	Quantity
1	ISA50025	Subassembly End Panel Left	1
2	ISA50029	Subassembly End Panel Right	1
3	ISA50073	Top Panel	1
4	ISA50075	Back Panel	1
5	ISA50077	Top Interior Panel	1
6	ISA50081	Bottom Panel	1
7	ISA50085	Toe Kick Panel	1
8	ISA130001	Pencil Drawer Assembly	1
9	ISA130005	Box Drawer Assembly	1
10	ISA130015	File Drawer Assembly	1

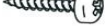
Item #	Part #	Description	Quantity
11	BRB0441	Steel Cleats 	3
12	CTR21504	Bolts 	18
13	CTR21541	Cam Locks 	18
14	DWL0027	Dowel 1 Inch 	18
15	SCR0677	Screw 1-1/4 Inch 	6
16	SCR2507	Screw 5/8 Inch 	18

Integrate Assembly Instructions
Pedestal (Pencil/Drawer/File)

(Part No. I24PD)

ISA50029 Subassembly End Panel Right

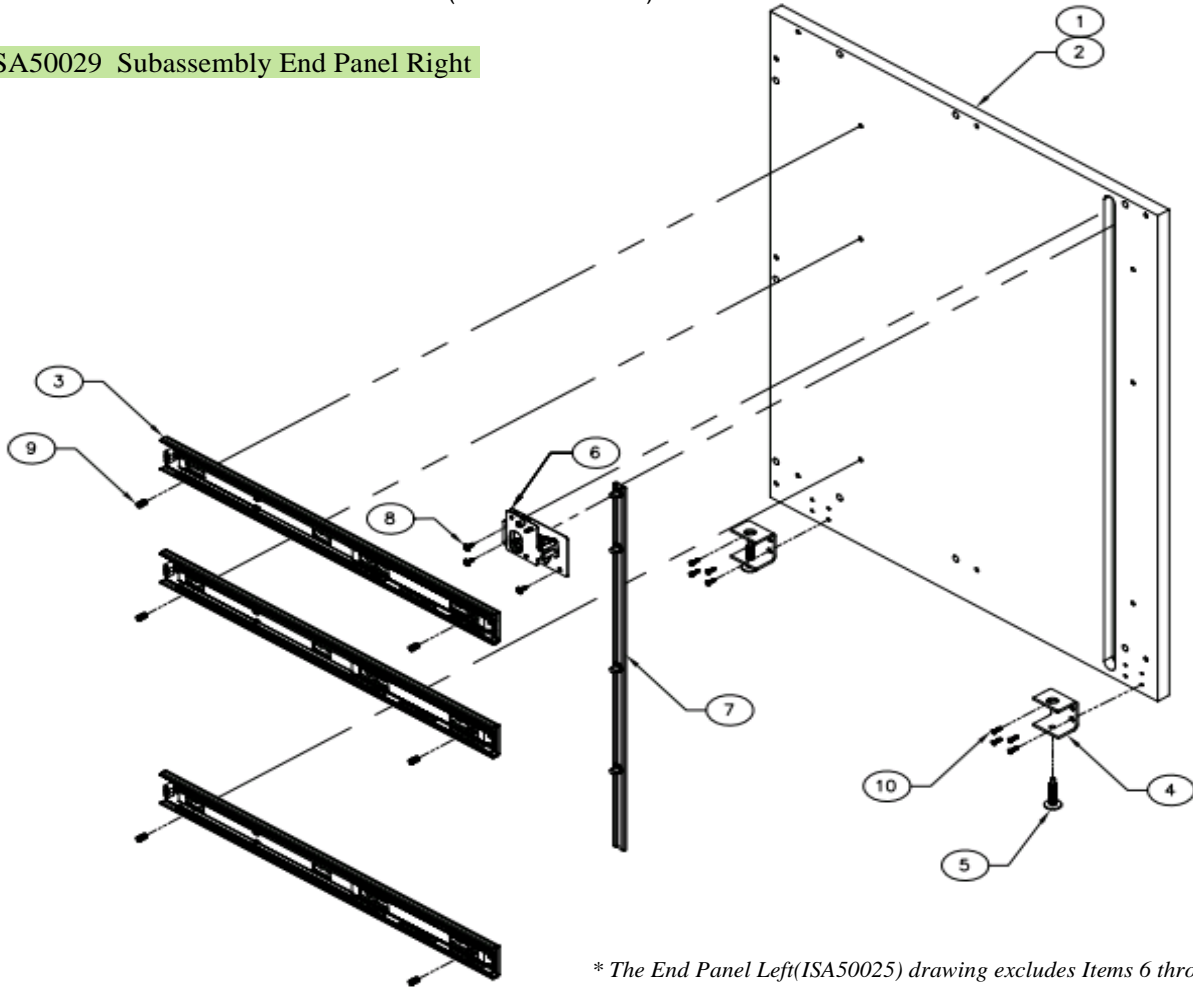

* The End Panel Left(ISA50025) drawing excludes Items 6 through 8.

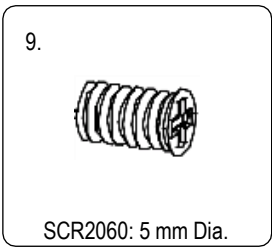
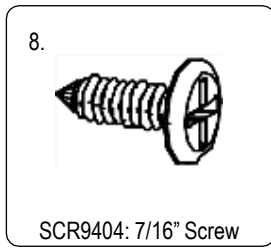
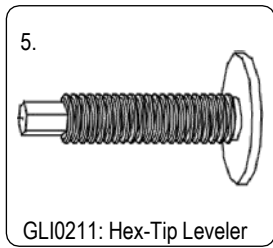
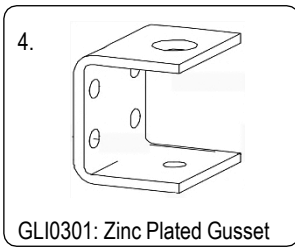
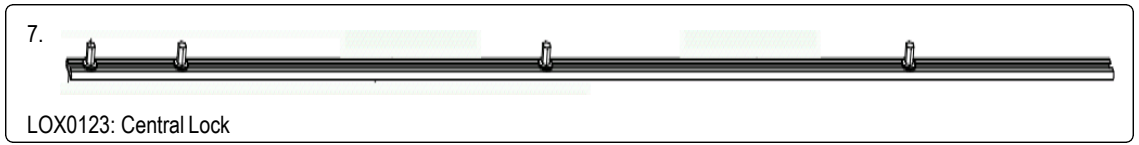
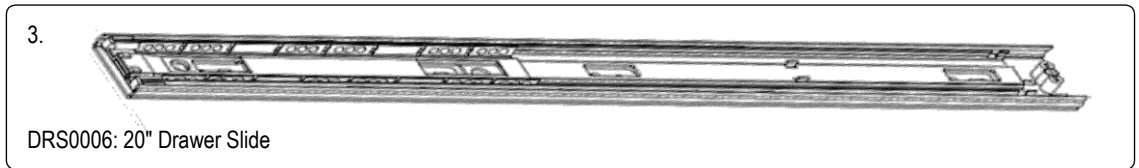
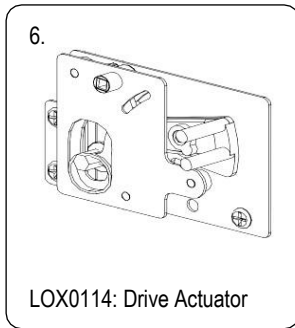

Integrate Assembly Instructions
Pedestal (Pencil/Drawer/File)
(Part No. I24PD)

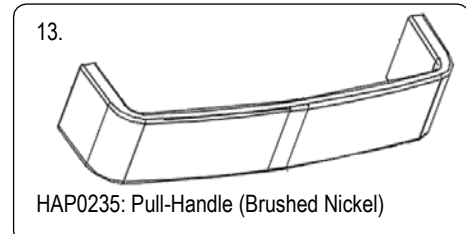
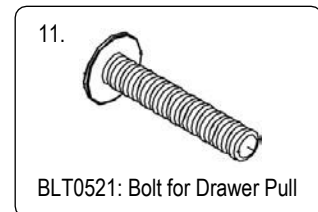
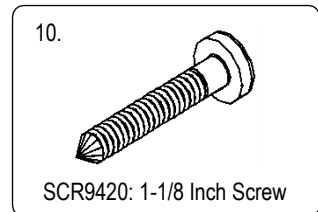
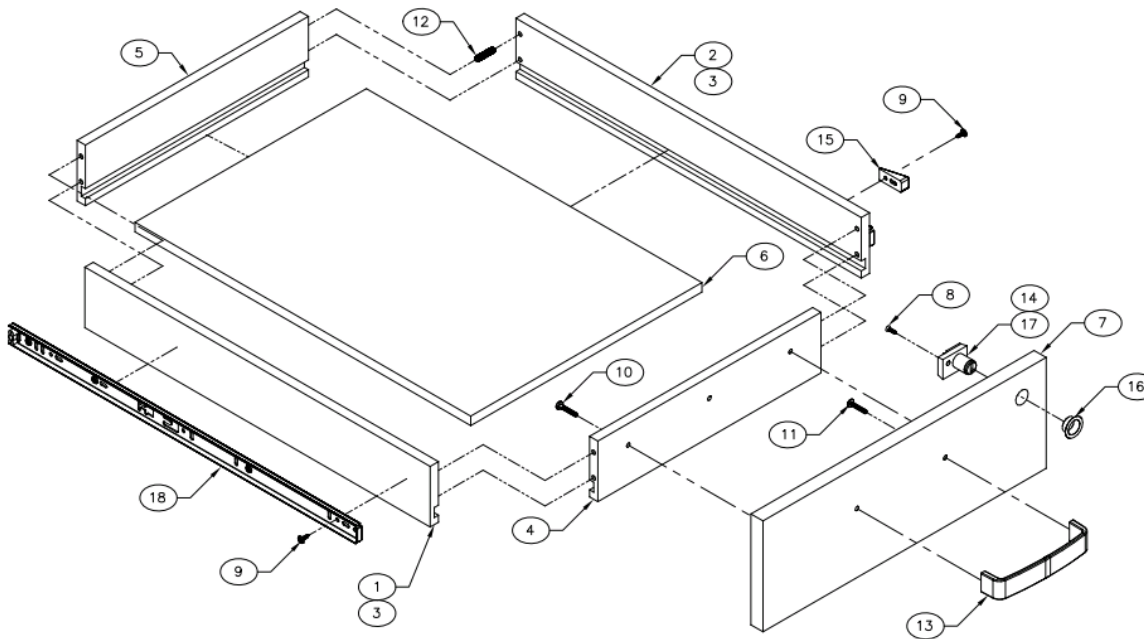

ISA130001: Pencil Drawer with Lock

Item #	Part #	Description	Quantity
1	ISA130043	Hardware Location Left	1
2	ISA130045	Hardware Location Right	1
3	ISA130075	Pencil Drawer Side	2
4	ISA130085	Pencil Drawer Front	1
5	ISA130095	Pencil Drawer Back	1
6	ISA1300105	Pencil Drawer Bottom	1
7	ISA1300109	Pencil Drawer Face	1

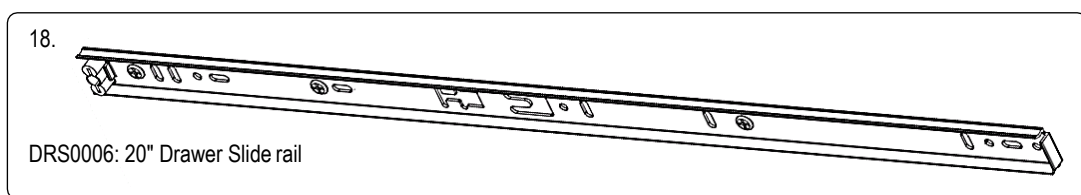
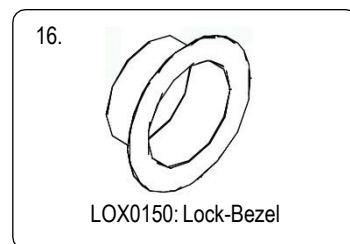
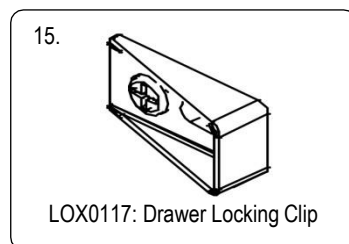
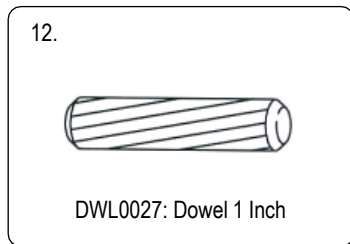
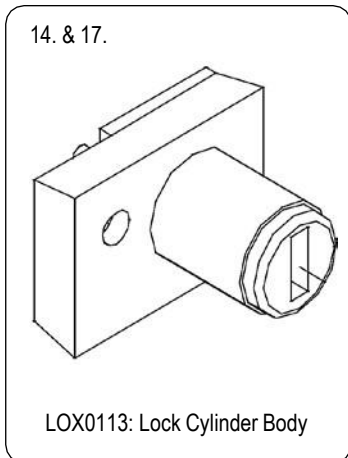

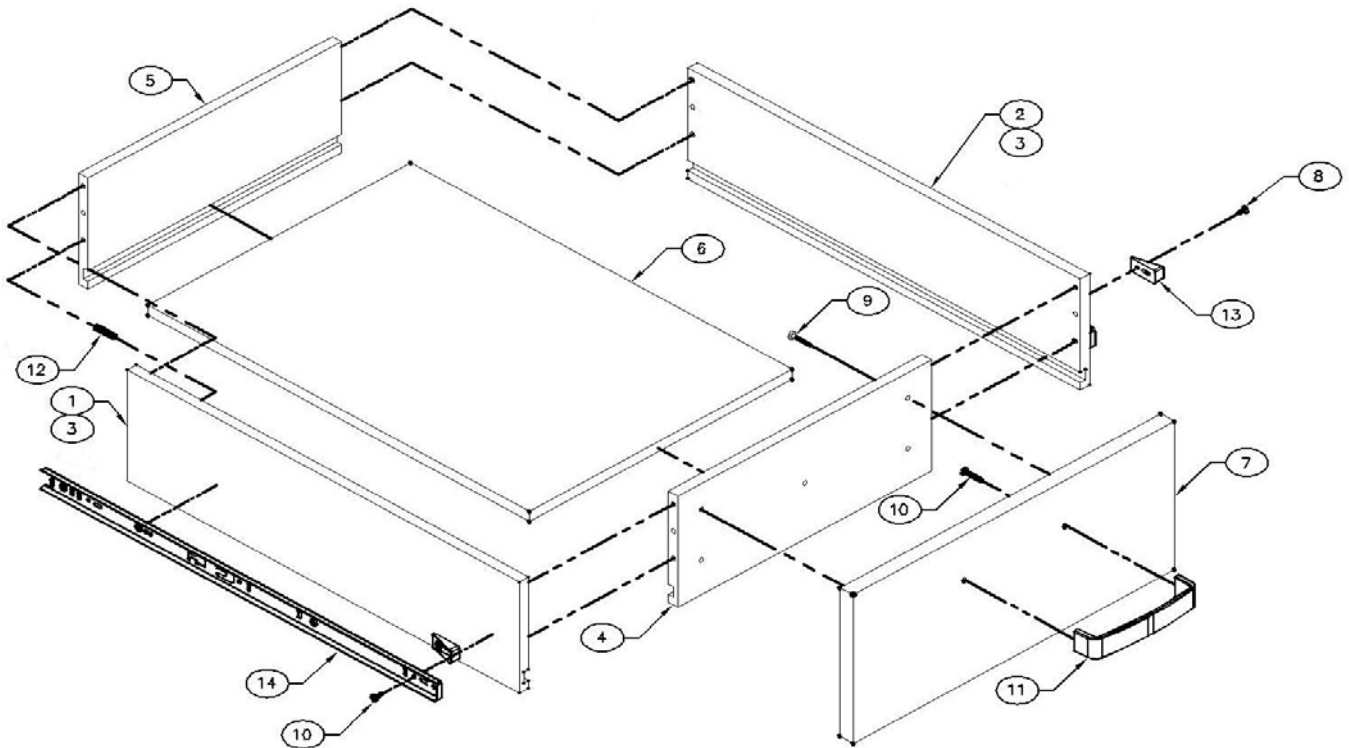

ISA130005: Box Drawer with Lock

Item #	Part #	Description	Quantity
1	ISA130047	Hardware Location Left	1
2	ISA130053	Hardware Location Right	1
3	ISA130077	Box Drawer Side	2
4	ISA130087	Box Drawer Front	1
5	ISA130097	Box Drawer Back	1
6	ISA1300105	Box Drawer Bottom	1
7	ISA1300111	Box Drawer Face	1

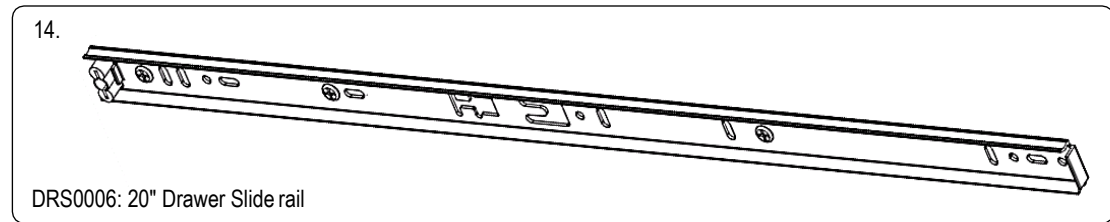
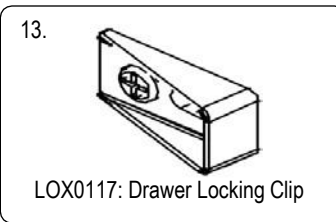
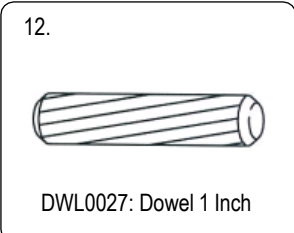
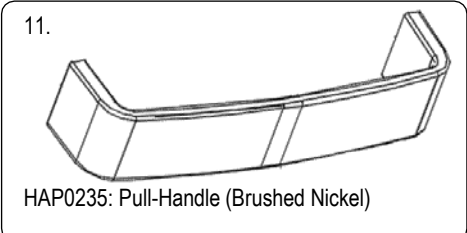
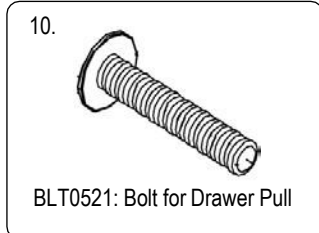
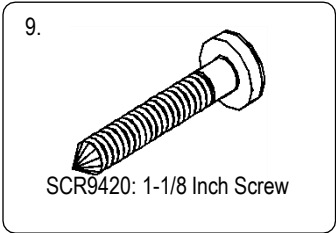

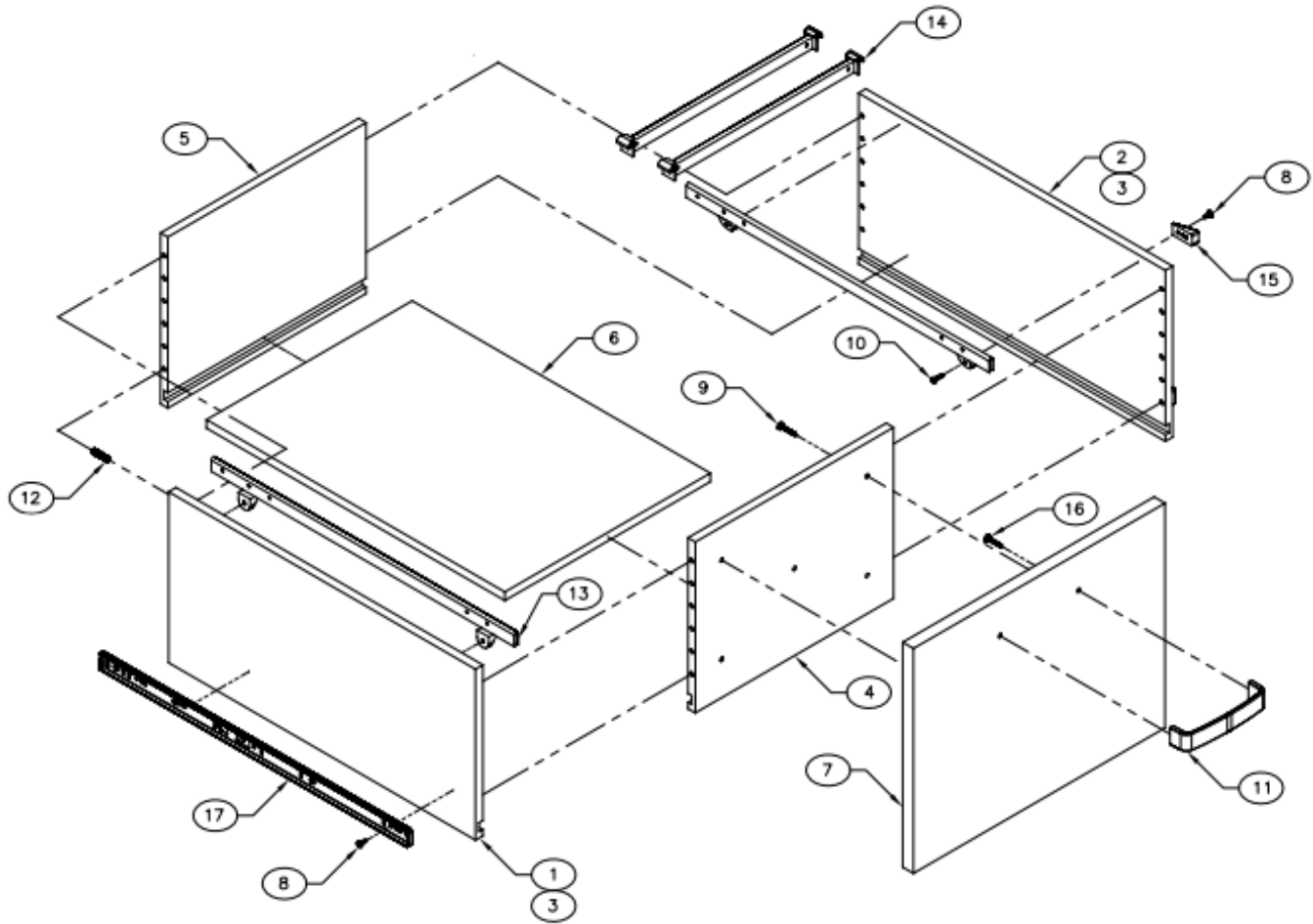

ISA130015: File Drawer Assembly

Item #	Part #	Description	Quantity
1	ISA130059	Hardware Location Left	1
2	ISA130061	Hardware Location Right	1
3	ISA130081	File Drawer Side	2
4	ISA130091	File Drawer Front	1
5	ISA1300101	File Drawer Back	1
6	ISA1300105	File Drawer Bottom	1
7	ISA1300115	File Drawer Face	1

**Integrate Assembly Instructions
Pedestal (Pencil/Drawer/File)**

(Part No. I24PD)

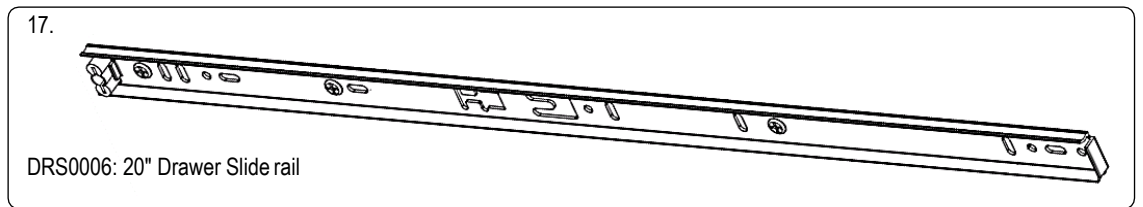
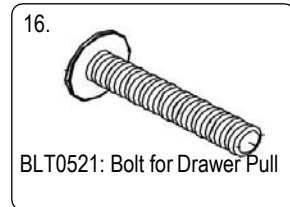
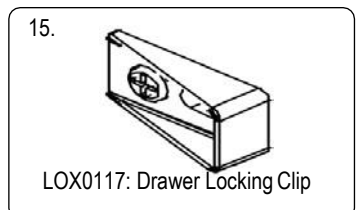
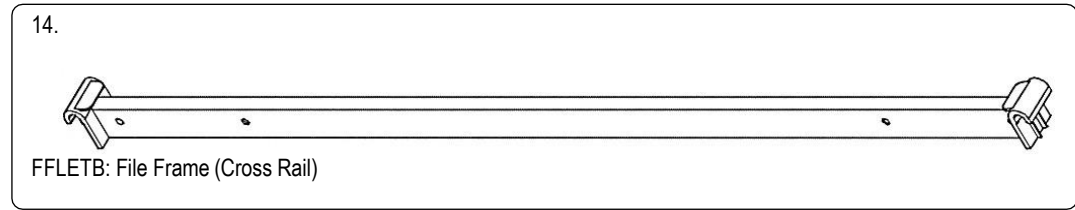
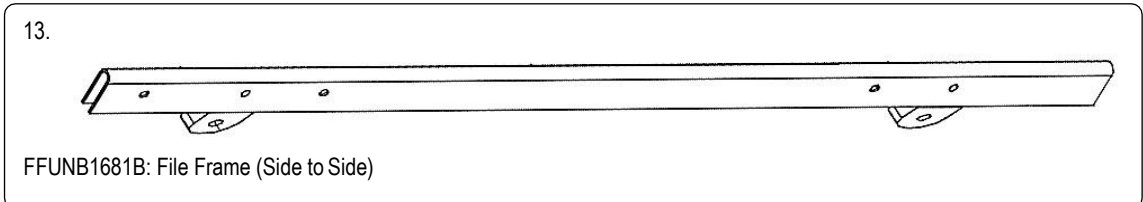
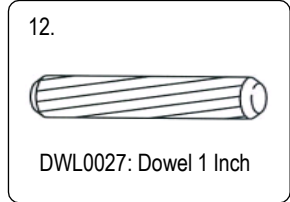
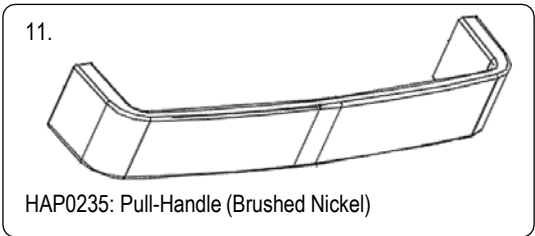
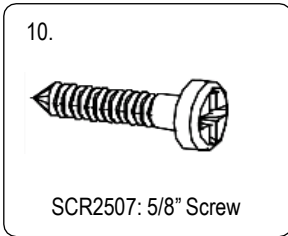
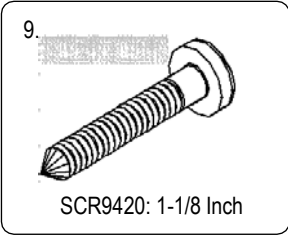



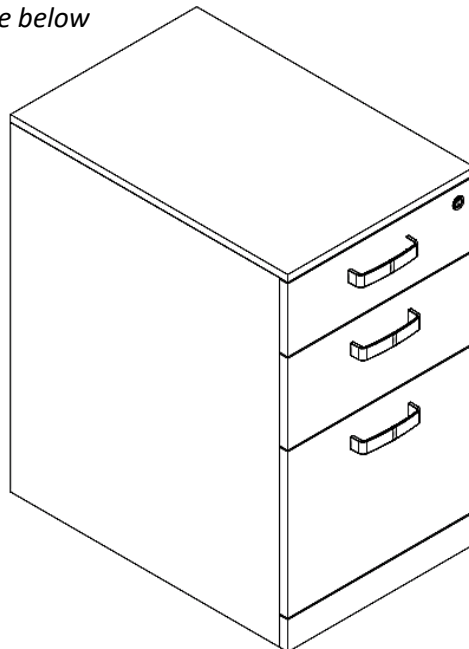

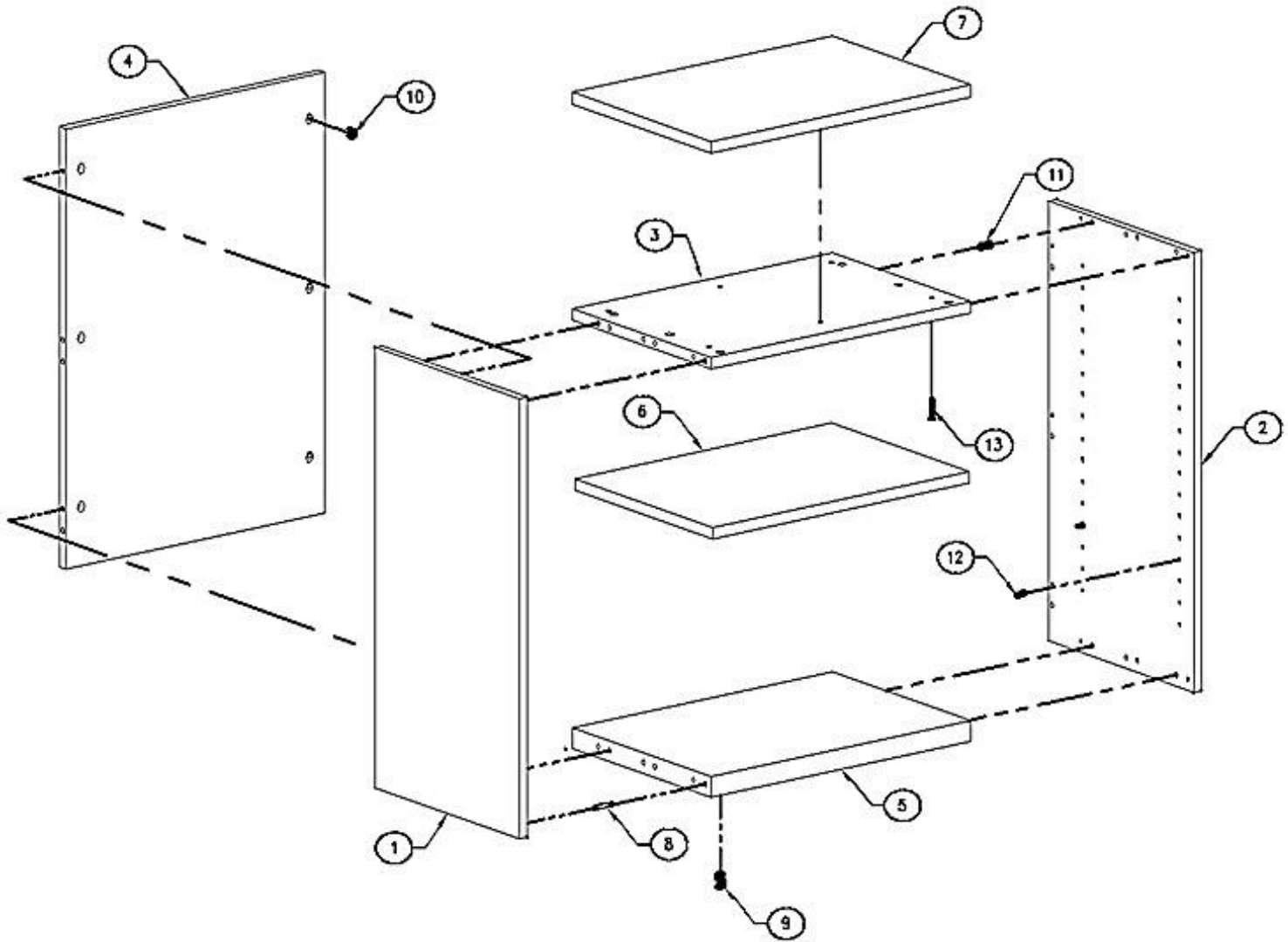

Your Final Assembled Product should look like below



Integrate Assembly Instructions
Upper Side Shelving Storage Unit 24"
(Part No. I24SS)



Item #	Part #	Description	Quantity	Item #	Part #	Description	Quantity
1	ISA100005	Left End Panel	1	8	CTR21504	Bolts 	18
2	ISA100007	Right End Panel	1	9	CTR21516	Cam Locks 19 MM Black 	6
3	ISA100009	Top Interior Panel	1	10	CTR21541	Cam Locks 	12
4	ISA100011	Back Panel	1	11	DWL0027	Dowel 1 Inch 	18
5	ISA100013	Bottom Panel	1	12	PIN4000	Shelf Supporting Pins 	4
6	ISA100015	Shelf Panel	1	13	SCR0677	Screw 1-1/4 Inch 	12
7	ISA100017	Top Panel	1				

Integrate Assembly Instructions
Upper Side Shelving Storage Unit 24"

(Part No. I24SS)

STEP 1: INSERT BOLTS AND DOWELS TO SIDE PANELS

Place the End Panel Left (Item 1) and End Panel Right (Item 2) on a flat surface. Insert 9 wood dowels (Item 11) and screw 9 Connecting Bolts (Item 8) each in the holes provided on both the panels.

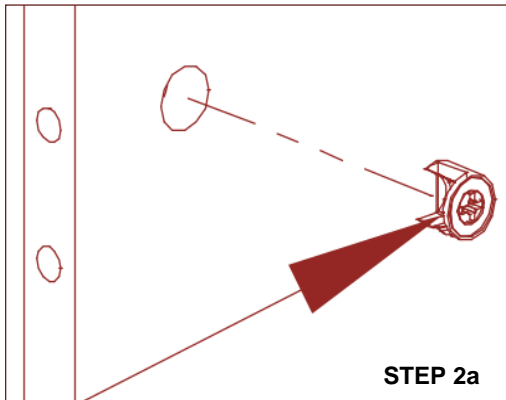
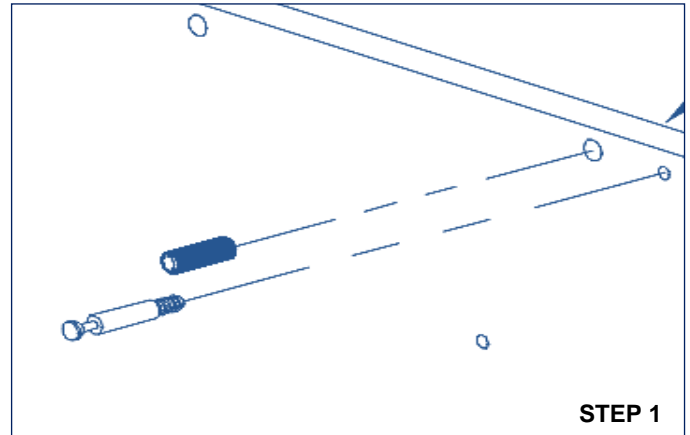

STEP 2: INSERT CAM-LOCKS TO TOP, BOTTOM AND BACK PANEL

- (a) Insert 6 cams (Item 10) each in the holes provided on the Back Panel (item 4) and on top Interior Panel (Item 3).
- (b) Insert 6 cams (Item 9) in the holes provided on the Bottom Panel (item 5).
- (c) Place the Back panel at right angles on the Left (or Right) End panel (Items 1 OR 2) and place the Top & Bottom panel on the side Panel so that the Dowels and Bolts are inserted into the pre-drilled holes on the edge of the panels.

Twist-lock all the cams with a Philips screw-driver to the Connecting bolts on the end panels. Now take the opposite End-Panel (left or right), place it on the assembly so that the Dowels and Bolts are inserted into the pre-drilled holes on the edge of the panels and twist-lock the cams into the Connecting Bolts on the End Panel.

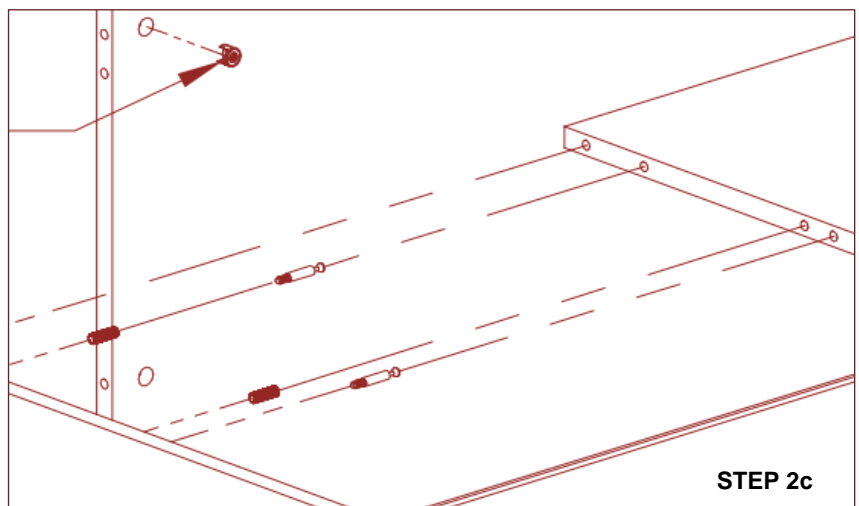
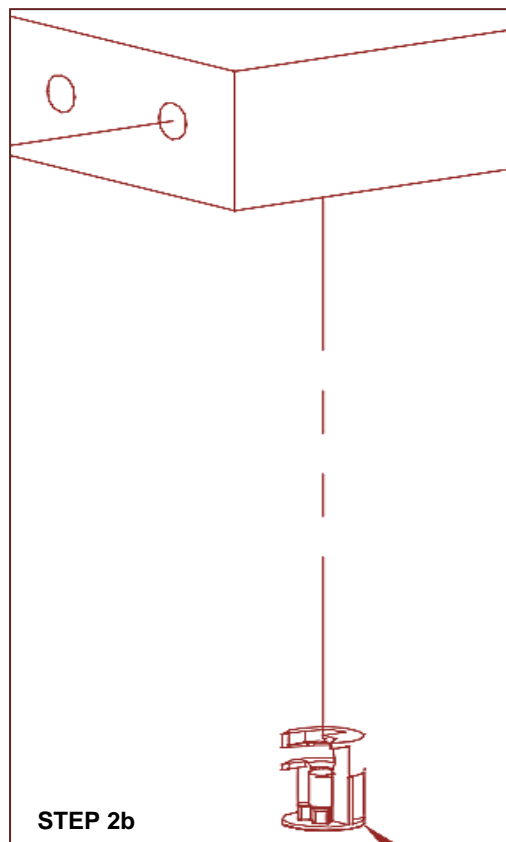

STEP 3: INSERT SHELF-PINS AND SHELVES IN THE ASSEMBLED PRODUCT

Insert the shelf supporting pins (Item 12) at the desired height of the shelf and place the Shelf Panel (6) on the pins.

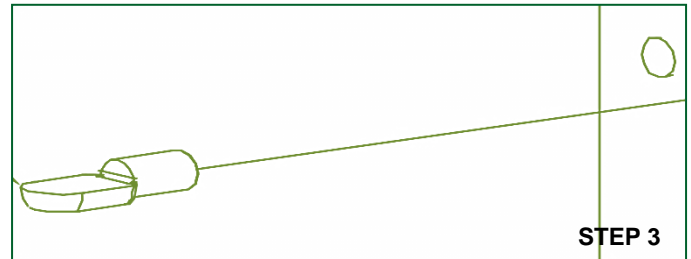

STEP 4: ATTACH THE TOP PANEL AND THE SIDE SHELVING ASSEMBLY TO PEDESTAL

- (a) Place the Top Panel (Item 7) on the assembled product and attach it to the Interior Top panel with the 6 screws (Item 13) through the holes provided in the interior top panels.
- (b) Place the Complete assembly of the Side-Shelving unit on the Integrate Worksurface supporting base units (I24PDW or I16CBCW) and attach the Side-Shelving Unit to the base with 6 screws (item 13) from the interior top panel of the base.

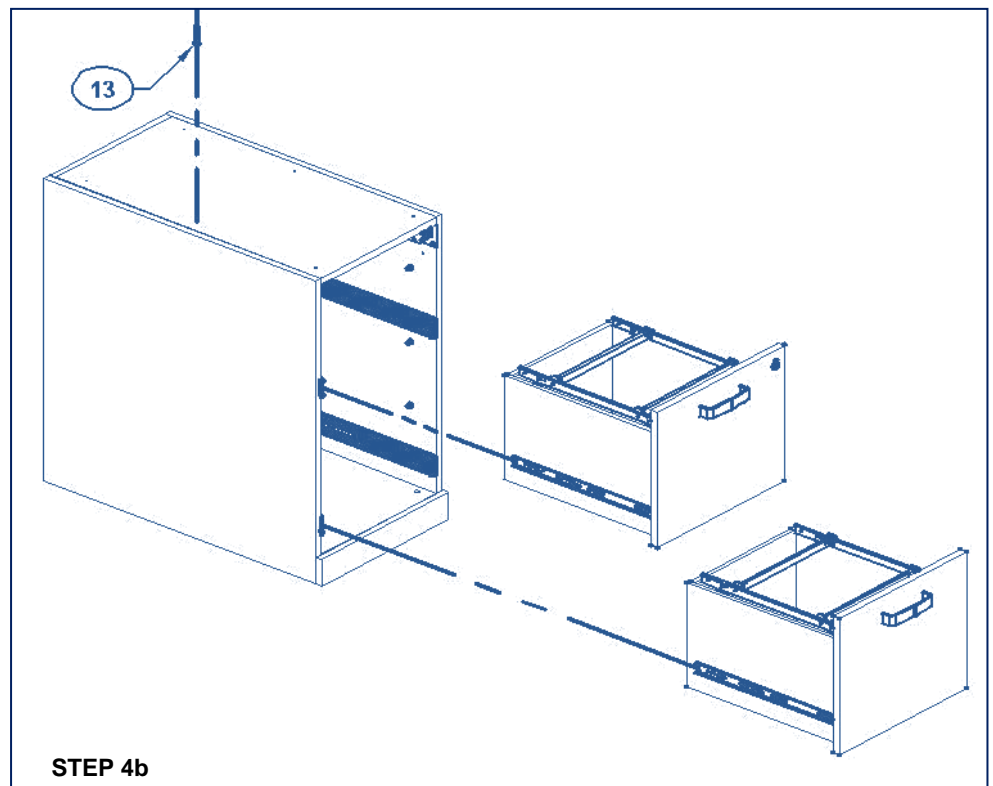
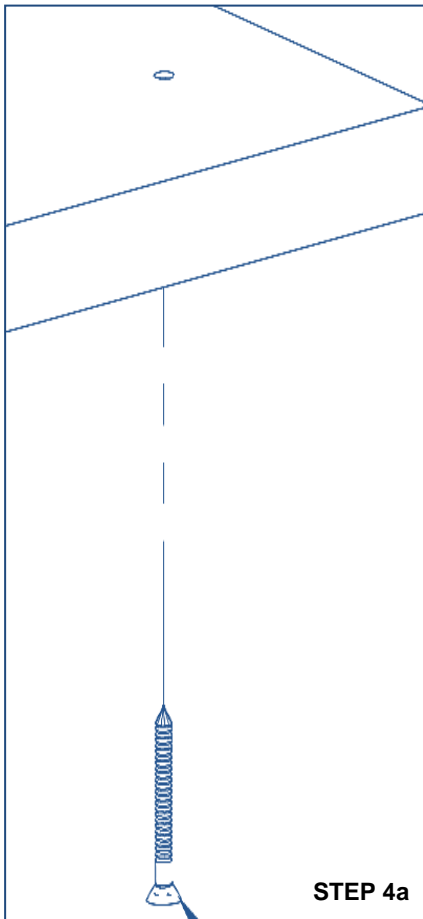

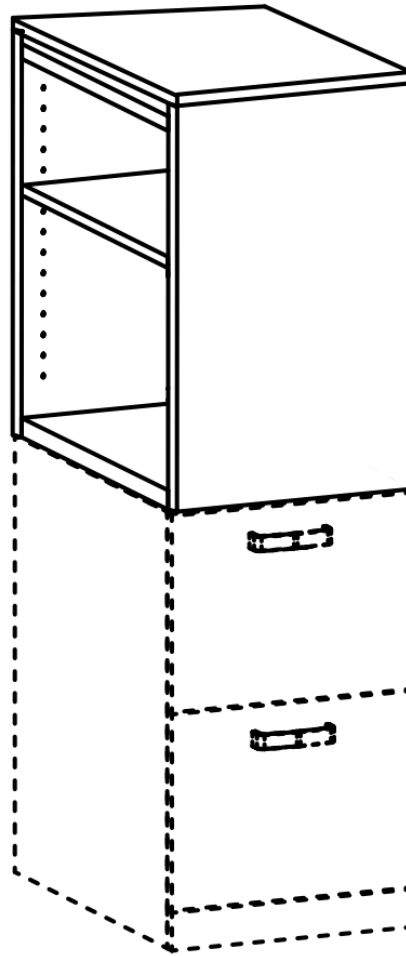

Integrate Assembly Instructions
Upper Side Shelving Storage Unit 24"
(Part No. I24SS)

Your Final Assembled Product should look like below: (Image shown with I24PDW-FF base)



Integrate Assembly Instructions
Upper Side Shelving Storage Unit 24"
(Part No. I24SS)

Note

-  Mount Toe-Kick flush with top of Bottom Panel
-  Space Cleats evenly on the front and the back edge of Bottom Panel

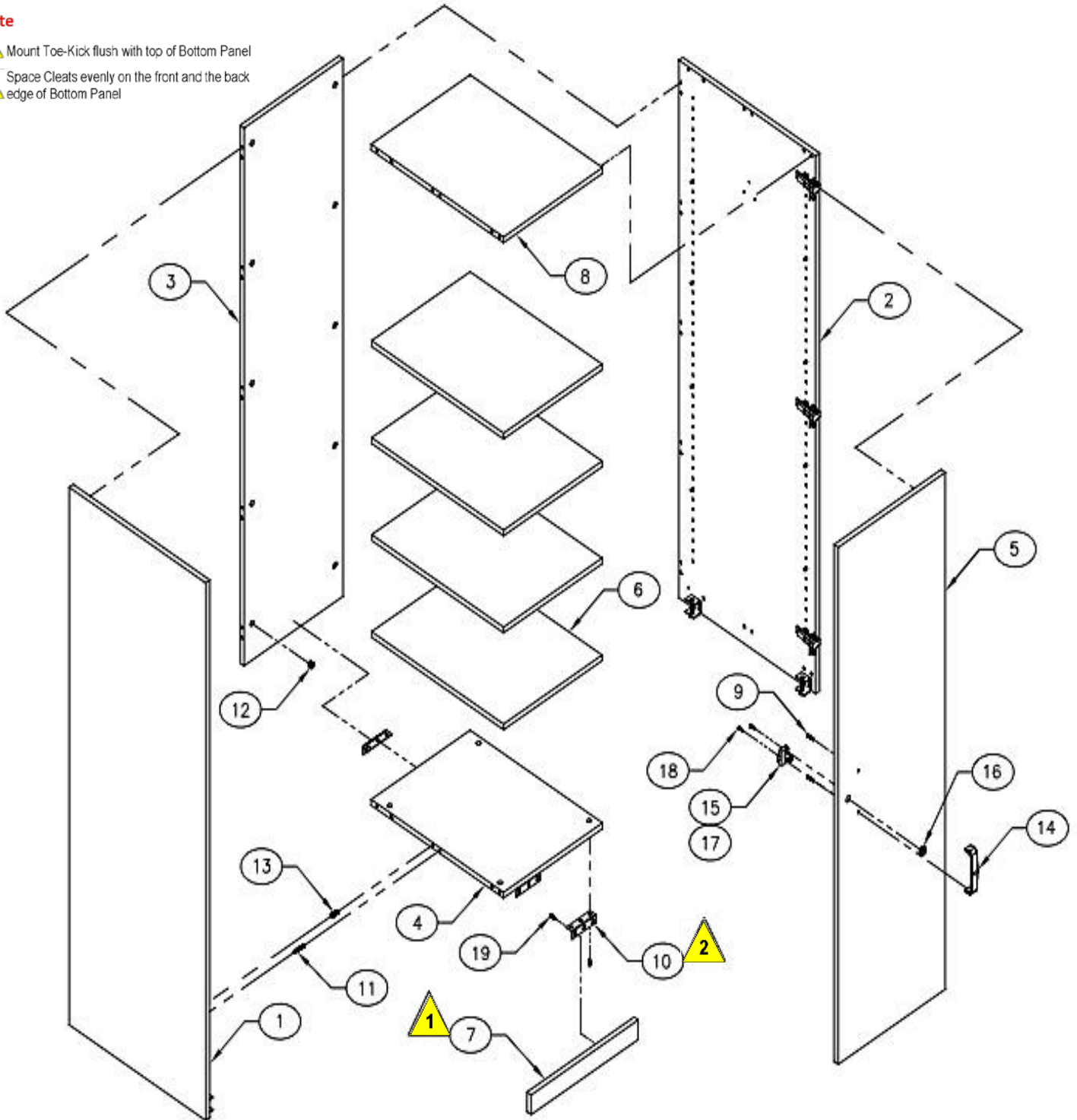

Item #	Part #	Description	Quantity
1	ISA110017	Left End Panel Subassembly	1
2	ISA110021	Right End Panel Subassembly	1
3	ISA110031	Back Panel	1
4	ISA110033	Bottom Panel	1
5	ISA110035	Door Panel	1
6	ISA110037	Shelf Panel	4
7	ISA110039	Toe Kick Panel	1
8	ISA110041	Top Interior Panel	1

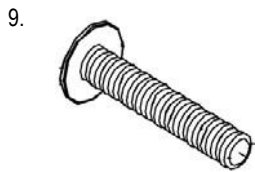

BLT0521: Bolt for Drawer Pull

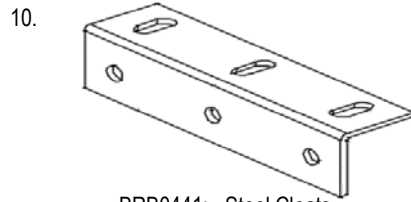

BRB0441: Steel Cleats

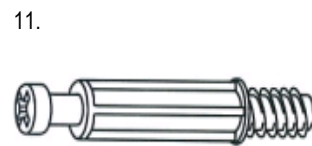

CTR21504: Bolts

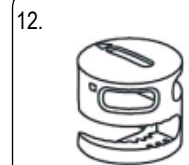

CTR21541: Cam Locks



DWL0027: Dowel 1 Inch

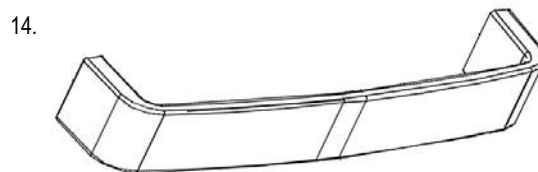

HAP0235: Pull-Handle (Brushed Nickel)

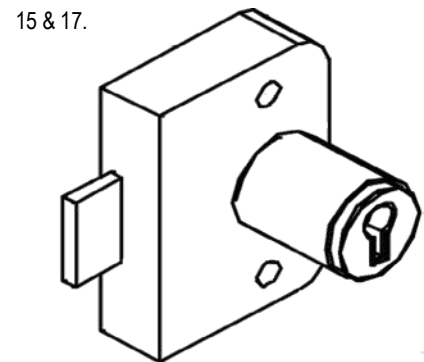

LOX0100: Lock Assembly &
LOX323: Lock Core

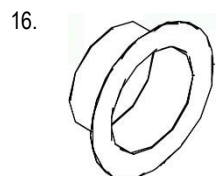

LOX0150: Lock-Bezel

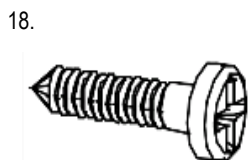

SCR2507: #6, .625 Screw



SCR2507: 5/8" Screw

Storage Cabinet Right Panel Assembly (ISA110021)

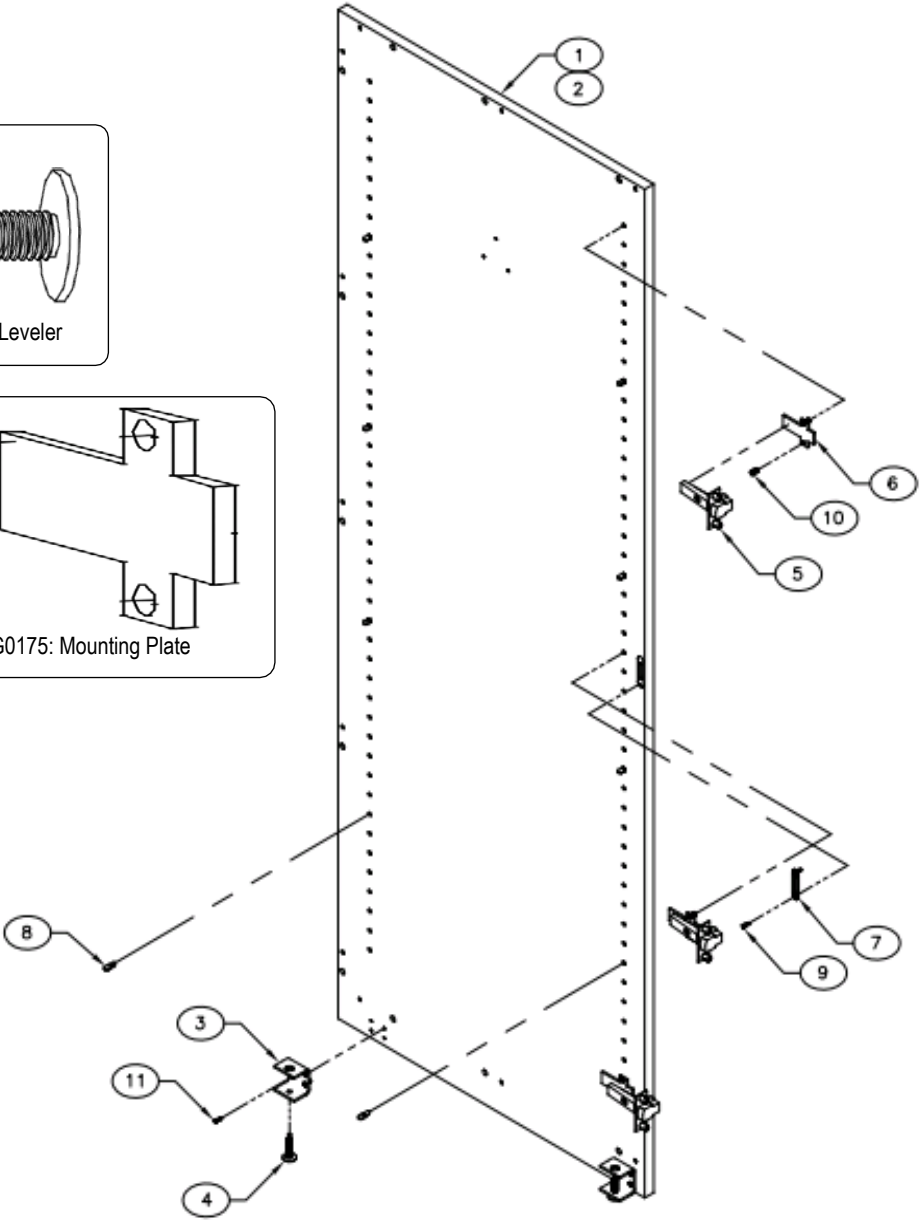
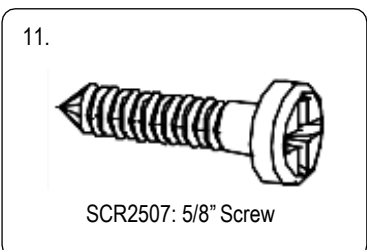
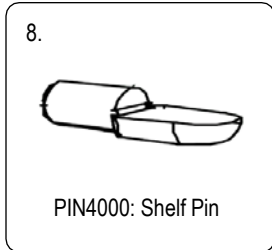
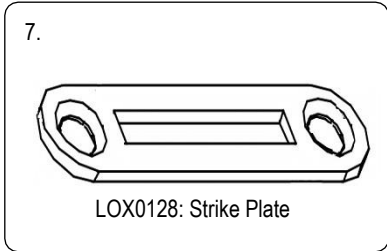
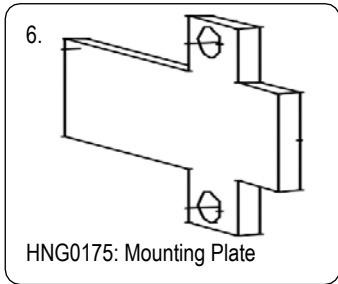
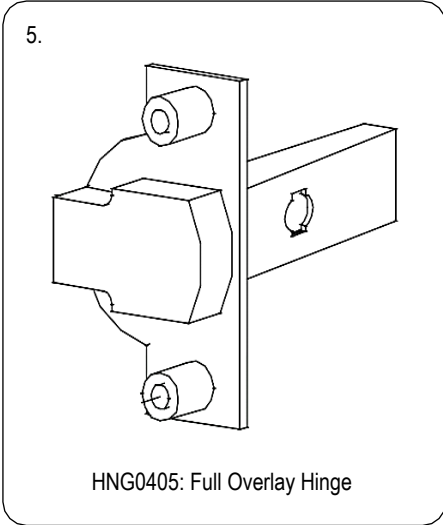
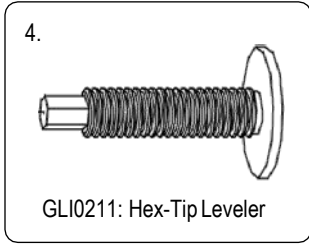
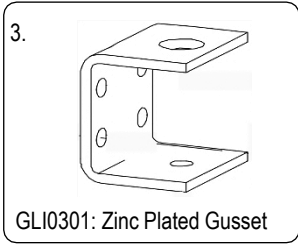

Storage Cabinet Left Panel Assembly (ISA110017)

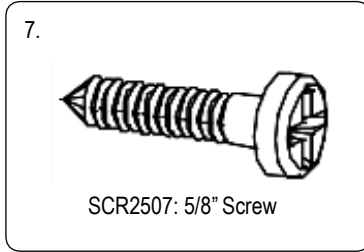
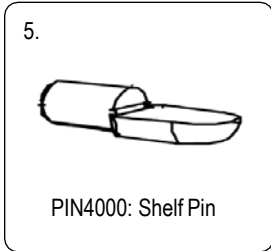
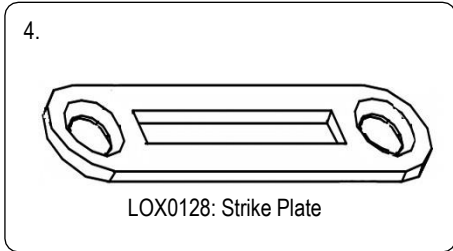
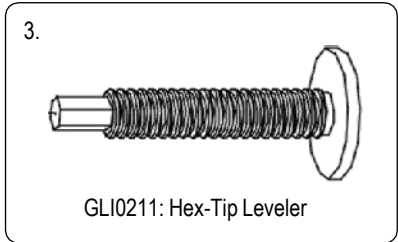
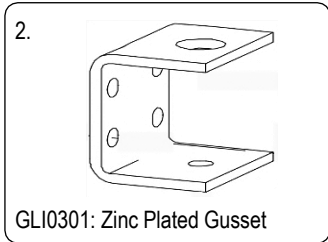
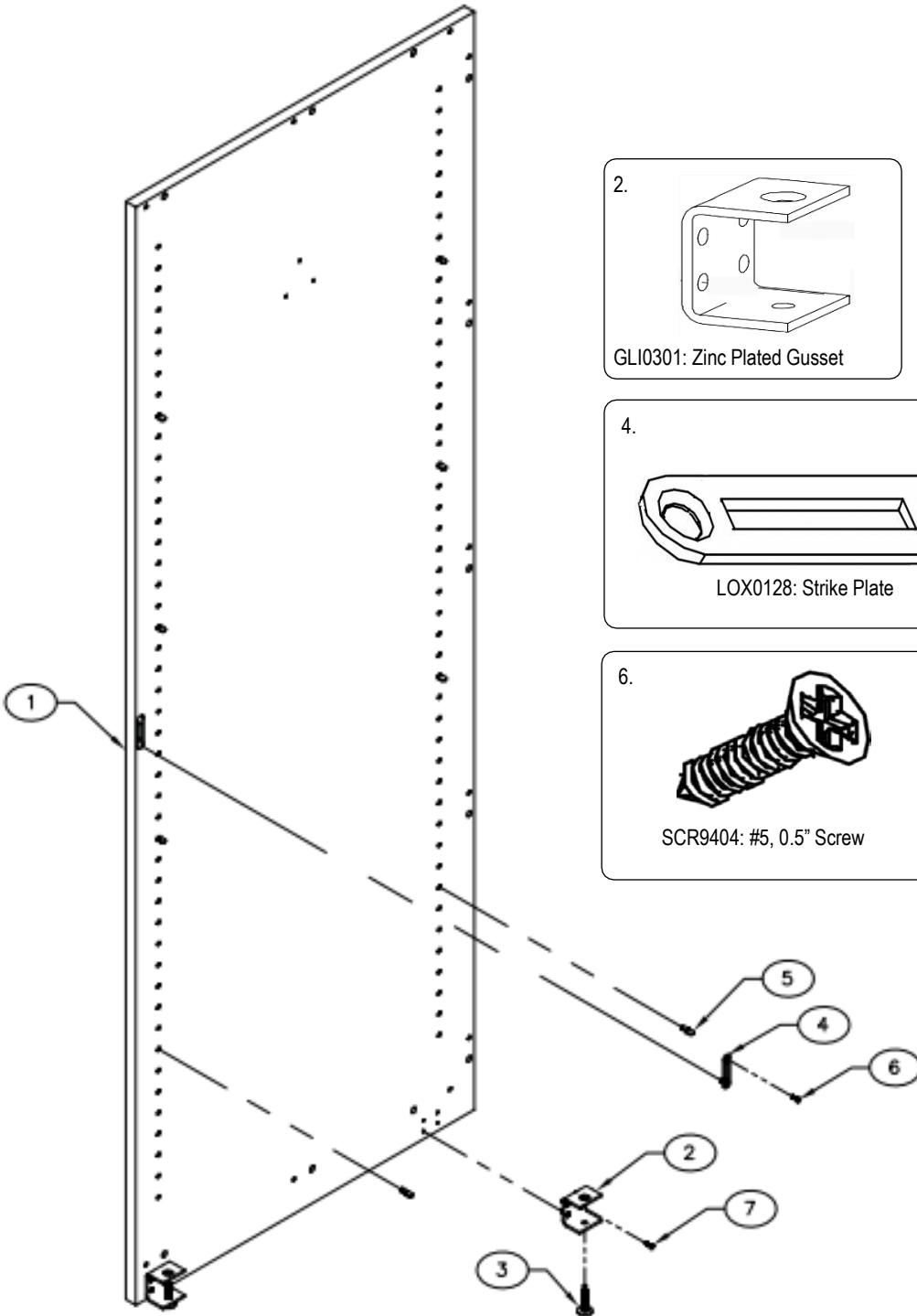

Integrate Assembly Instructions
Storage Cabinet
(Part No. I1867SCC)

Your Final Assembled Product should look like below

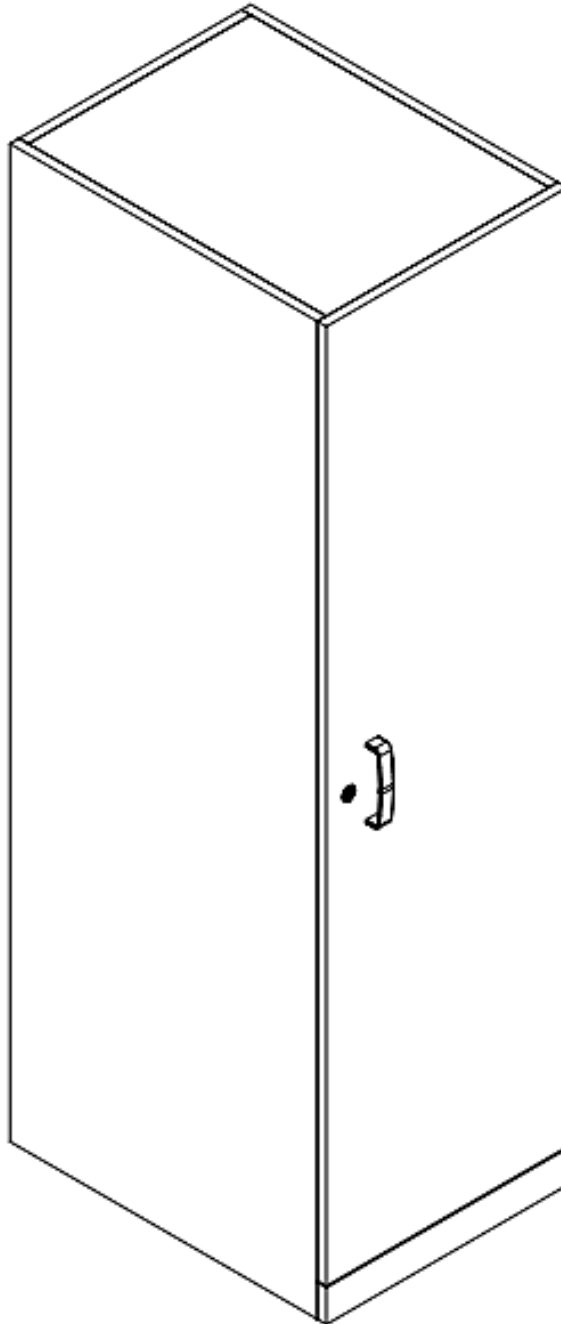

Integrate Assembly Instructions
Upper Shelving Unit 16" Closed
(Part No. I16USC)

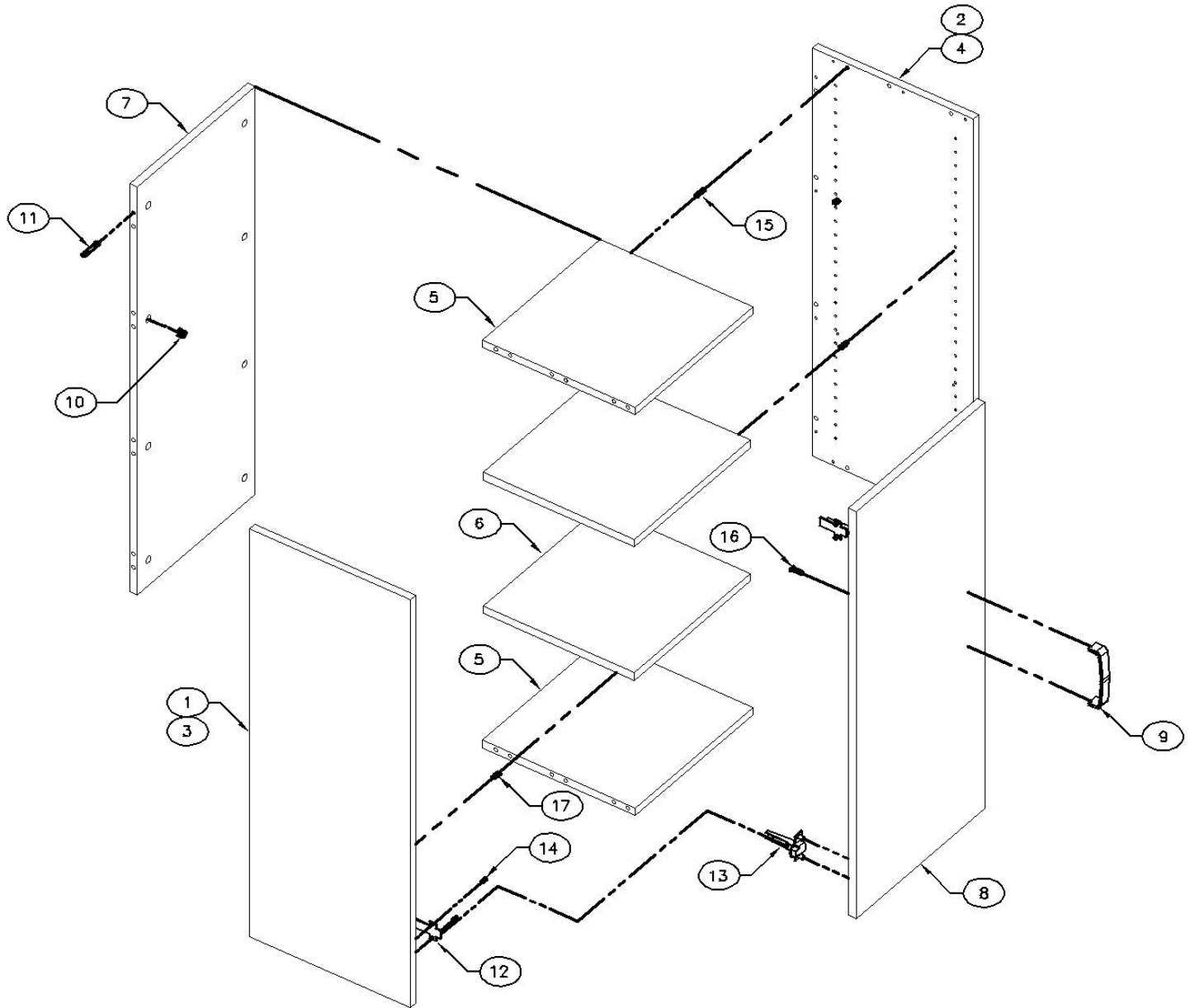

Item #	Part #	Description	Quantity
1 & 3	ISA80009	Left End Panel & Hardware	1
2 & 4	ISA80011	Right End Panel & Hardware	1
5	ISA80017	Top & Bottom Panel	2
6	ISA80021	Shelf Panel	2
7	ISA80025	Back Panel	1
8	ISA80029	Door Panel	2

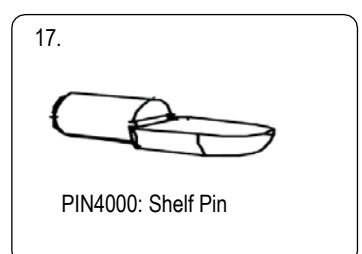
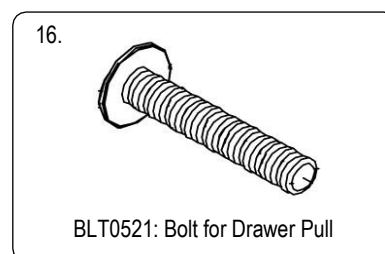
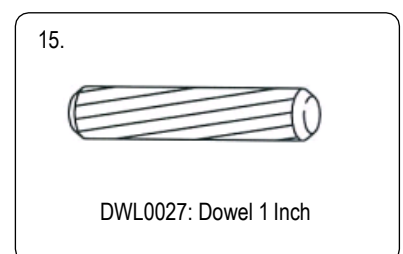
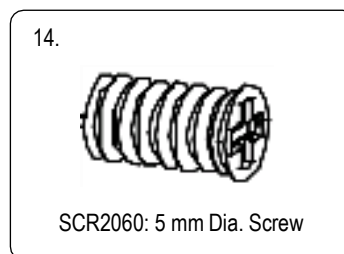
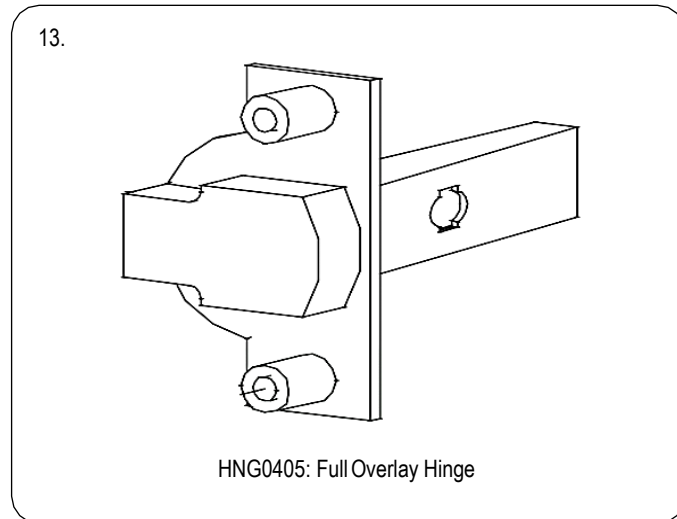
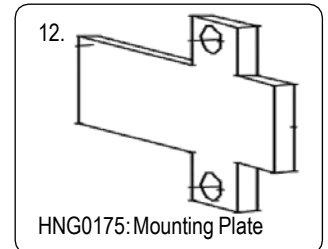
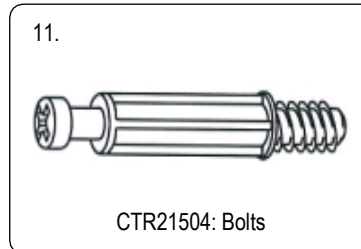
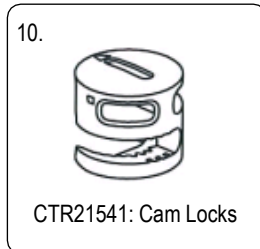
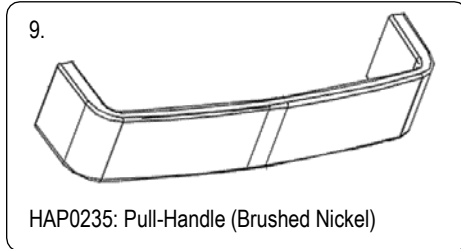

Your Final Assembled Product should look like below

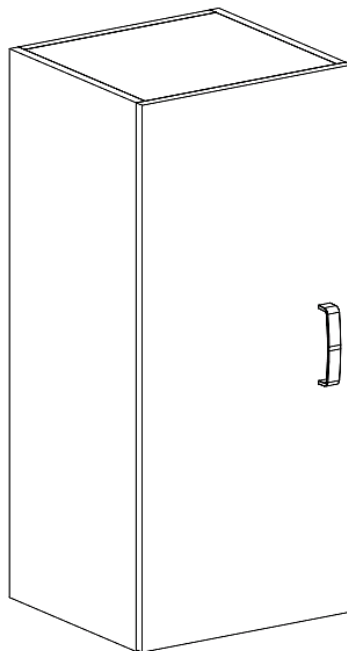

Integrate Assembly Instructions
Upper Shelving Unit 16" Open
(Part No. I16USO)

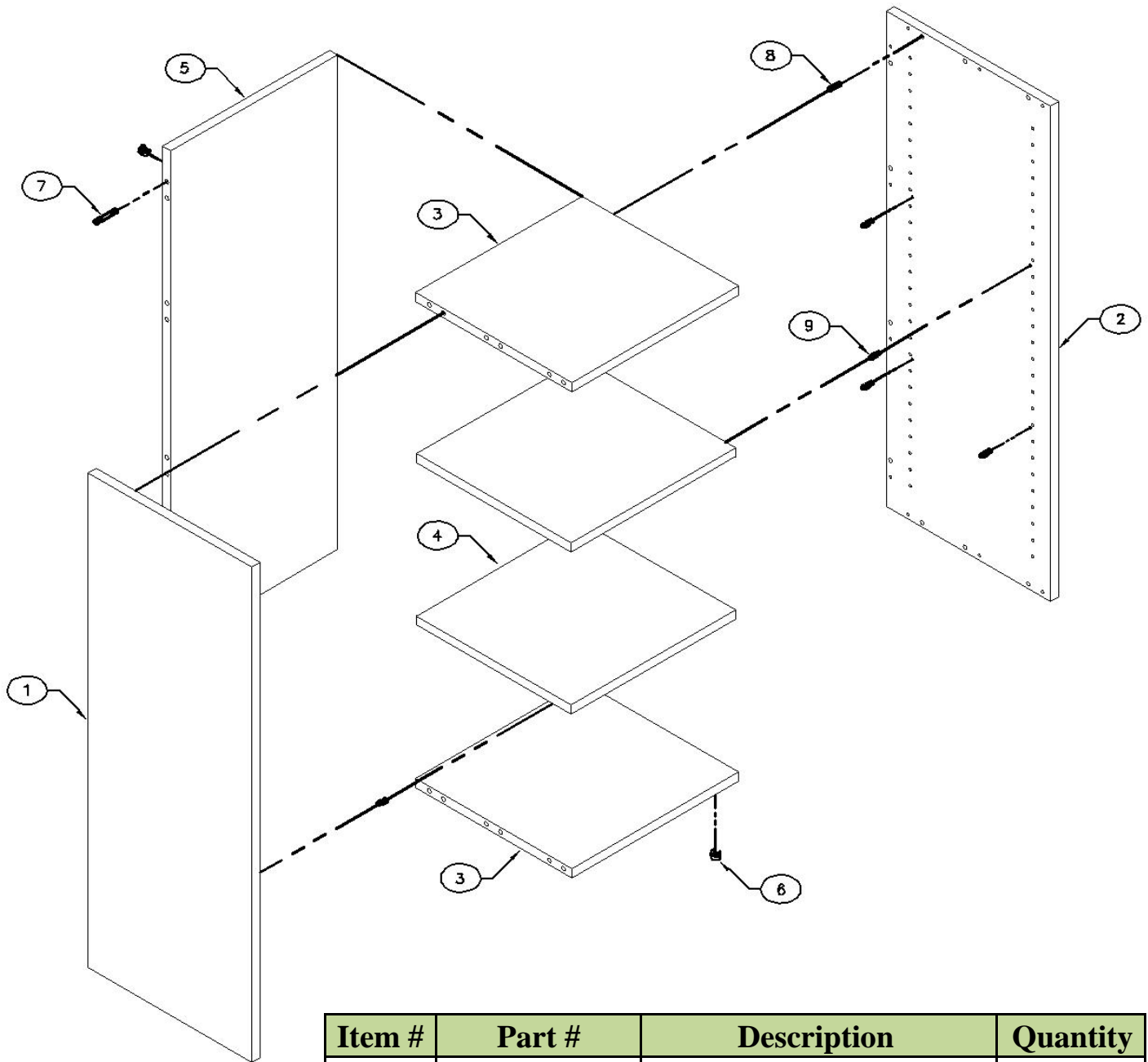

Item #	Part #	Description	Quantity
1	ISA80013	Left End Panel	1
2	ISA80015	Right End Panel	1
3	ISA80017	Top & Bottom Panel	2
4	ISA80021	Shelf Panel	2
5	ISA80025	Back Panel	1

Integrate Assembly Instructions
Upper Shelving Unit 16" Open
(Part No. I16USO)

6.



CTR21541: Cam Locks

7.

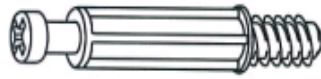

CTR21504: Bolts

8.



DWL0027: Dowel 1 Inch

9.



PIN4000: Shelf Pin

Your Final Assembled Product should look like below (Based on the Ordered Configuration)

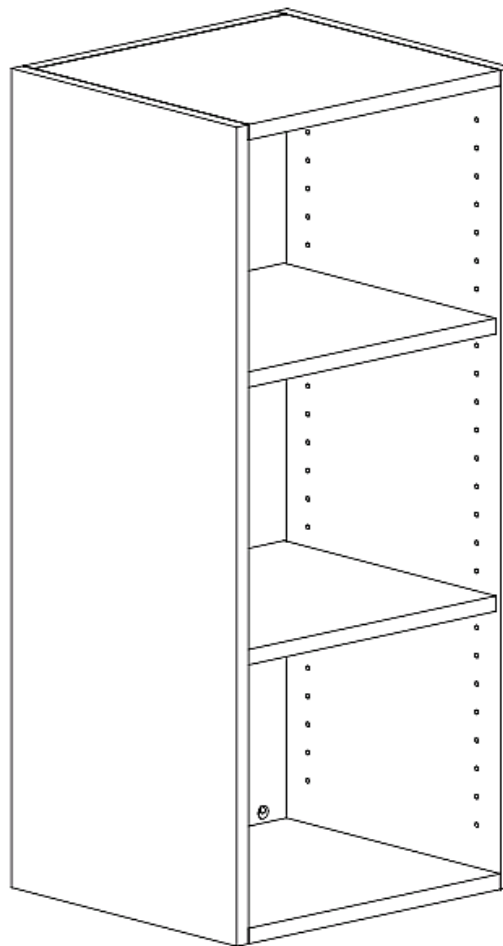

REF DWG# ITG130800-07

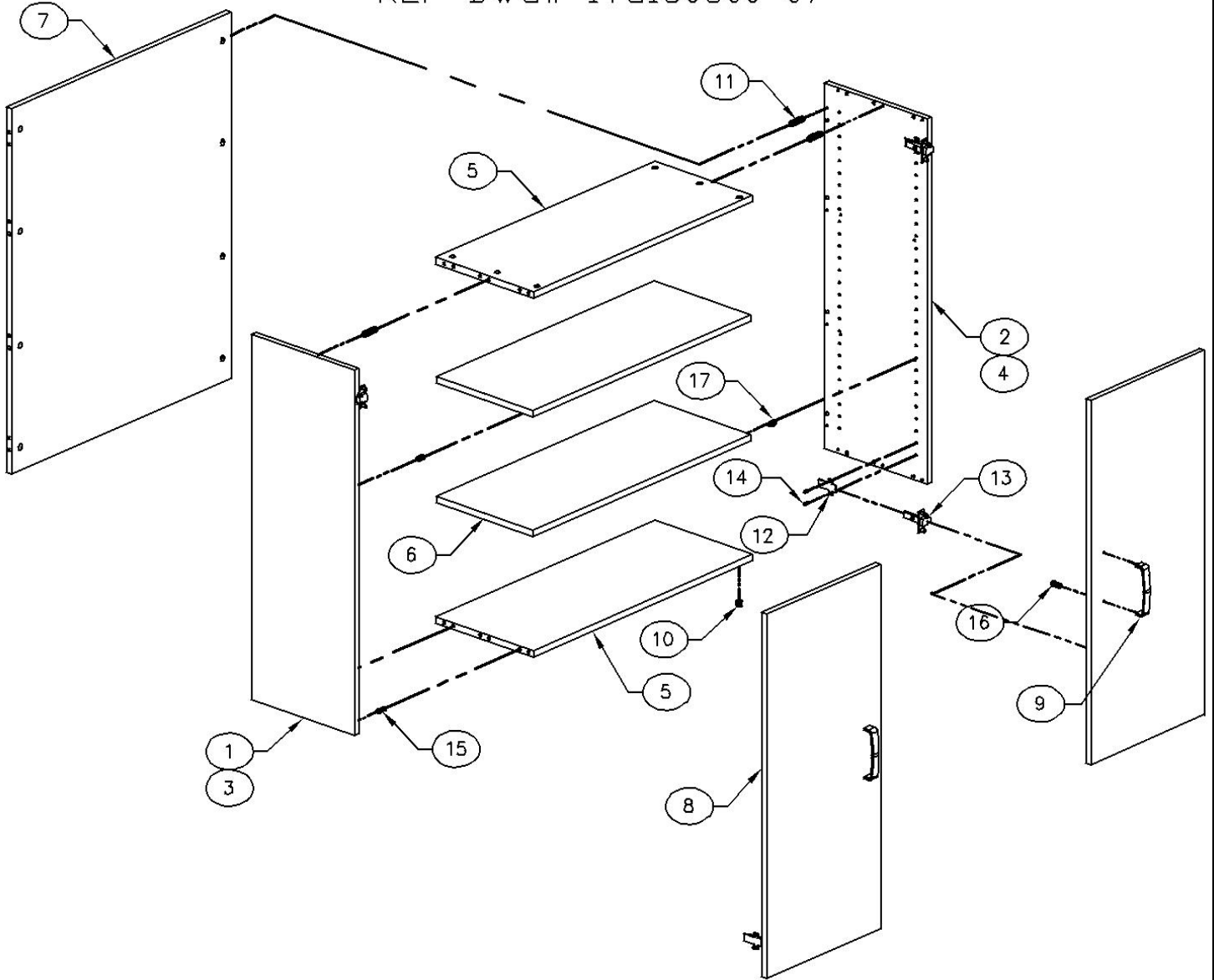

Item #	Part #	Description	Quantity
1 & 3	ISA80009	Left End Panel & Hardware	1
2 & 4	ISA80011	Right End Panel & Hardware	1
5	ISA80019	Top & Bottom Panel	2
6	ISA80023	Shelf Panel	2
7	ISA80027	Back Panel	1
8	ISA80031	Door Panel	2

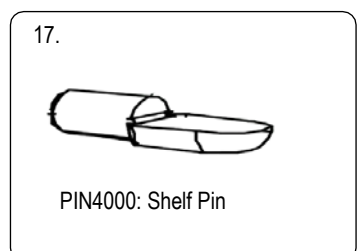
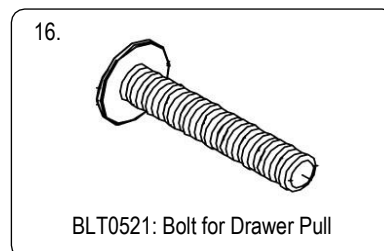
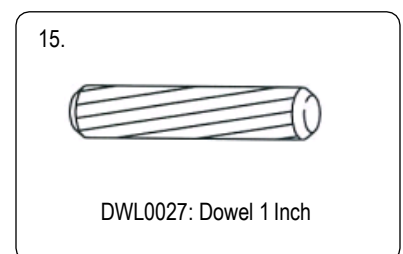
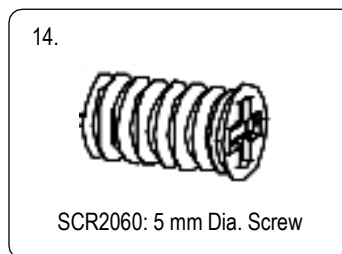
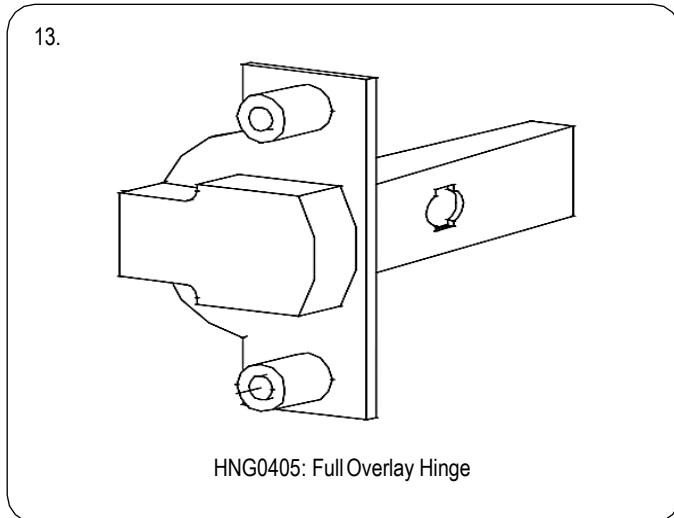
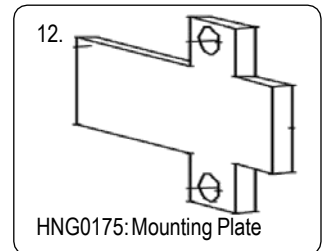
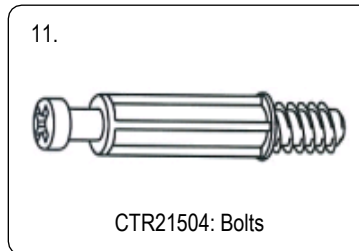
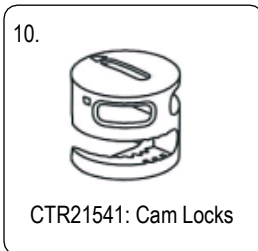
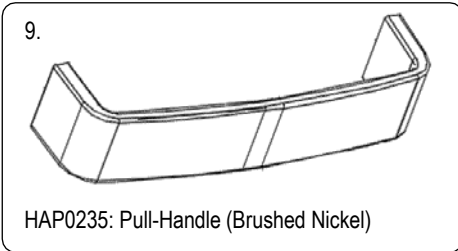

Your Final Assembled Product should look like below

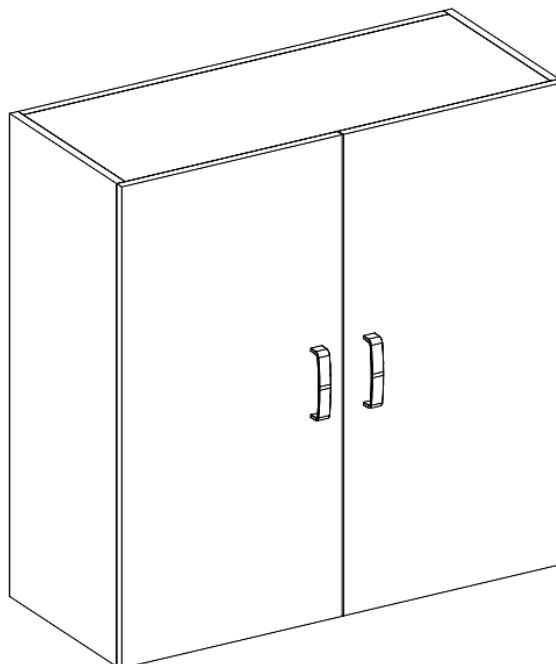

Integrate Assembly Instructions
Upper Shelving Unit 36" Open
(Part No. I36USO)

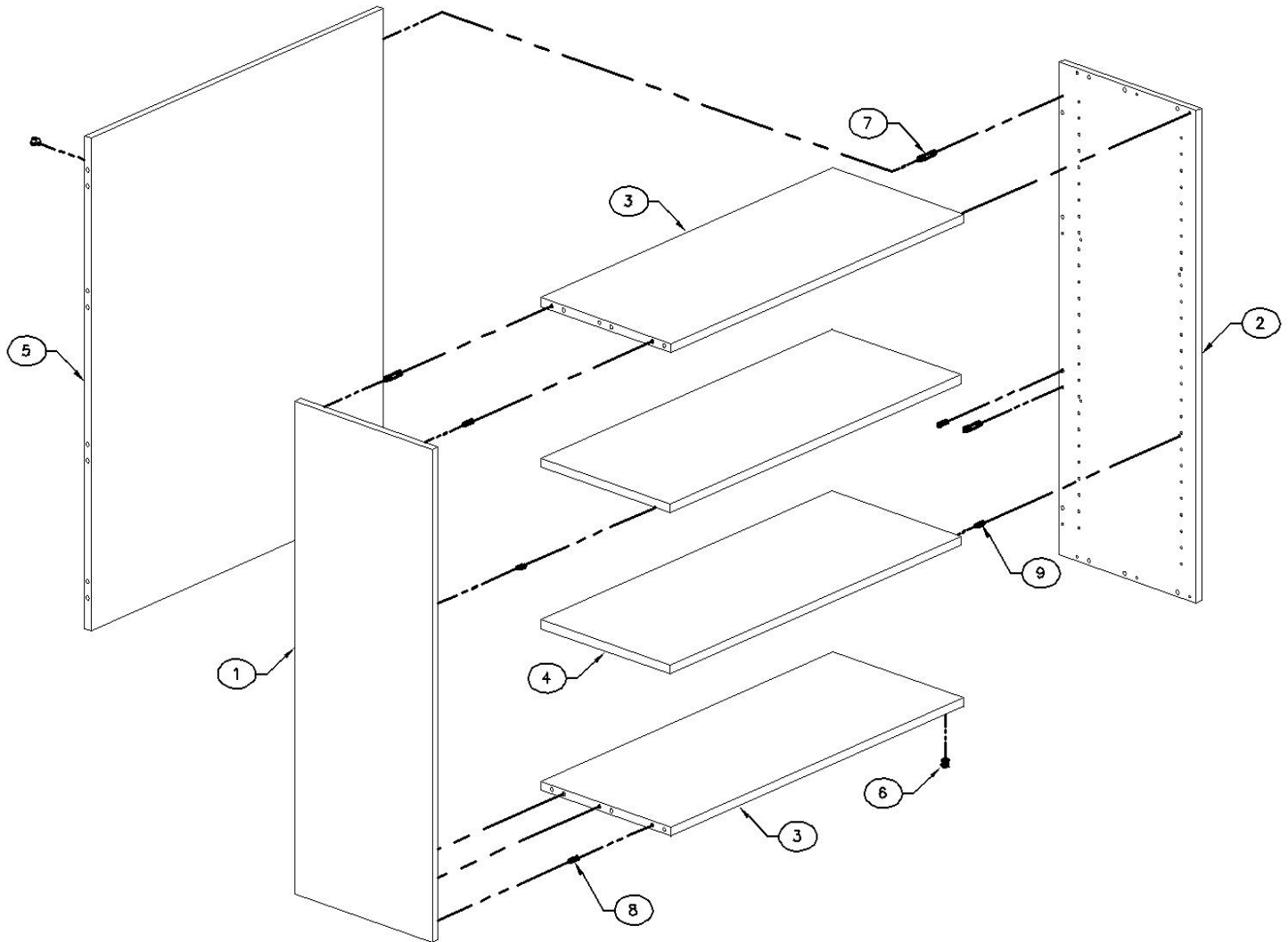

Item #	Part #	Description	Quantity
1	ISA80013	Left End Panel	1
2	ISA80015	Right End Panel	1
3	ISA80019	Top & Bottom Panel	2
4	ISA80023	Shelf Panel	2
5	ISA80027	Back Panel	1

Integrate Assembly Instructions
Upper Shelving Unit 36" Open
(Part No. I36USO)

6.



CTR21541: Cam Locks

7.



CTR21504: Bolts

8.



DWL0027: Dowel 1 Inch

9.



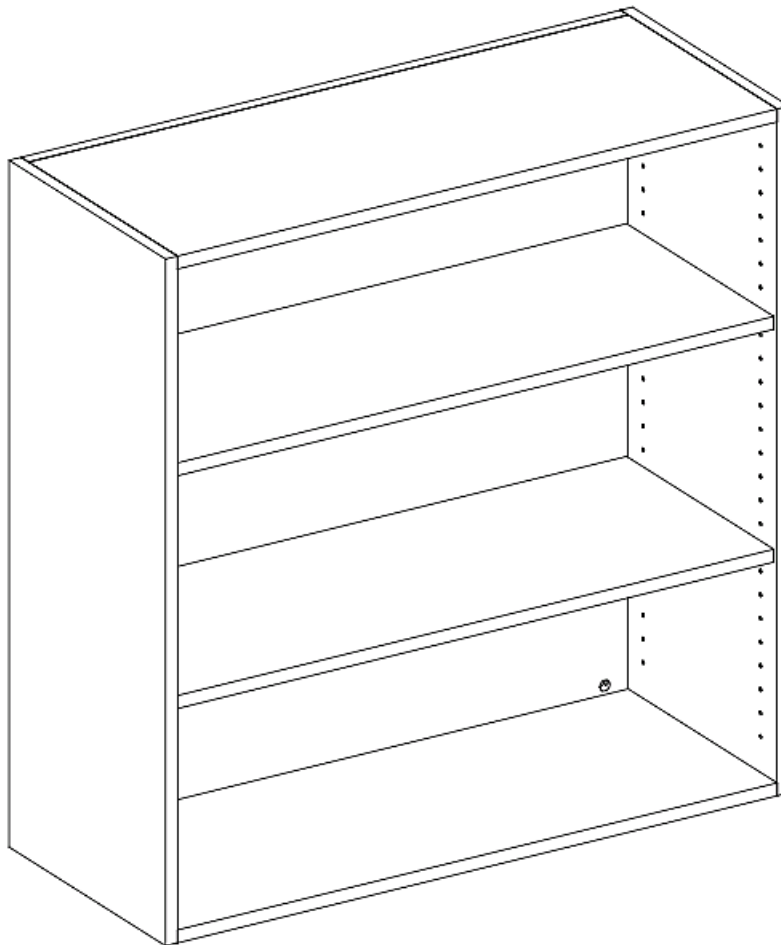

PIN4000: Shelf Pin

Your Final Assembled Product should look like below



Integrate Assembly Instructions
Compact Wardrobe
(Part No. I1854WR)

Note

-  1 Mount Toe Kick flush with top of Bottom Panel
-  2 Space Brackets Evenly on the front and back edge of Bottom Panel
-  3 Locate Top Panel flush with Top, Outside edge of Back panels.

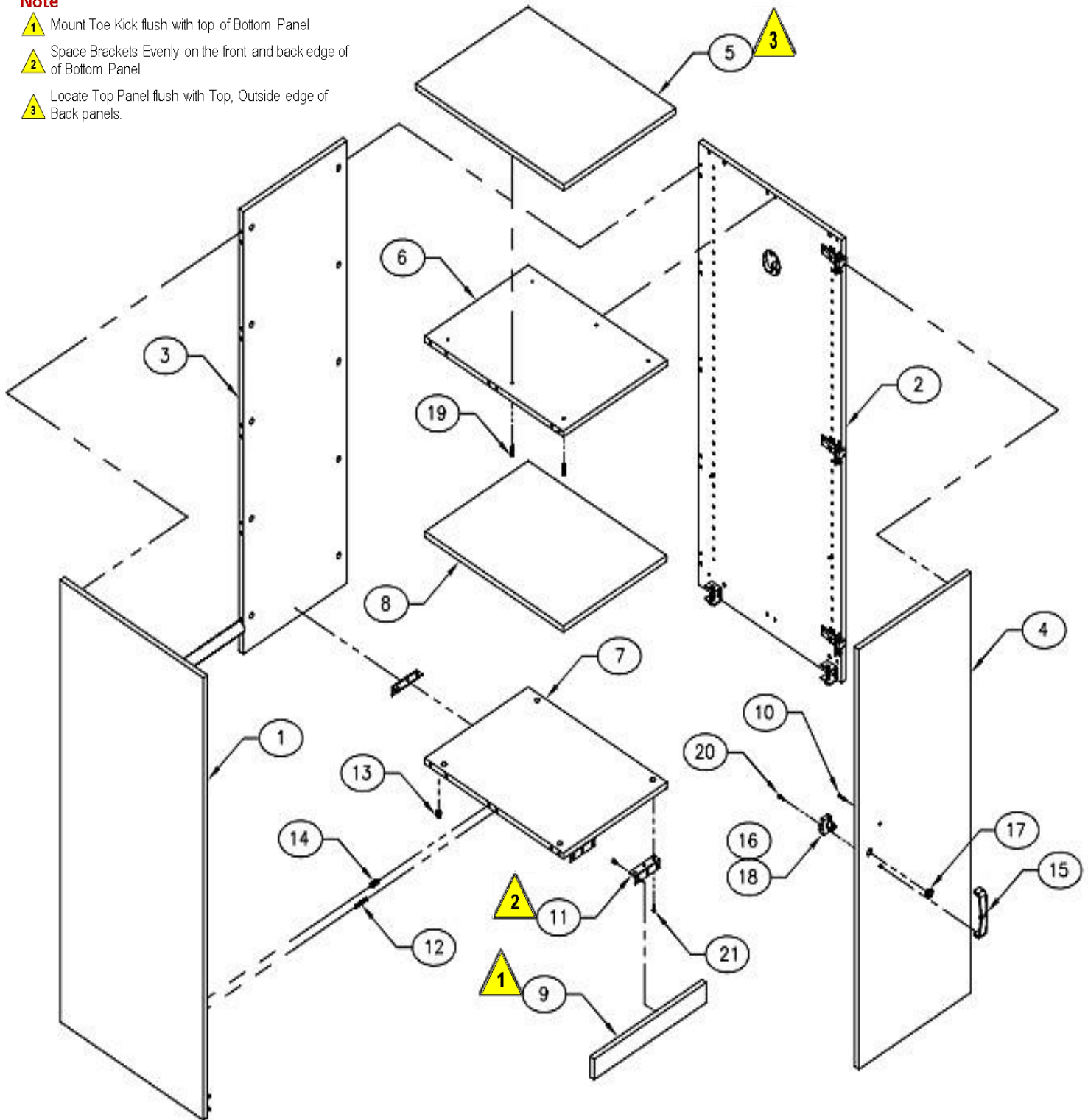

Item #	Part #	Description	Quantity
1	ISA110105	Left End Panel Subassembly	1
2	ISA110109	Right End Panel Subassembly	1
3	ISA110119	Back Panel	1
4	ISA110121	Door Panel	1
5	ISA110123	Top Panel	1
6	ISA110125	Top Interior Panel	1
7	ISA110033	Bottom Panel	1
8	ISA110037	Shelf Panel	1
9	ISA110039	Toe Kick Panel	1

10.



BLT0521: Bolt for Drawer Pull

11.

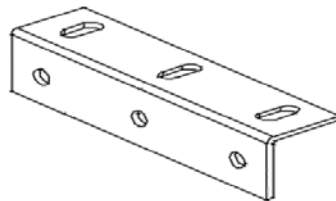

BRB0441: Steel Cleats

12.

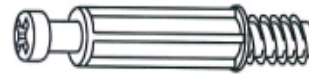

CTR21504: Bolts

13.



CTR21541: Cam Locks

14.



DWL0027: Dowel 1 Inch

15.

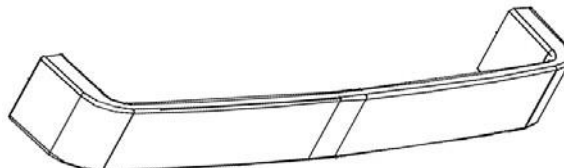

HAP0235: Pull-Handle (Brushed Nickel)

16 & 18.

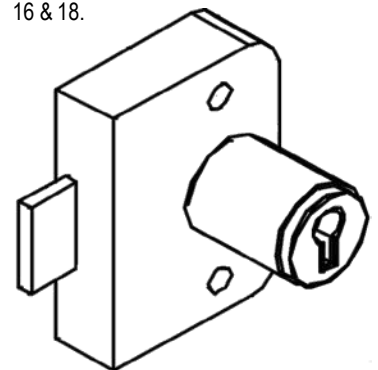

LOX0100: Lock Assembly &
LOX323: Lock Core

17.

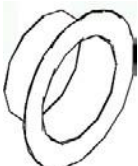

LOX0150: Lock-Bezel

19.



SCR0677: 1-1/4 Inch
Screw

20.

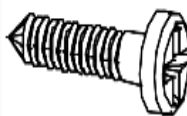

SCR9404: #6, .625
Screw

21.



SCR2507: 5/8" Screw

Compact Wardrobe Right Panel Assembly (ISA110109)

3.

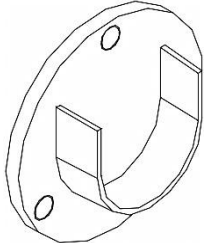

FLG0011BN :Open End For Clothes

4.

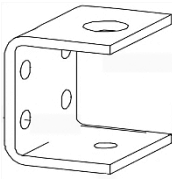

GLI0301: Zinc Plated Gusset

Rod 5.

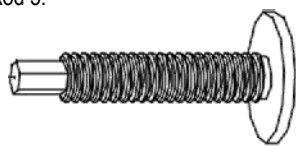

GLI0211: Hex-Tip Leveler

6.

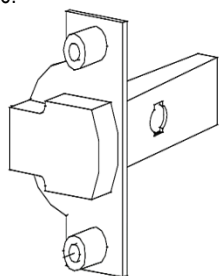

HNG0405: Full Overlay Hinge

7.

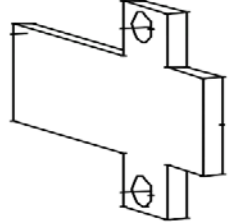

HNG0175: Mounting Plate

8.

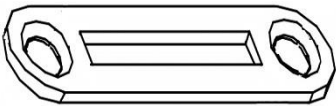

LOX0128: Strike Plate

9.



PIN4000: Shelf Pin

10.



SCR9404: #5, 0.5" Screw

11.



SCR2060: 5 mm Dia. Screw

12.

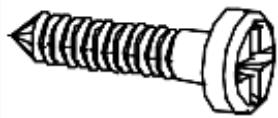

SCR2507: 5/8" Screw

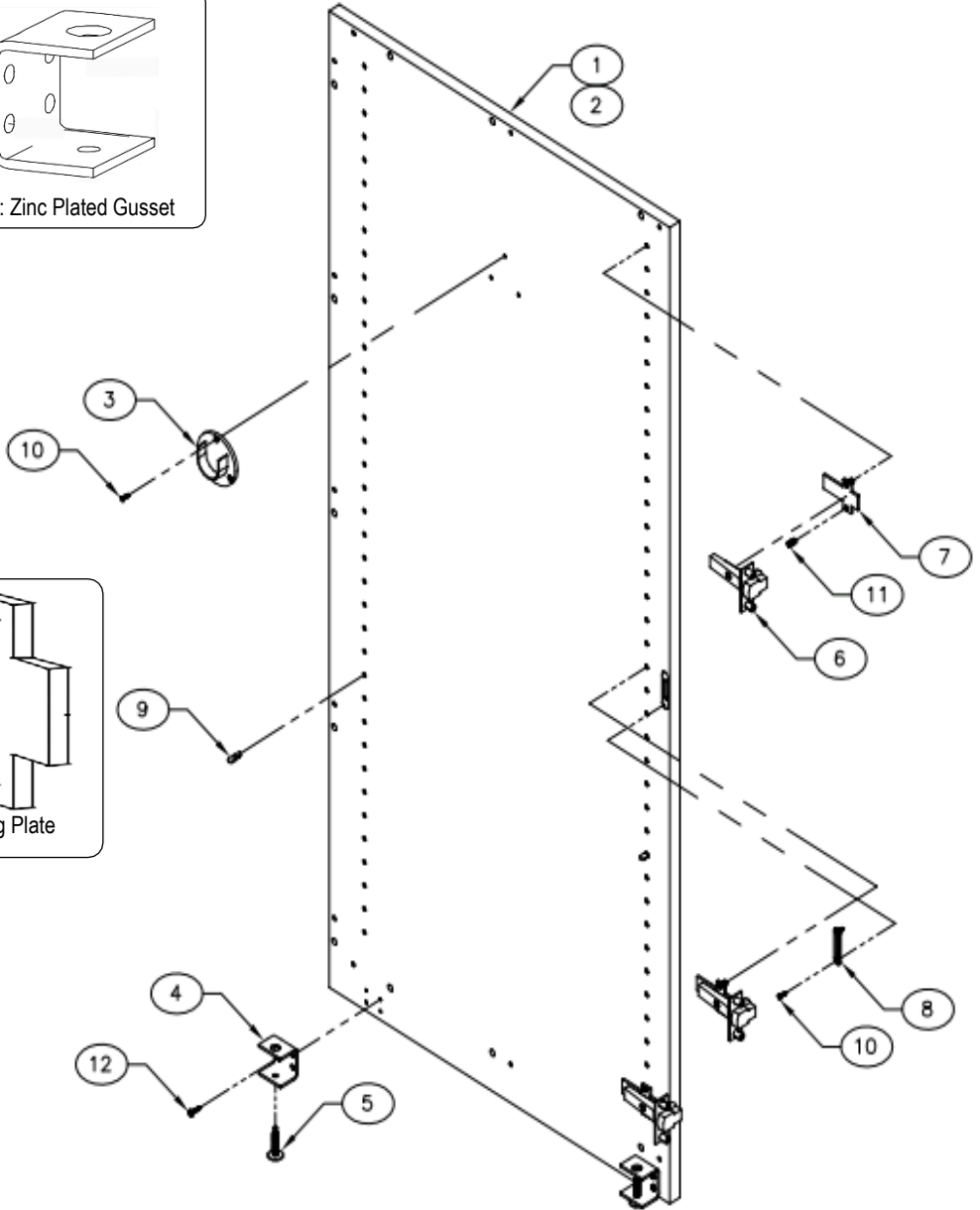

Compact Wardrobe Left Panel Assembly (ISA110105)

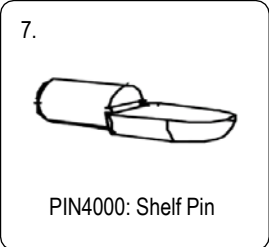
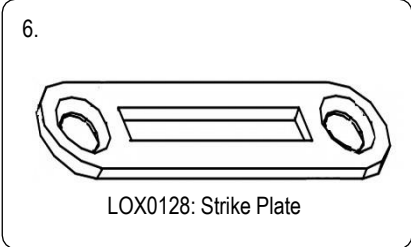
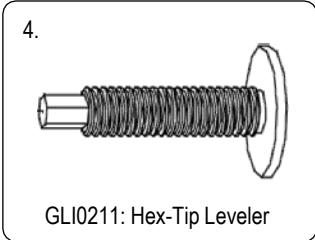
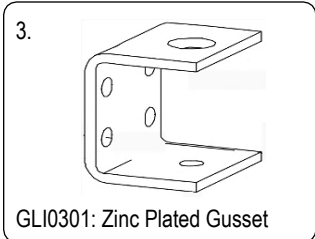
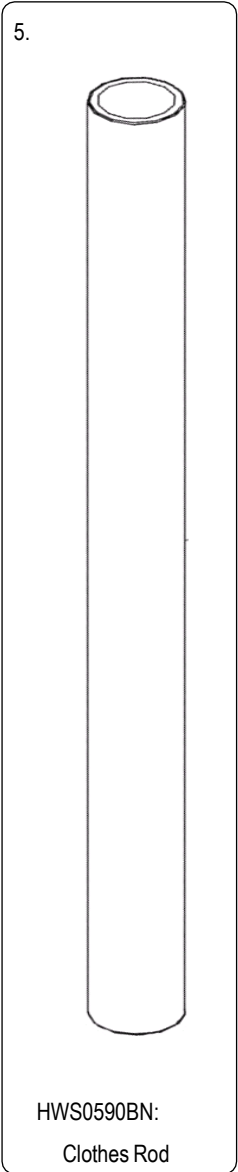
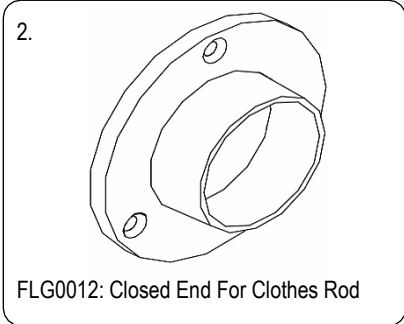
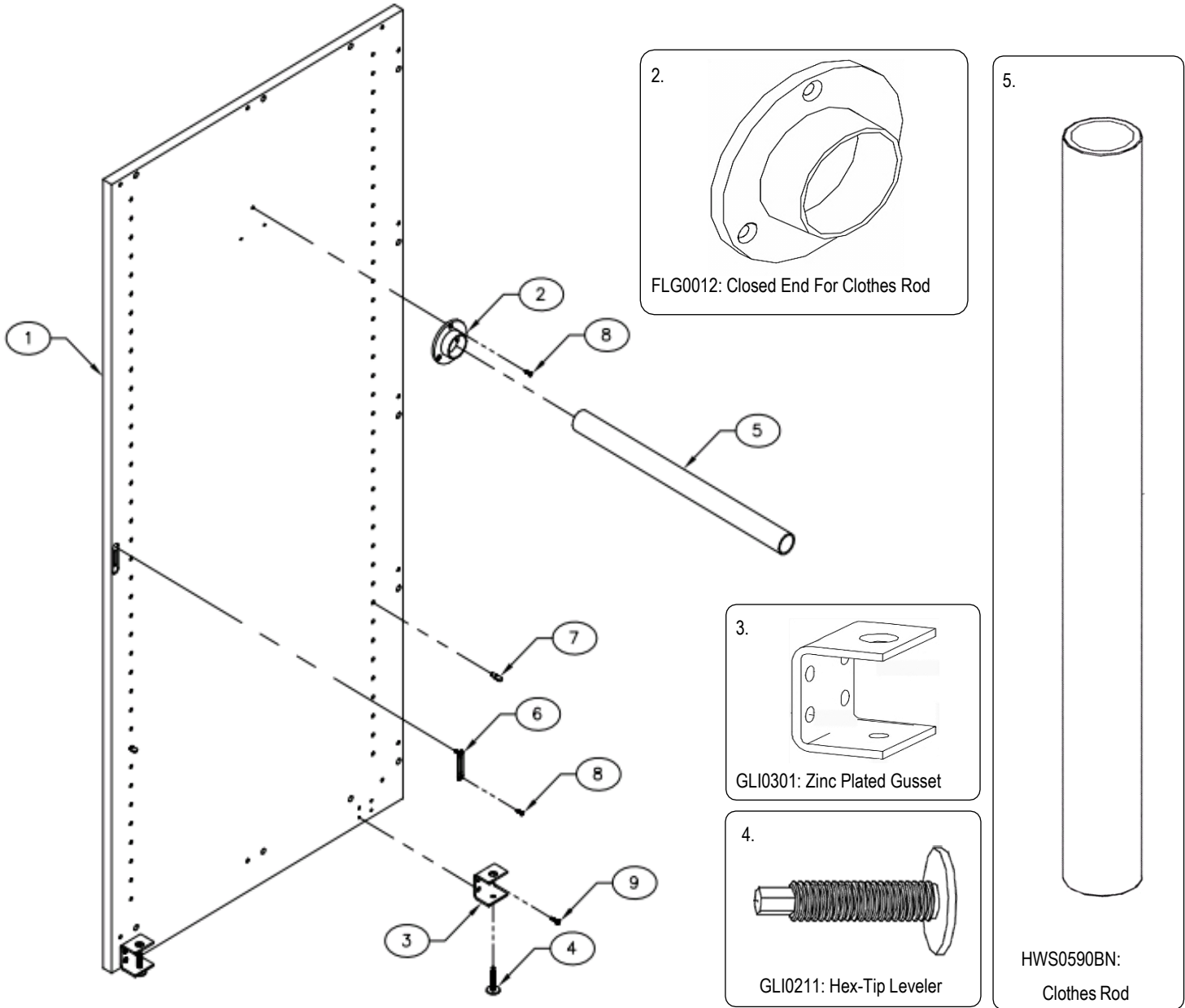

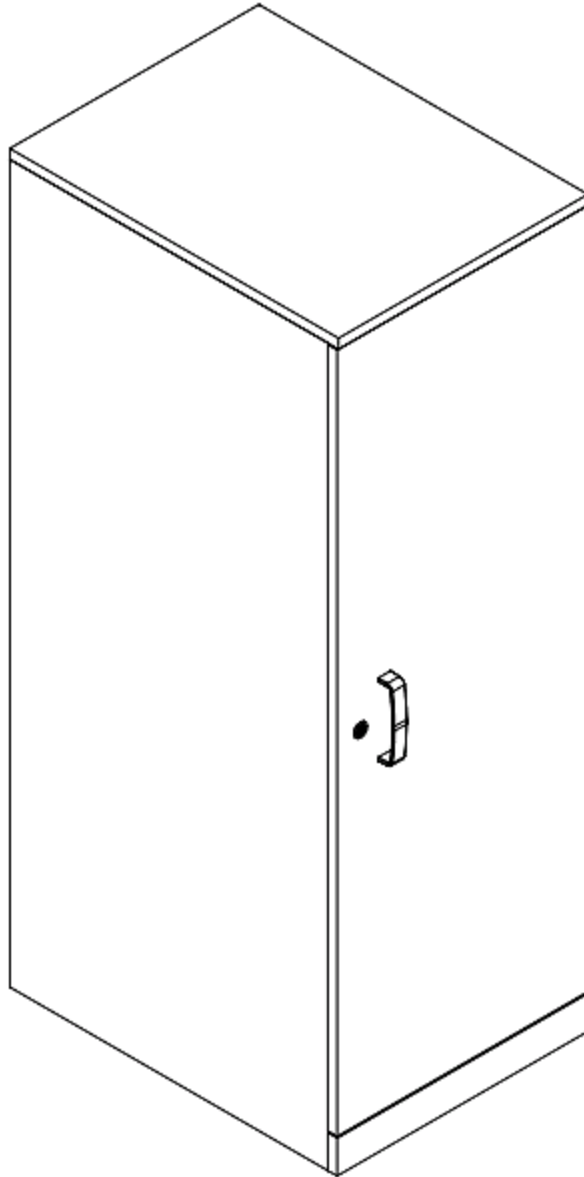

Integrate Assembly Instructions
Compact Wardrobe
(Part No. I1854WR)

Your Final Assembled Product should look like below



Note

-  Mount Toe-Kick flush with top of Bottom Panel
-  Space Cleats evenly on the front and the back edge of Bottom Panel

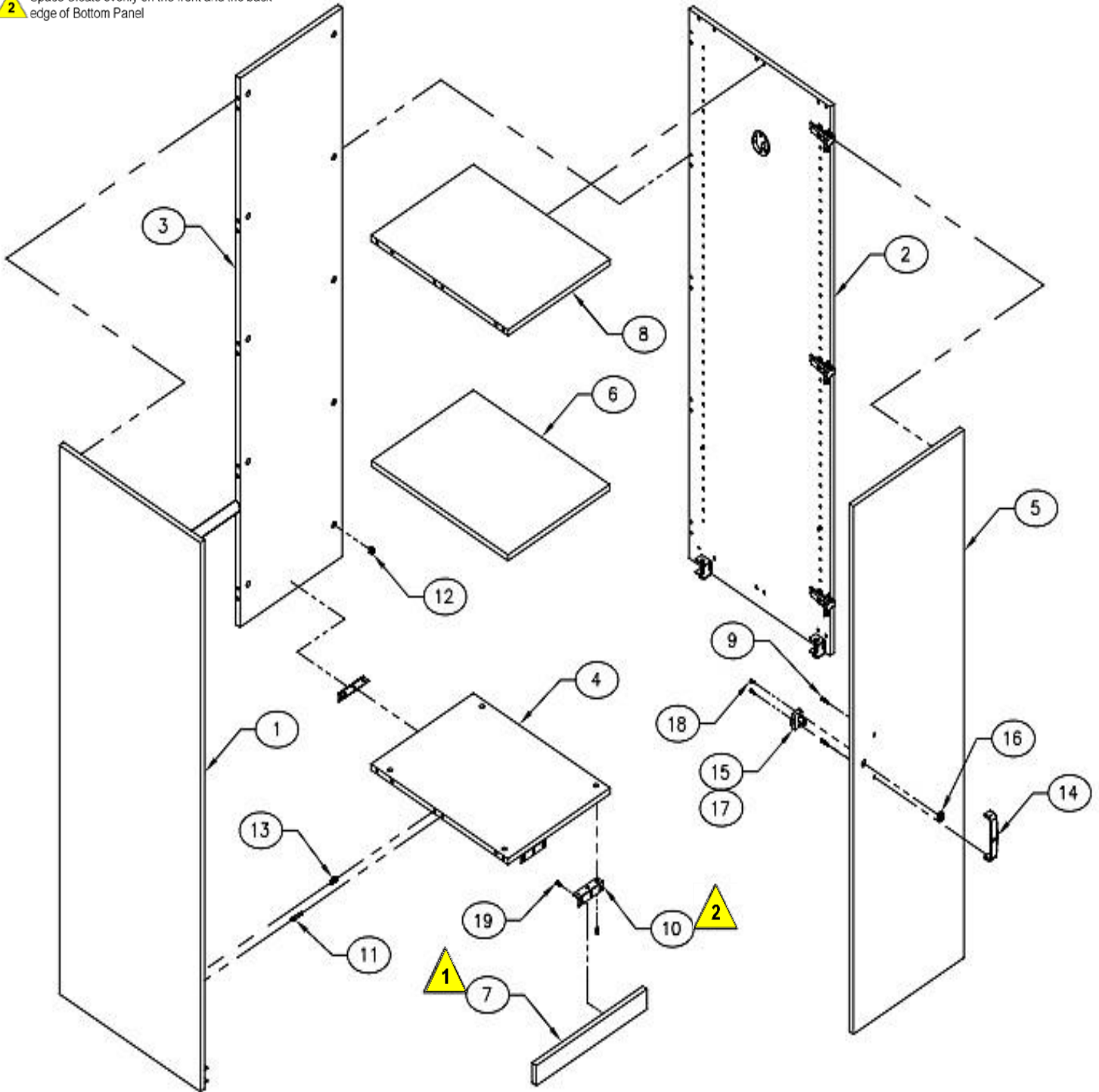

Item #	Part #	Description	Quantity
1	ISA110009	Left End Panel Subassembly	1
2	ISA110013	Right End Panel Subassembly	1
3	ISA110031	Back Panel	1
4	ISA110033	Bottom Panel	1
5	ISA110035	Door Panel	1
6	ISA110037	Shelf Panel	1
7	ISA110039	Toe Kick Panel	1
8	ISA110041	Top Interior Panel	1

9.

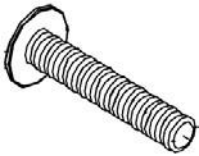

BLT0521: Bolt for Drawer Pull

10.

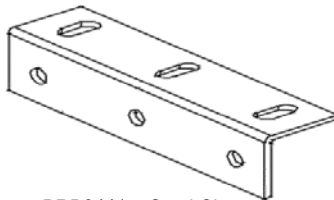

BRB0441: Steel Cleats

11.

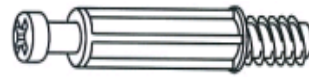

CTR21504: Bolts

12.



CTR21541: Cam Locks

13.



DWL0027: Dowel 1 Inch

14.

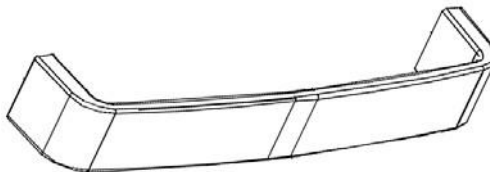

HAP0235: Pull-Handle (Brushed Nickel)

15 & 17.

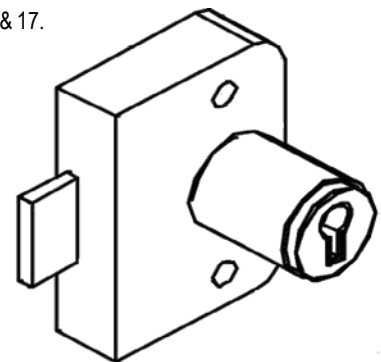

LOX0100: Lock Assembly &
LOX323: Lock Core

16.

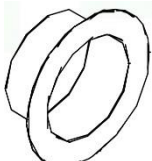

LOX0150: Lock-Bezel

18.

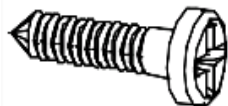

SCR9404: #6, .625 Screw

19.



SCR2507: 5/8" Screw

Standard Wardrobe Right Panel Assembly (ISA110013)

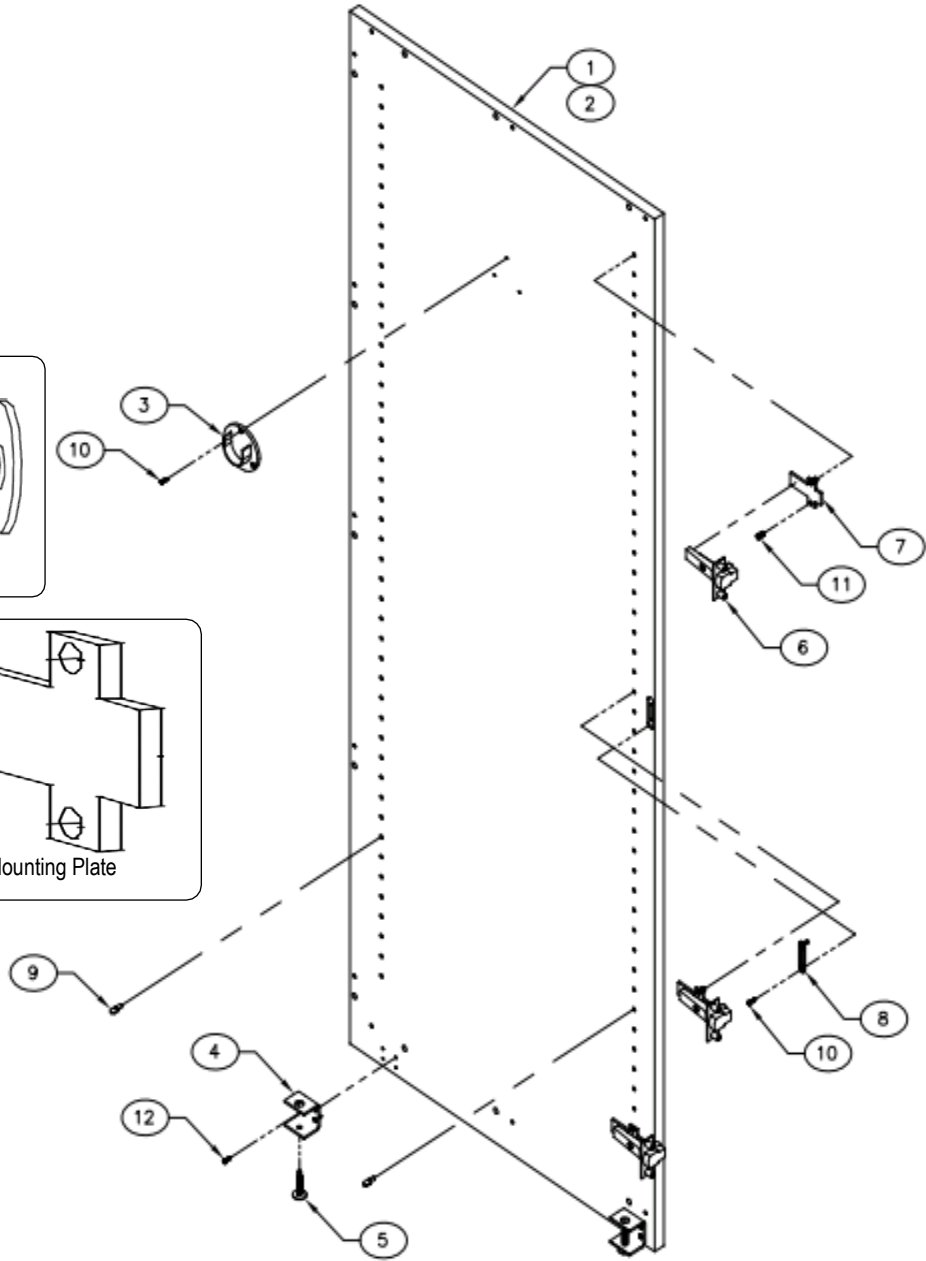
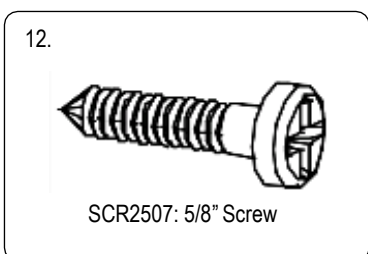
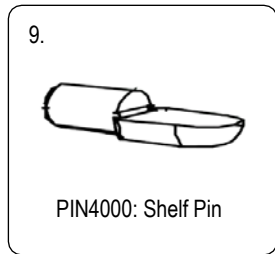
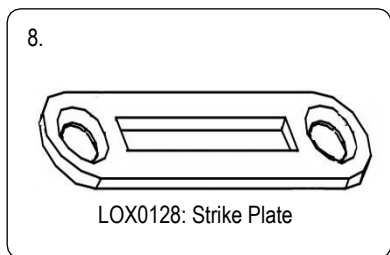
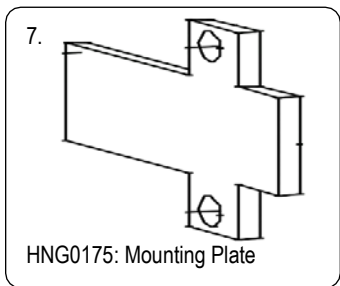
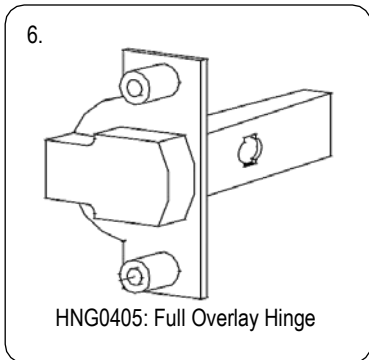
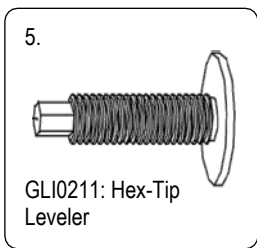
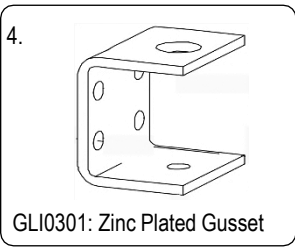
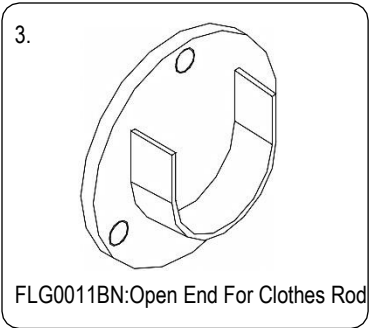

Integrate Assembly Instructions
Standard Wardrobe
(Part No. I1867WR)

Standard Wardrobe Left Panel Assembly (ISA110009)

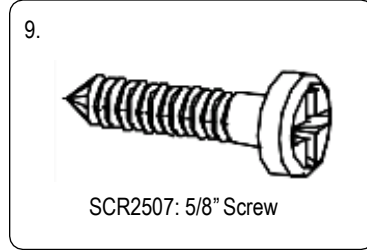
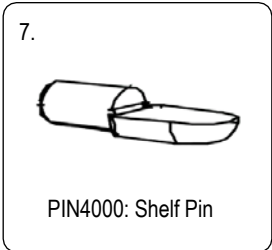
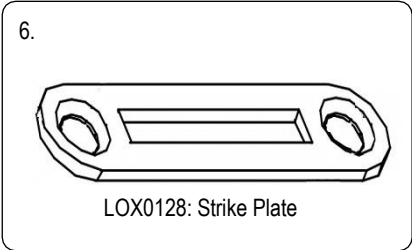
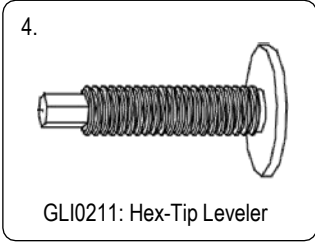
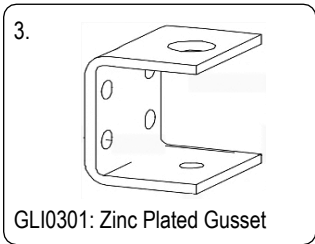
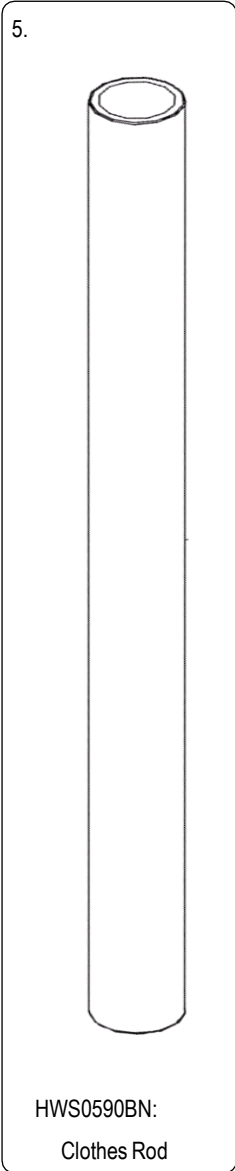
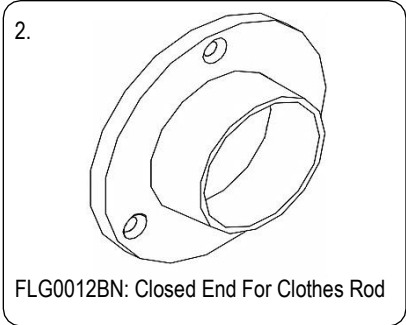
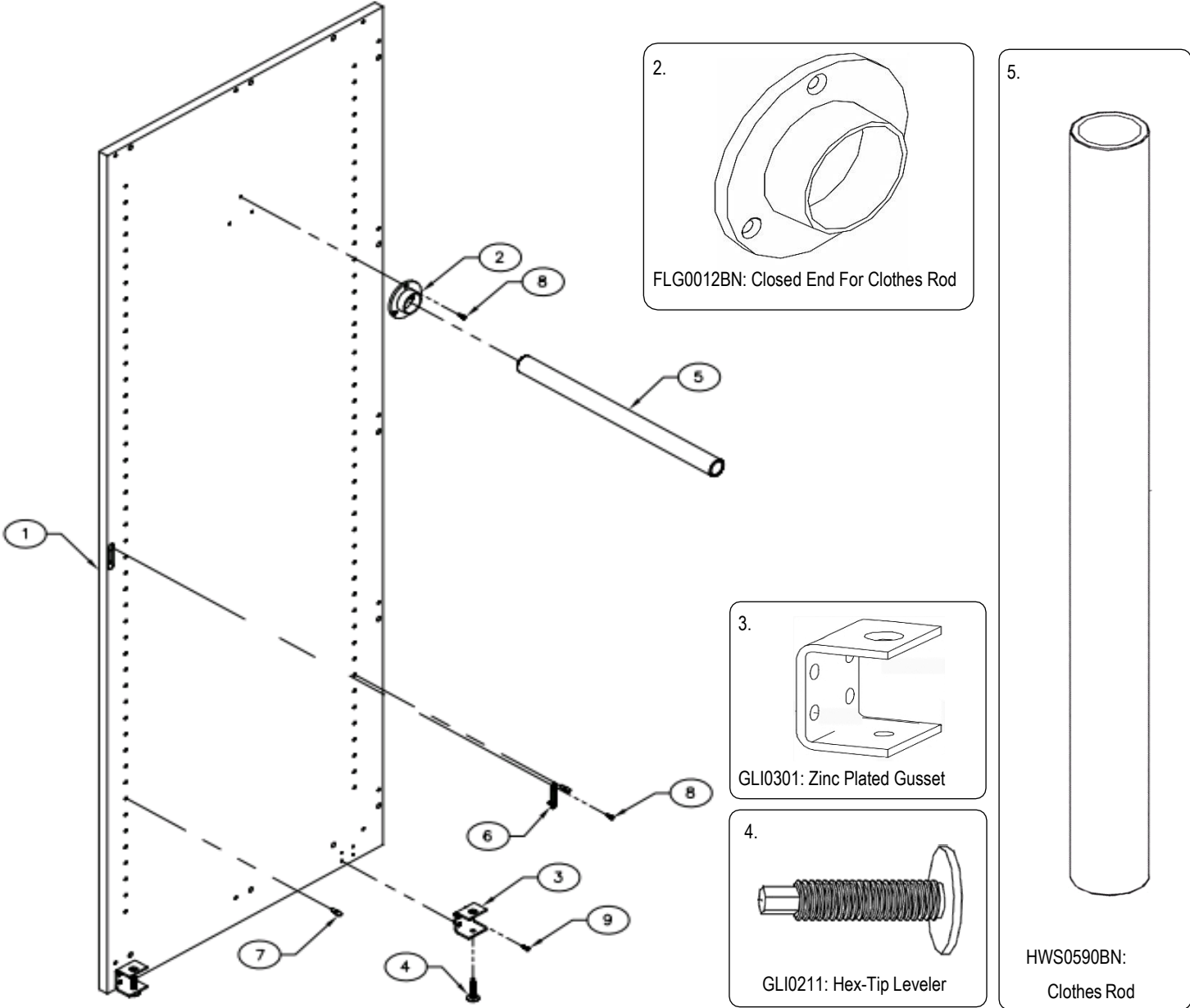

Integrate Assembly Instructions
Standard Wardrobe
(Part No. I1867WR)

Your Final Assembled Product should look like below

