



## Crescendo Planning Guide

03.2017



## Table of Contents

General Information	Introduction .....	2
Product Overview	Panel Preconfigurations .....	4
	Stackable Sections .....	8
	Door Components .....	9
	Intersection Conditions .....	10
	Wall Mount Components .....	14
	Stackable Intersections .....	14
	Panel Components .....	16
	Worksurface Accessories .....	19
	Overhead Storage/Accessories .....	24
	Lights .....	26
	Markerboards .....	26
	Tackboards .....	26
	Paper Management/Accessories .....	27
Planning Guidelines	Panel Support and Loading .....	28
	Storage Units .....	31
	Panel Mounting Guidelines .....	32
	Weight Capacities .....	33
	Wall Mounting .....	34
	Stacking Section Guidelines .....	36
	Door Guidelines .....	37
	Reconfiguring Panels .....	39
	Electrical Power .....	50
	Data Cable Management .....	65
Crescendo Technical Specifications	Panels .....	73
	Panel Trim and Accessories .....	75
	Electrical .....	76
	Worksurfaces and Accessories .....	77
	Overhead Storage and Accessories .....	78
	Paper Management Accessories .....	79
	Typical Workstation Configurations .....	80

---

# Crescendo

## Introduction

The Crescendo Panel System is completely modular in nature, designed for office environments that require frequent reconfiguration. The modularity of Crescendo panels stems from separate frame, tile, and trim systems that assemble entirely with only a rubber mallet. A screwdriver and wrench are required to assemble overheads and install worksurfaces. A pre-wired power system can be run in the modular units at four standard heights. Hundreds of data cables can be managed throughout the panel system. Crescendo accommodates all standard types of cables. Crescendo also supports OFG's Modular Data System.

The Crescendo frame is simple to assemble and disassemble since it is based on only four basic parts (the full vertical post, half vertical post, corner connector block, and horizontal rail). Horizontal rails are designed to be added and removed without disturbing the vertical posts or power/data cables managed throughout the system. All cables are laid into the system without threading through the frame to greatly enhance the ability to reconfigure the system with minimal disruption and downtime. Vertical posts can later be stacked one on top of another to easily change panel height.

Panels come in three different styles to offer the user complete control over the office environment. Monolithic, segmented, and stackable styles are based on the same basic parts so they can easily be mixed and matched to maximize flexibility and value. Tiles are available in tackable acoustical fabric, tackable high-performance acoustical fabric, upholstered raceway, glass and open styles. Segmented and stackable panels can be any combination of these styles. Monolithic panels provide power inside of the base raceway. Segmented or stackable panels allow power at base, ADA, worksurface, and standing height. Storage accessories on monolithic panels are hung "on-module" using the slots in the vertical posts. Segmented or stackable panels can accommodate these accessories both "on-module" as well as "off-module", allowing overheads and panels of different widths to be used together and moved horizontally with minimal effort.

Crescendo is the essence of modularity and reconfiguration simplicity in today's ever changing office environment.

# Introduction

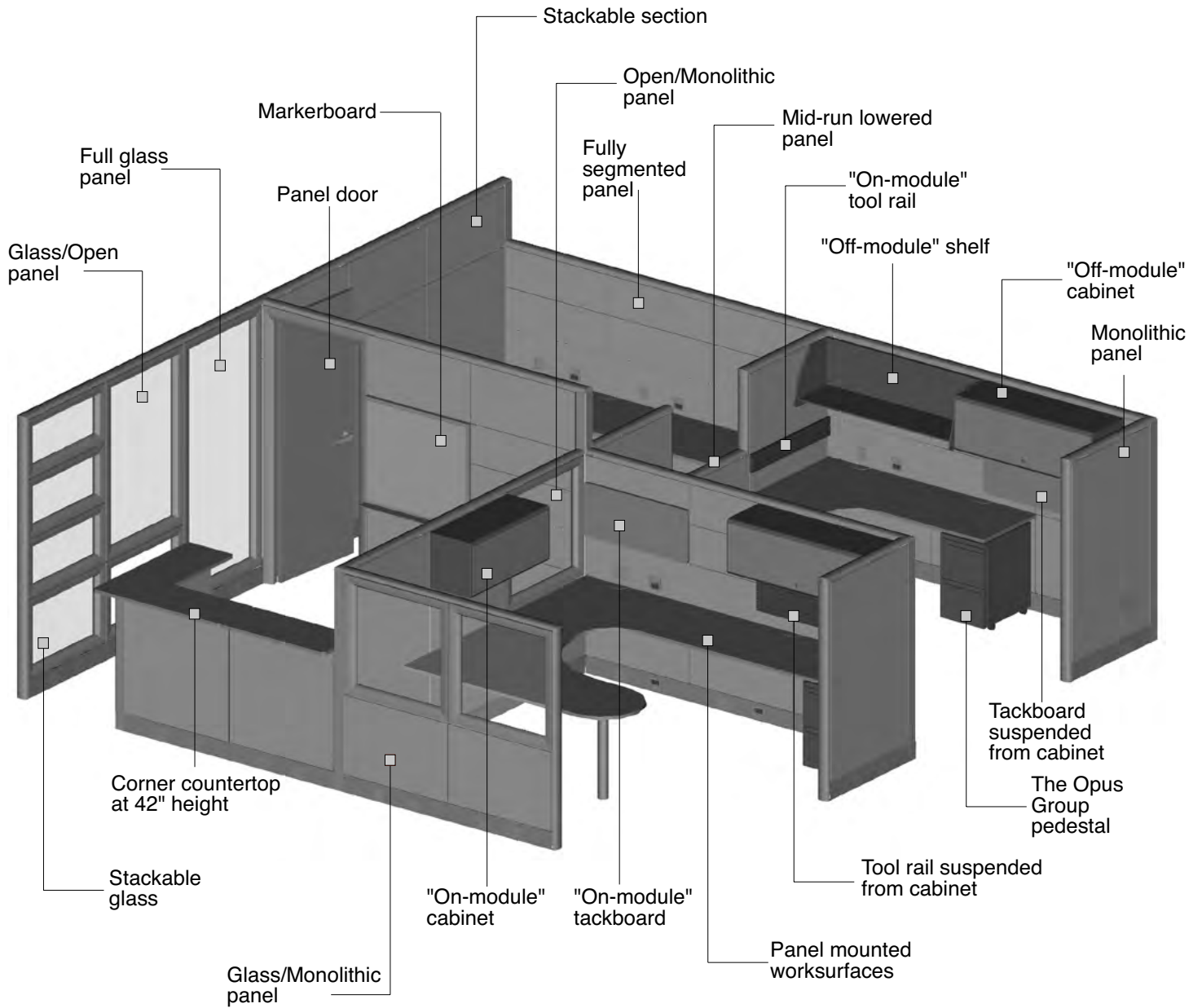

# Crescendo

## Product Overview

### PANEL PRECONFIGURATIONS Fabric Panels

#### Face Style: Monolithic

Basic Model: CCMMA & CCMMH  
Monolithic panels consist of full fabric tiles on both sides and a 6" base with base power available. Tiles are field replaceable. Panel also includes horizontal rails, top cap, and top cap sleeve. Acoustic or highly acoustic.

**Width: 12", 18", 24", 30", 36", 42", 48", 54", 60"**

**Height: 30", 42", 54", 66", 84"**

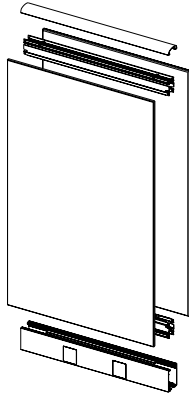

#### Face Style: Monolithic/Fully Segmented

Basic Model: CCMFA & CCMFH  
Monolithic/fully segmented panels consist of one full fabric side, one fully segmented side, and a 6" base with base power available. Fully segmented panels consist of 12" tiles. Quantity of 12" tiles is dependent upon panel height. 84" high panels include one 18" tile on top. Tiles are field replaceable. Panel also includes horizontal rails, top cap, and top cap sleeve. Acoustic or highly acoustic.

**Width: 12", 18", 24", 30", 36", 42", 48", 54", 60"**

**Height: 30", 42", 54", 66", 84"**

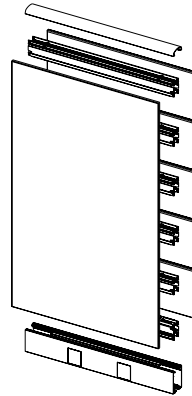

#### Face Style: Monolithic/Half Segmented

Basic Model: CCMHA & CCMHH  
Monolithic/half segmented panels consist of one full fabric side, one half segmented side, and a 6" base with base power available. Half segmented panels consist of 24" fabric tile on bottom and tiles in 12" increments. Quantity of 12" tiles is dependent upon panel height. 84" high panels include one 18" tile on top. Tiles are field replaceable. Panel also includes horizontal rails, top cap, and top cap sleeve. Acoustic or highly acoustic.

**Width: 12", 18", 24", 30", 36", 42", 48", 54", 60"**

**Height: 42", 54", 66", 84"**

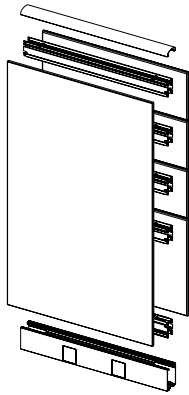

#### Face Style: Half Segmented/Half Segmented

Basic Model: CCHHA & CCHHH  
Half segmented/half segmented panels consist of two half segmented sides and a 6" base with base power available. Half segmented panels consist of 24" fabric tile on bottom and tiles in 12" increments on top. Quantity of 12" tiles is dependent upon panel height. 84" high panels include one 18" tile on top. Tiles are field replaceable. Panel also includes horizontal rails, top cap, and top cap sleeve. Acoustic or highly acoustic.

**Width: 12", 18", 24", 30", 36", 42", 48", 54", 60"**

**Height: 42", 54", 66", 84"**

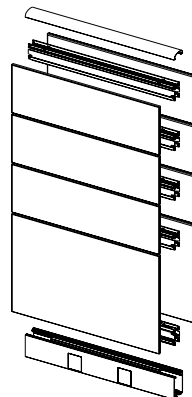

**NOTE: For all panels, assembled panel heights are a minimum of 1-5/8" taller than standard heights.**

## Product Overview

### Face Style: Half Segmented/Fully Segmented

Basic Model: CCHFA & CCHFH

Half segmented/fully segmented panels consist of one half segmented side, one fully segmented, and a 6" base with base power available. Half segmented panels consist of 24" fabric tile on bottom and tiles in 12" increments. Fully segmented panels consist of 12" tiles. Quantity of 12" tiles is dependent upon panel height. 84" high panels include one 18" tile on top. Tiles are field replaceable. Panel also includes horizontal rails, top cap, and top cap sleeve. Acoustic or highly acoustic.

**Width:** 12", 18", 24", 30", 36", 42", 48", 54", 60"

**Height:** 42", 54", 66", 84"

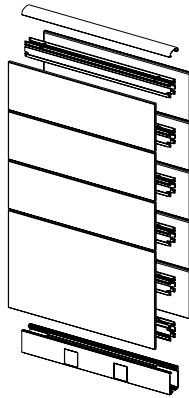

### Face Style: Fully Segmented/Fully Segmented

Basic Model: CCFFA & CCFH

Fully segmented/fully segmented panels consist of two fully segmented sides and a 6" base with base power available. Fully segmented panels consist of 12" tiles. Quantity of 12" tiles is dependent upon panel height. 84" high panels include one 18" tile on top. Tiles are field replaceable. Panel also includes horizontal rails, top cap, and top cap sleeve. Acoustic or highly acoustic.

**Width:** 12", 18", 24", 30", 36", 42", 48", 54", 60"

**Height:** 30", 42", 54", 66", 84"

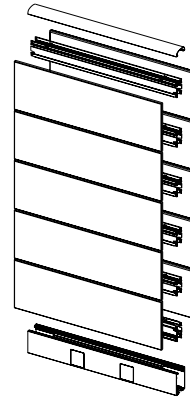

## PANEL PRECONFIGURATIONS Glass Panels

### Face Style: Full Glass

Basic Model: CCG

Full glass panels consist of a full height glass tile and 6" base with base power available. Panel also includes horizontal rails, top cap, and top cap sleeve.

**Width:** 12", 18", 24", 30", 36", 42", 48"

**Height:** 54", 66", 84"

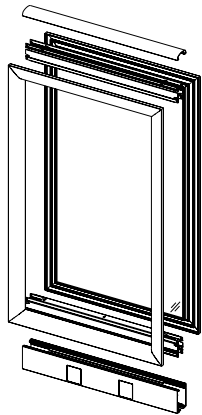

### Face Style: Monolithic/Glass

Basic Model: CCMMGA & CCMMGH

Glass/monolithic panels consist of 24" fabric tile on bottom of both sides and remainder of panel is glass. Base is 6" with base power available. Tiles are field replaceable. Panel also includes horizontal rails, top cap, and top cap sleeve. Acoustic or highly acoustic.

**Width:** 12", 18", 24", 30", 36", 42", 48"

**Height:** 54", 66", 84"

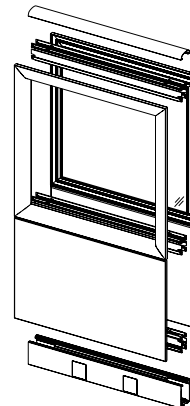

# Crescendo

## Product Overview

### PANEL PRECONFIGURATIONS Glass Panels

#### Face Style: Monolithic/Fully Segmented/ Glass

Basic Model: CCMFGA & CCMFGH

Glass/monolithic and fully segmented panels consist of a 24" tile on bottom of one side and two 12" tiles on bottom of other side; remainder of panel is glass. Base is 6" with base power available. Tiles are field replaceable. Panel also includes horizontal rails, top cap, and top cap sleeve. Acoustic or highly acoustic.

**Width: 12", 18", 24", 30", 36", 42", 48"**

**Height: 54", 66", 84"**

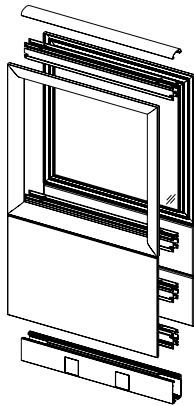

#### Face Style: Fully Segmented/Glass

Basic Model: CCFFGA & CCFFGH

Glass/fully segmented panels consist of two 12" tiles on bottom of both sides; remainder of panel is glass. Base is 6" with base power available. Tiles are field replaceable. Panel also includes horizontal rails, top cap, and top cap sleeve. Acoustic or highly acoustic.

**Width: 12", 18", 24", 30", 36", 42", 48"**

**Height: 54", 66", 84"**

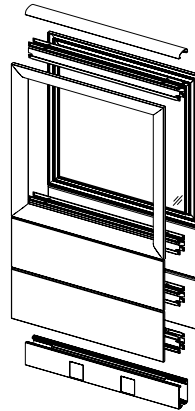

### PANEL PRECONFIGURATIONS Open & Open/Glass Panels

#### Face Style: Fully Open

Basic Model: CCO

Fully open panels consist of a full height open tile. Base is 6" with base power available. Panel also includes horizontal rails, top cap, and top cap sleeve.

**Width: 12", 18", 24", 30", 36", 42", 48"**

**Height: 30", 42", 54", 66", 84"**

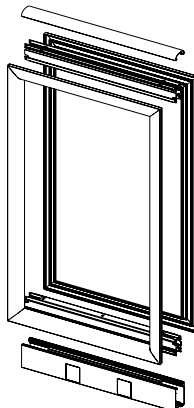

#### Face Style: Open/Monolithic

Basic Model: CCOMMA & CCOMMH

Open/monolithic panels consist of 24" open tile on bottom; remainder of panel is a single fabric tile on both sides. Base is 6" with base power available. Tiles are field replaceable. Panel also includes horizontal rails, top cap, and top cap sleeve. Acoustic or highly acoustic.

**Width: 12", 18", 24", 30", 36", 42", 48"**

**Height: 42", 54", 66", 84"**

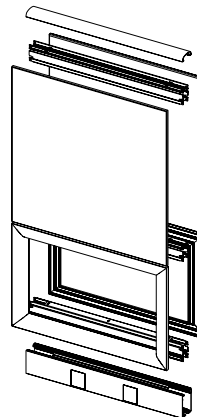



## Product Overview

### Face Style: Open/Monolithic and Fully Segmented

Basic Model: CCOMFA & CCOMFH

Open/monolithic and fully segmented panels consist of 24" open tile on bottom; remainder of panel is a single fabric tile on one side and fabric tiles in 12" increments on the other side. Quantity of 12" tiles is dependent upon panel height. 84" high panels include one 18" tile. Base is 6" with base power available. Tiles are field replaceable. Panel also includes horizontal rails, top cap, and top cap sleeve. Acoustic or highly acoustic.

**Width:** 12", 18", 24", 30", 36", 42", 48"  
**Height:** 54", 66", 84"

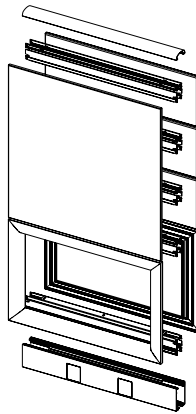

### Face Style: Monolithic/Open Panels

Basic Model: CCMMOA & CCMMOH

Monolithic/open panels consist of 24" fabric tile on bottom on both sides and open tile on top. Base is 6" with base power available. Tiles are field replaceable. Panel also includes horizontal rails, top cap, and top cap sleeve. Acoustic or highly acoustic.

**Width:** 12", 18", 24", 30", 36", 42", 48"  
**Height:** 42", 54", 66", 84"

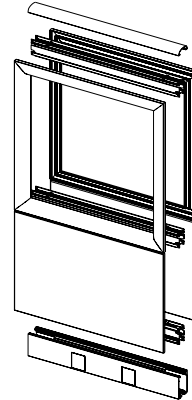

### Face Style: Open/Fully Segmented

Basic Model: CCOFFA & CCOFFH

Open/fully segmented panels consist of 24" open tile on bottom; remainder of panel is fabric tiles in 12" increments on both sides. Quantity of 12" tiles is dependent upon panel height. 84" high panels include one 18" tile. Base is 6" with base power available. Tiles are field replaceable. Panel also includes horizontal rails, top cap, and top cap sleeve. Acoustic or highly acoustic.

**Width:** 12", 18", 24", 30", 36", 42", 48"  
**Height:** 54", 66", 84"

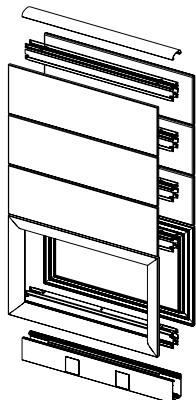

### Face Style: Monolithic and Fully Segmented/Open

Basic Model: CCMFOA & CCMFOH

Monolithic and fully segmented/open panels consist of a 24" fabric tile on one side of bottom, two 12" tiles on the other side of bottom; remainder of panel is open tile. Base is 6" with base power available. Tiles are field replaceable. Panel also includes horizontal rails, top cap, and top cap sleeve. Acoustic or highly acoustic.

**Width:** 12", 18", 24", 30", 36", 42", 48"  
**Height:** 42", 54", 66", 84"

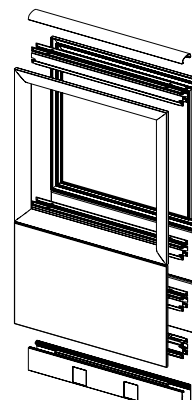

# Crescendo

## Product Overview

### PANEL PRECONFIGURATIONS Open & Open/Glass Panels

#### Face Style: Fully Segmented/Open

Basic Model: CCFFOA & CCFFOH  
Fully segmented/open panels consist of two 12" fabric tiles on bottom of both sides; remainder of panel is an open tile. Base is 6" with base power available. Tiles are field replaceable. Panel also includes horizontal rails, top cap, and top cap sleeve. Acoustic or highly acoustic.

**Width: 12", 18", 24", 30", 36", 42", 48"**

**Height: 42", 54", 66", 84"**

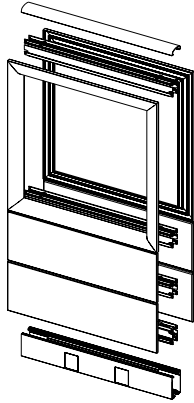

#### Face Style: Open/Glass

Basic Model: CCOG  
Glass/open panels consist of 24" open tile on bottom; remainder of panel is glass. Base is 6" with base power available. Panel also includes horizontal rails, top cap, and top cap sleeve.

**Width: 12", 18", 24", 30", 36", 42", 48"**

**Height: 54", 66", 84"**

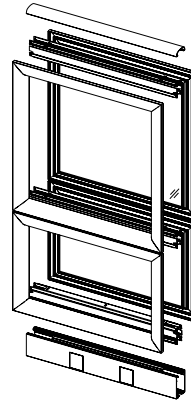

### STACKABLE SECTIONS

#### Acoustical Stackable Section

Basic Model: CCSA & CCSH  
Tackable tiles are mounted on vertical posts with super tough nylon hooks. Includes horizontal rail. Tiles are field replaceable. Acoustic or highly acoustic.

**Width: 12", 18", 24", 30", 36", 42", 48", 54", 60"**

**Height: 12", 18", 24"**



#### Open Stackable Section

Basic Model: CCSO  
Open tile is mounted on vertical posts with super tough nylon hooks. Includes horizontal rail. Tiles are field replaceable.

**Width: 12", 18", 24", 30", 36", 42", 48"**

**Height: 12", 18", 24"**

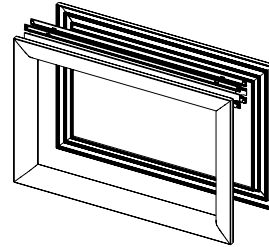

#### Glass Stackable Section

Basic Model: CCSG  
Full glass tile is mounted on vertical posts with super tough nylon hooks. Includes horizontal rail. Tiles are field replaceable. Acoustic or highly acoustic.

**Width: 12", 18", 24", 30", 36", 42", 48"**

**Height: 12", 18", 24"**

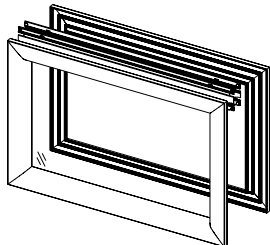

## Product Overview

### DOOR COMPONENTS

#### Door

Basic Model: CCDDR

Laminate surface on door. Locking and non-locking options. 42" door meets all ADA requirements.

Note: Door includes trim and horizontal rail. Vertical posts must be ordered separately. Doors must be ordered RH (Right Hand) or LH (Left Hand).

**Height: 80" door height (for 84" panel height)**

**Width: 36" opening (for 42" panel)**

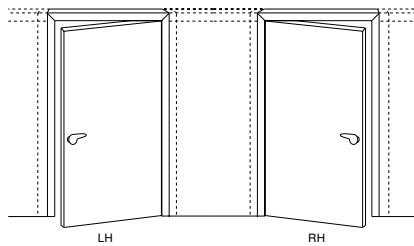

#### Door Threshold

Basic Model: CCDRTH

Extruded aluminum door threshold with rubber seal strip. Attaches to bottom of door frame.

**Width: 42" (used with 36" opening)**

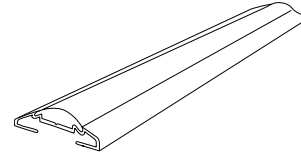

#### Rolling Screen

Basic Model: RSD

Provides non-locking visual security. Aluminum frame with clear or frosted (opal) fluted plastic core. Acrylic wheels allow ease of travel across flooring. Screen mounts to a 66" or higher panel and spans across a 42" opening. Frame and mounting brackets are powdercoated to match panel trim color.

**Height: 66" screen height (for 66" or taller panel height)**

**Width: 48" screen for a 42" opening**

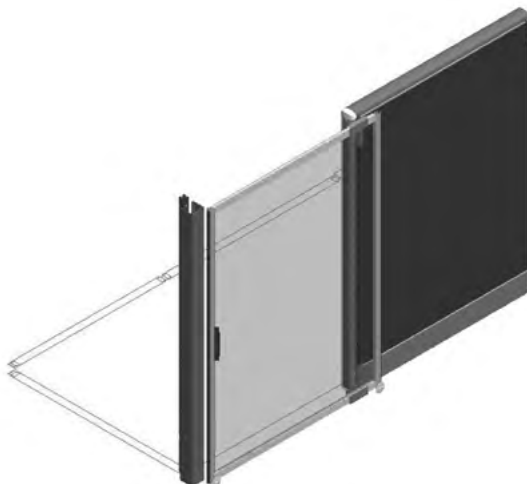

# Crescendo

## Product Overview

### INTERSECTION CONDITIONS

#### 180° 2-Way In-line Connection Both Panels Same Height

Basic Model: CCFP

Includes full post, light shield, and adjustable glide.

Heights: 30", 42", 54", 66", 84"

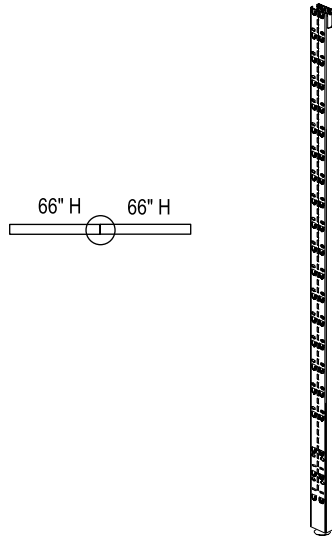

#### End-of-Run Condition

Basic Model: CCEP

Includes end-of-run trim, top cap, full-height post, light shield, and adjustable glide.

Heights: 30", 42", 54", 66", 84"

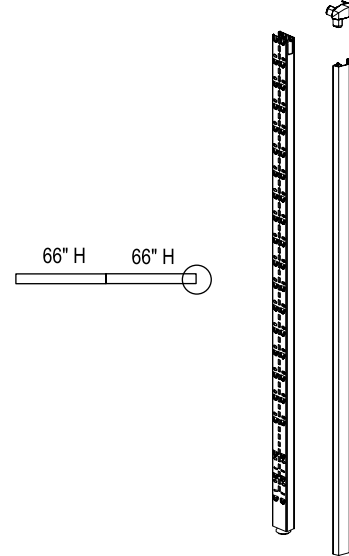

#### 180° In-line Connection Two Different Heights

Basic Model: CCFPV

Includes full post, in-line height change trim, in-line height change bottom cap, in-line height change top cap, light shield, and adjustable glide. Unupholstered only.

Heights: 30", 42", 54", 66", 84"

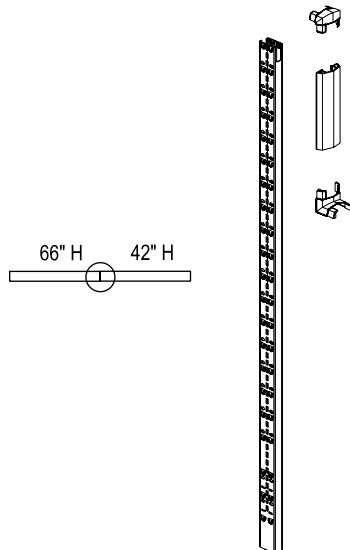

#### Off-Module Post

Basic Model: CCOMP

Includes off-module top trim end cap, off-module half post, light shield, and adjustable glide.

Heights: 30", 42", 54", 66", 84"

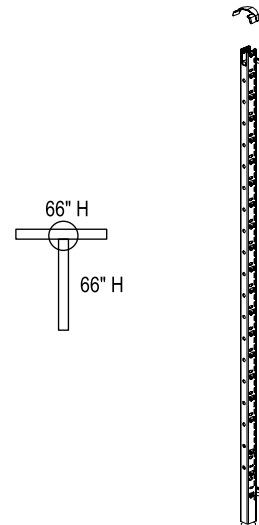

# Product Overview

## 90° 2-Way "L" Corner Both Panels Same Height

Basic Model: CCCP90 or CCCPF90  
Includes two half posts, 90° corner base, 90° top cap, hardware, universal trim, light shield, and adjustable glide. Unupholstered or upholstered.

Heights: 30", 42", 54", 66", 84"

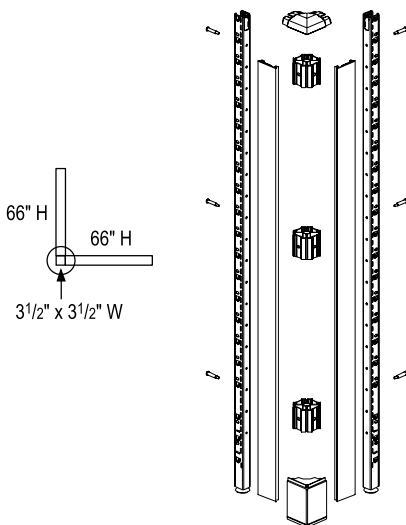

## 180° 2-Way In-line Spacer Two Different Heights

Basic Model: CCSPV180 or CCSPVF180  
Includes 3-way base, one way top cap, two half posts, hardware, universal trim, light shield, and adjustable glide. Unupholstered or upholstered.

Heights: 30", 42", 54", 66", 84"

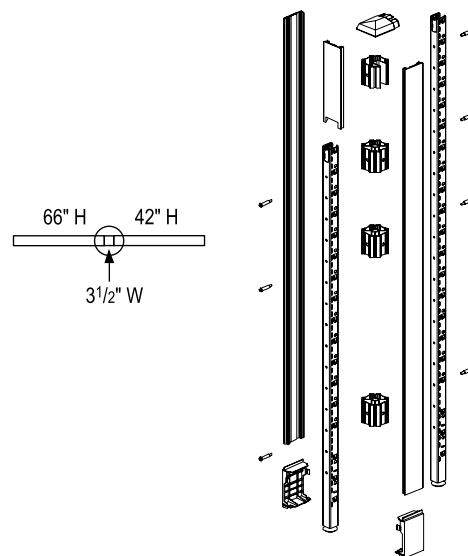

## 90° 2-Way "L" Corner Two Different Heights

Basic Model: CCCPV90 or CCCPVF90  
Includes one way top cap, 90° corner base, height change, two half posts, hardware, universal trim, light shield, and adjustable glide. Unupholstered or upholstered.

Heights: 30", 42", 54", 66", 84"

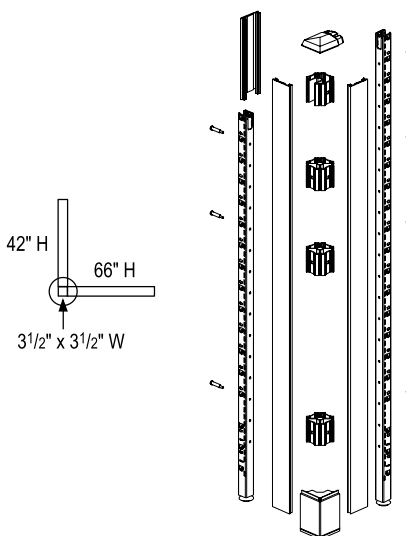

## 180° 2-Way In-line Spacer Both Panels Same Height

Basic Model: CCSP180 or CCSPF180  
Includes 180° top cap, 3-way trim & base, two half posts, hardware, universal trim, light shield, and adjustable glide. Unupholstered or upholstered.

Heights: 30", 42", 54", 66", 84"

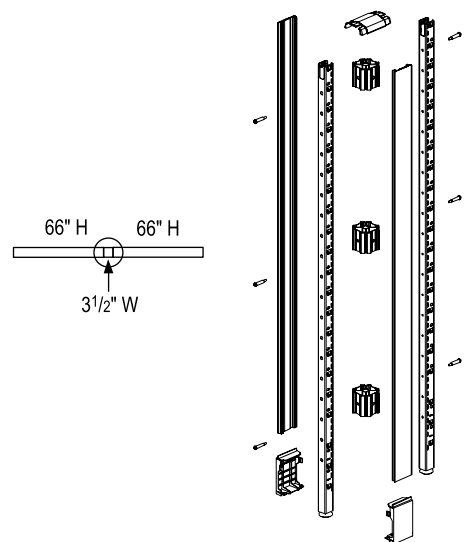

## Product Overview

### INTERSECTION CONDITIONS

#### 3-Way "T" Intersection with 3-Way Cap All Panels Same Height

Basic Model: CCTPF3W or CCTPF3W  
Includes 3-way top cap, base, three half posts, hardware, universal trim. Upholstered or upholstered.

Heights: 30", 42", 54", 66", 84"

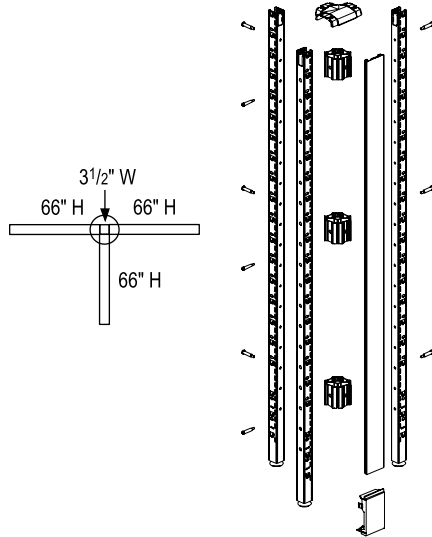

#### 3-Way "T" Intersection with Dead End Cap Two Different Heights

Basic Model: CCTPV1W or CCTPVF1W  
Includes dead end top cap, three half posts, 3-way base, hardware, universal trim. Upholstered or upholstered. Can be assembled two ways, as shown.

Heights: 30", 42", 54", 66", 84"

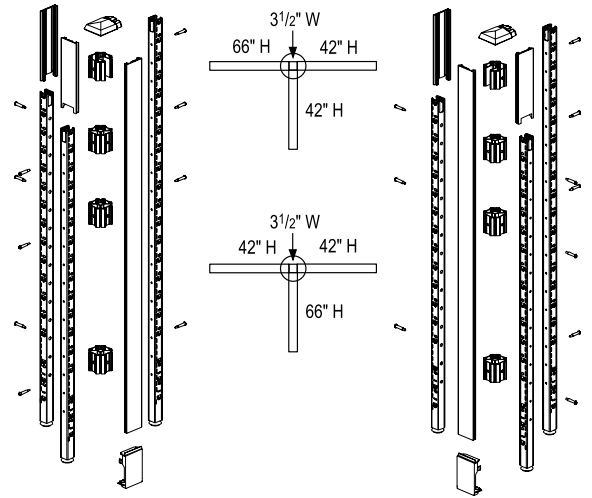

#### 3-Way "T" Intersection with 90° Top Cap Two Different Heights

Basic Model: CCTPV90 or CCTPVF90  
Includes 90° top cap, 3-way base, three half posts, hardware, universal trim. Upholstered or upholstered.

Heights: 30", 42", 54", 66", 84"

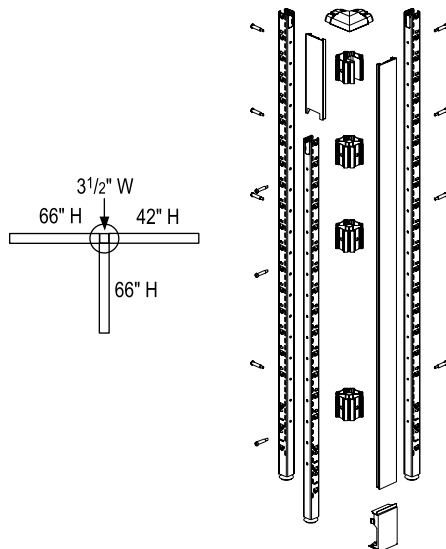

#### 3-Way "T" Intersection with 180° Top Cap Two Different Heights

Basic Model: CCTPV180 or CCTPVF180  
Includes 180° top cap, 3-way base, three half posts, hardware, universal trim. Upholstered or upholstered.

Heights: 30", 42", 54", 66", 84"

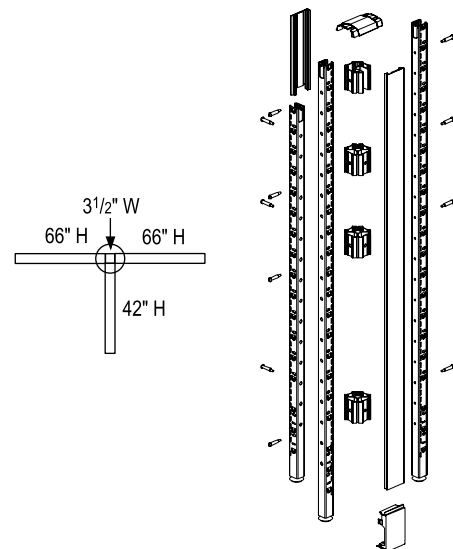

# Product Overview

## 4-Way "X" Intersection with 4-Way Top Cap All Panels Same Height

Basic Model: CCXP4W

Includes 4-way top cap & 4-way light block, four half posts, hardware. Unupholstered only.

Heights: 30", 42", 54", 66", 84"

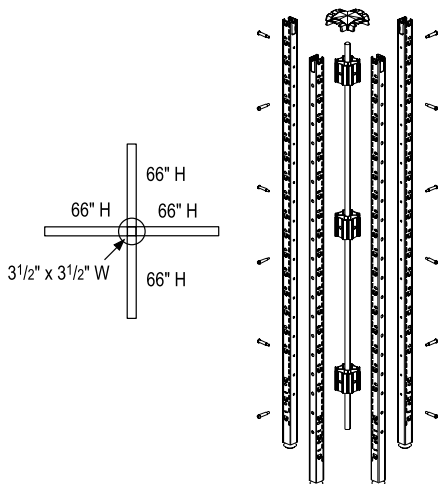

## 4-Way "X" Intersection with 180° Top Cap Two Different Heights

Basic Model: CCXPV180 or CCXPVF180

Includes 180° top cap, 4-way light block, four half posts, hardware, universal trim. Unupholstered or upholstered.

Heights: 30", 42", 54", 66", 84"

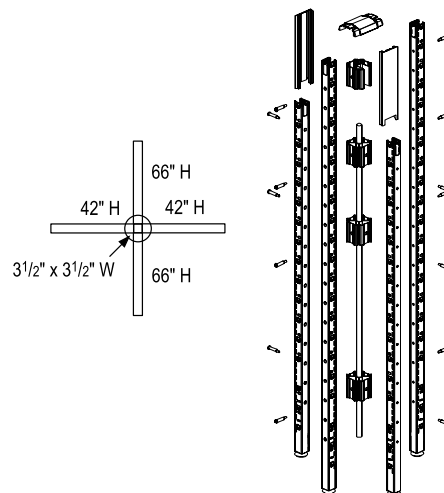

## 4-Way "X" Intersection with 3-Way Top Cap Two Different Heights

Basic Model: CCXPV3W or CCXPVF3W

Includes 4-way light block, 3-way top cap, four half posts, hardware, universal trim. Unupholstered or upholstered.

Heights: 30", 42", 54", 66", 84"

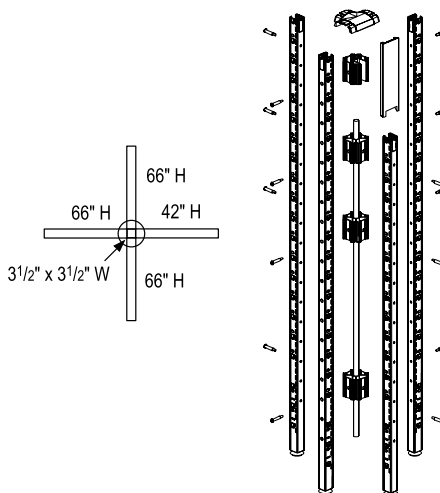

## 4-Way "X" Intersection with 90° Top Cap Two Different Heights

Basic Model: CCXPV90 or CCXPVF90

Includes 90° top cap, 4-way light block, four half posts, hardware, universal trim. Unupholstered or upholstered.

Heights: 30", 42", 54", 66", 84"

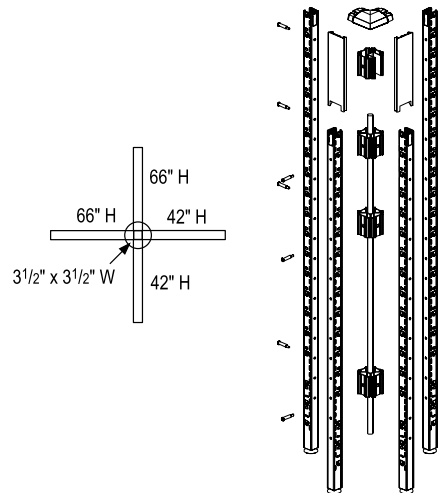

# Crescendo

## Product Overview

### WALL MOUNT COMPONENTS

#### Adjustable Wall Mount

Basic Model: CCWM

Attaches to building wall to accommodate the attachment of a half post frame component. Includes half post and assembly hardware. No wall attachment hardware included.

Heights: 30", 42", 54", 66", 84"

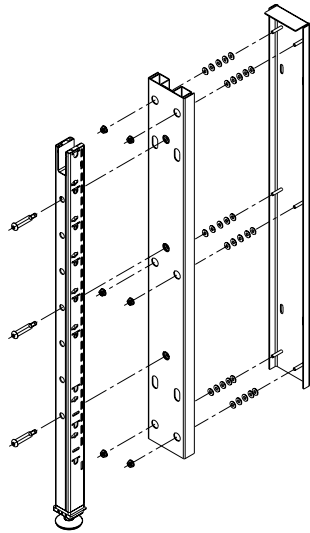

#### Wall Track

Basic Model: CCWT

Single-slotted track accommodates wall mounting of overhead components and worksurfaces. No wall attachment hardware included.

Heights: 30", 42", 54", 66", 84"



### STACKABLE INTERSECTIONS

#### 180° 2-Way In-Line Connection Both Panels Same Height

Basic Model: CCSFP

Includes two stackable half posts, two stackable height change trim, corner connector block. Unupholstered only.

Heights: 12", 18", 24"



#### End-Of-Run Condition

Basic Model: CCSEP

Includes stackable end-of-run trim, stackable full post. Unupholstered only.

Heights: 12", 18", 24"

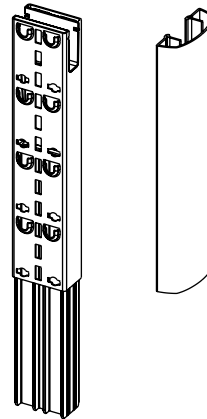



## Product Overview

**STACKABLE INTERSECTIONS****180° 2-Way In-Line Spacer  
Both Panels Same Height**

Basic Model: CCSSP or CCSSPF

Includes stackable in-line trim, two stackable half posts, corner connector block. Use top caps from existing lower panels. Unupholstered or upholstered.

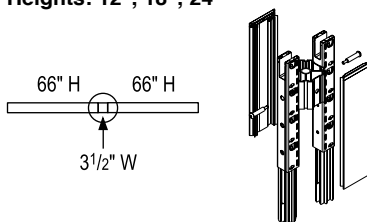
**Heights: 12", 18", 24"****3-Way "T" Intersection with 3-Way Cap  
All Panels Same Height - AAA**

Basic Model: CCSTP3W or CCSTPF3W

Includes stackable universal trim (height change), three stackable half posts, corner connector block. Use top caps from existing lower panels. Unupholstered or upholstered.

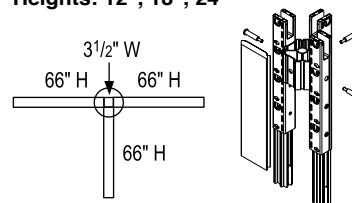
**Heights: 12", 18", 24"****90° 2-Way "L" Corner  
Both Panels Same Height**

Basic Model: CCSCP or CCSCPF

Includes two pieces of stackable universal trim (height change), two stackable half posts, corner connector block. Use top caps from existing lower panels. Unupholstered or upholstered.

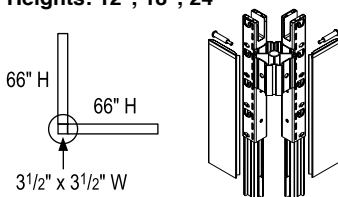
**Heights: 12", 18", 24"****4-Way "X" Intersection with 4-Way Top Cap  
All Panels Same Height**

Basic Model: CCSXP4W

Includes four stackable half posts, corner connector block, 4-way light block. Use top caps from existing lower panels. Unupholstered only.

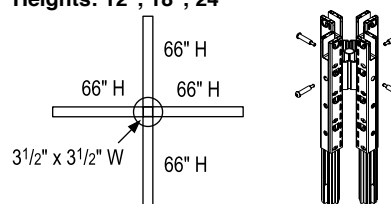
**Heights: 12", 18", 24"****Stackable Adjustable Wall Mount**

Basic Model: CCSWM

Includes mounting plate and stackable half posts. Hardware for wall attachment not included. Attaches a stackable panel to a wall at the start of a run. Adjustable up to 1" to correct wall deflection. Steel construction with painted finish.

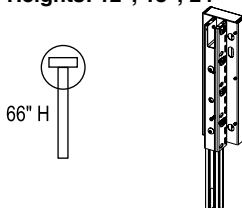
**Heights: 12", 18", 24"**

## Product Overview

### PANEL COMPONENTS Electrical Components

#### Rigid Wireway Add-on Kits

Basic Model: CCT6RW or CCT4RW

Distributes 10-wire power and allows receptacle mounting. Two super tough nylon mounting clips are attached. Wireway can be mounted inside the base raceway or any raceway tile.

**For Panel Widths: 24", 30", 36", 42", 48", 54", 60"**

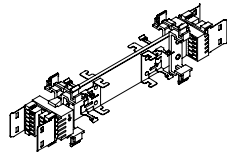

#### Power Pass Through

Basic Model: UET622EPT or UET442EPT

Provides continuation of power between two powered panels. Consists of flexible conduit with ten conductors and a connector on each end. Receptacle access is not provided.

- Provides continuation of power in a non-powered panel when powered panels are on either side.
- 12" and 18" widths use one horizontal jumper; all other sizes use two horizontal jumpers. 12" and 18" have one male and one female end.

**For Panel Widths: 12", 18", 24", 30", 36", 42", 48", 54", 60"**

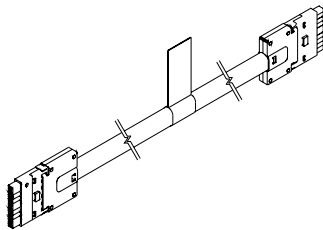

#### Receptacles & Bezels

Basic Model: CCT6RC or CCT4RC

Attaches to wireways of powered panels. Rated at 15 amps @ 120 volts. Isolated circuit receptacles are stamped with orange lettering to indicate independent, neutral, and isolated ground. Includes one filler plate which can be removed to accept standard modular furniture data plates, or reversed to allow cables to pass directly through raceway tile or door. Receptacles and bezels can be used at any height. Bezel and filler plate are nylon with trim color permeated throughout.

Isolated Receptacles:	442	622
	3I	4I
	4I	5I
		6I

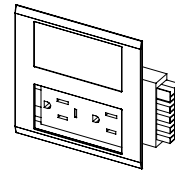

## Product Overview

### Universal Base Infeed

Basic Model: CCT6BFNH or CCT4BFNH

Fills one receptacle hole at base only. Includes bezel and filler plate. Color specific. 6' in length. Non-handed..

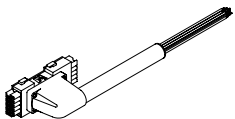

### Universal Top Feed

Basic Model: CCT6TF or CCT4TF

Includes electrical infeed, extruded aluminum power pole, and panel & ceiling trim. Two cavity design keeps power separate from data. Each cavity can manage four power infeeds or 36 - 0.20 dia cables. Color specific.

Length: 7', 10'

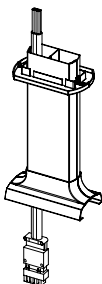

### Data Feed

Basic Model: CCDF

Includes extruded aluminum power pole and panel & ceiling trim. Two cavity design keeps power separate from data. Each cavity can manage four power infeeds or 36 - 0.20 dia cables. Color specific.

Length: 7', 10'

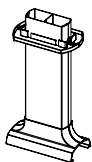

### Panel Power Connectors: Short Vertical Jumper

Basic Model: CCET6VJ20 or CCET4VJ20

Jumps power from ADA to worksurface, or worksurface to standing height.

Length: 20"

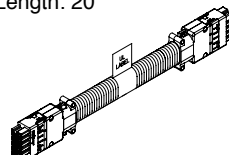

### Panel Power Connectors: Long Vertical Jumper

Basic Model: CCET6VJ56 or CCET4VJ56

Jumps power from base to ADA, worksurface, or standing height.

Length: 56"

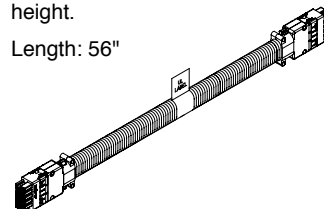

### Panel Power Connectors: Short Horizontal Jumper

Basic Model: UET6PJ17 or UET4PJ17

For in-line and 90° corner intersections.

Length: 17"

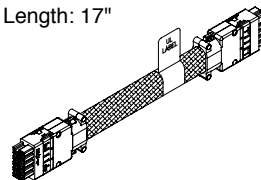

### Panel Power Connectors: Long Horizontal Jumper

Basic Model: UET6PJ20 or UET4PJ20

For straight through "T" intersections.

Length: 20"

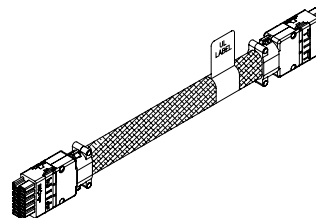

## Product Overview

### PANEL COMPONENTS Data Management Components

#### Acoustical Tile Vertical Cable Guide

Basic Model: 460097

Clips into slots in vertical post. Allows cables to be laid in between vertical posts and acoustic tile. Cannot be used with raceway tile. Each 12" of panel height will accommodate two guides for every vertical post. Order in packs of 25.



#### Acoustical Tile Horizontal Cable Support

Basic Model: 460099

Clips into bottom midpoint of horizontal rail. Aligns with vertical cable guides to keep cables supported at midpoint of panel. Cable supports gang vertically. Can also support loops of cable. Cannot be used with raceway tile, when cable trough is utilized. Order in packs of 25.

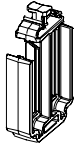

#### Top Trough Cable Guard - Full Post

Basic Model: 460047

Inserts into top of full post. Protects cables in top trough from steel edges of vertical post. Included with purchase of vertical post.



#### Top Trough Cable Guard - Half Post

Basic Model: 460048

Inserts into top of half post. Protects cables in top trough from steel edges of vertical post. Included with purchase of vertical post.



#### Acoustical Tile 90° Cable Guard

Basic Model: 460096

Clips into slots in vertical half post. Allows cables to be laid in between vertical half posts and acoustic tile at the inside of a 90° corner. Cannot be used with raceway tile. Need two guides per 12" high tile. Order in packs of 25.

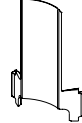

#### Horizontal Rail Cable Guard

Basic Model: 460098

Clips into end notch of horizontal rail. Protects cables when managed from top trough through notch to a different height within the panel. Order in packs of 25.



#### Top Cap 90° Cable Guard

Basic Model: 460200

Clips between vertical half posts in alignment with top trough. Protects cables when managed 90° between top troughs of adjacent panels. Order in packs of 25.



#### Raceway Tile Cable Trough

Basic Model: 460072

Manages cables behind raceway tile. Included with purchase of raceway tile.

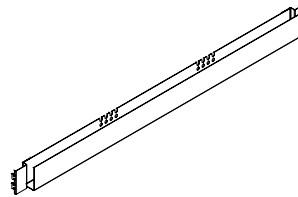

## Product Overview

### WORKSURFACES/ ACCESSORIES

Worksurfaces consist of 1 1/4" particleboard with high-pressure laminate. Edges are available in flat vinyl T-edge (BN), 2mm PVC edges (3L) and postformed/elliptical front edges with color matched vinyl edge banding (PL). Edge availability may vary with each worksurface type.

#### Rectangular Worksurfaces

Basic Model: CCWR

Includes worksurface supports. Cantilevers allow mounting to panels at 1" height increments. Worksurfaces are predrilled for suspended pedestals. 60" worksurfaces contain two steel reinforcing bars. All surfaces 66" and longer are provided with an additional left hand cantilever bracket. Optional 3" diameter grommet is available on vinyl T-edge worksurfaces. Postformed/elliptical and 3mm PVC edge worksurfaces up to 54" have one 2 1/2" x 6" grommet, 60" to 96" have two grommets.

**Width: 24", 30", 36", 42", 48", 54", 60", 66", 72", 78", 84", 90", 96"**

**Depth: 24", 30"**

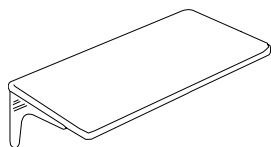

Flat Vinyl T-Edge (T)

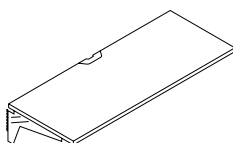

3mm PVC Edge (3L)  
Postformed/Elliptical  
Edge (M)

#### Mitered Rectangular Worksurfaces

Basic Model: CCWM

Includes worksurface supports. Cantilevers allow mounting to panels at 1" height increments. Worksurfaces are predrilled for suspended pedestals. All surfaces 66" and longer are provided with an additional left hand cantilever bracket. Worksurfaces up to 78" have one 2 1/2" x 6" grommet, 84" to 96" have two grommets.

**Width: 30", 36", 42", 48", 54", 60", 66", 72", 78", 84", 90", 96"**

**Depth: 24", 30" (30" width not available with 30" depth)**

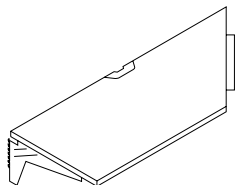

(Left)

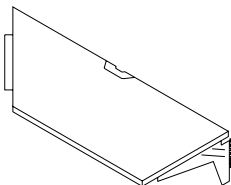

(Right)

#### "P" Shaped Peninsula Worksurfaces

Basic Model: CCWPT

Includes worksurface supports. Round end is supported by 3" diameter metal column with adjustable glide. Glide adjusts 4" in height. Cantilevers allow mounting to panels at 1" height increments. 72" worksurfaces contain two steel reinforcing bars. Worksurfaces have one 2 1/2" x 6" grommet centered on rear edge.

**24"D x 48"W x 60"L**

**24"D x 48"W x 72"L**

**30"D x 48"W x 72"L**

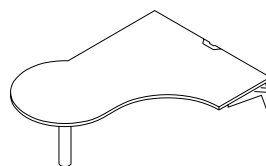

(Left shown)

#### Piano Peninsula Worksurfaces

Basic Model: CCWPP

Includes worksurface supports. Cantilevers allow mounting to panels at 1" height increments. 72" worksurfaces contain two steel reinforcing bars. Round end is supported by 3" diameter metal column with adjustable glide. Glide adjusts 4" in height. Worksurfaces have one 2 1/2" x 6" grommet centered on rear edge.

**24"D x 48"W x 60"L**

**24"D x 48"W x 72"L**

**30"D x 48"W x 72"L**

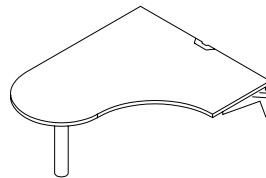

(Left shown)

## Product Overview

### WORKSURFACES/ ACCESSORIES

#### Radius Corner Peninsula Worksurface

Basic Model: CCWRC

Includes worksurface supports. Cantilevers allow mounting to panels at 1" height increments. 60" worksurfaces contain two steel reinforcing bars. All surfaces 66" and longer are provided with an additional left hand cantilever bracket. Worksurfaces have one grommet on 48" wide and two grommets on 60" and 72" wide.

**Width: 48", 60", 72"**  
**Depth: 24", 30"**

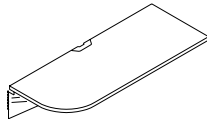

(Left shown)

#### Radius Shoe Worksurfaces

Basic Model: CCWSP

Includes worksurface supports. Cantilevers allow mounting to panels at 1" height increments. 60" worksurfaces contain two steel reinforcing bars. All surfaces 66" and longer are provided with an additional left hand cantilever bracket. Worksurfaces have one 2 1/2" x 6" grommet centered on side and rear edges.

**Width: 48"**  
**Length: 60", 66", 72", 84"**  
**Depth: 24", 30" (60" width not available with 30" depth)**

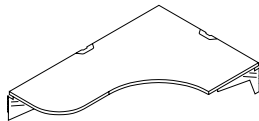

(Left shown)

#### Square Shoe Worksurfaces

Basic Model: CCWSS

Includes worksurface supports. Cantilevers allow mounting to panels at 1" height increments. 60" worksurfaces contain two steel reinforcing bars. All surfaces 66" and longer are provided with an additional left hand cantilever bracket. Worksurfaces have one 2 1/2" x 6" grommet centered on side and rear edges.

**Width: 48"**  
**Length: 60", 66", 72", 84"**  
**Depth: 24", 30" (60" width not available with 30" depth)**

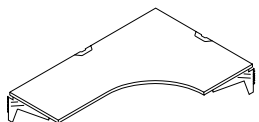

(Left shown)

#### Conference End Worksurfaces

Basic Model: CCWC

Includes worksurface supports. Conference End worksurfaces attach to the ends of two panel hung worksurfaces 24" or 30" deep at 29" to 33" in height. Includes two 3" diameter metal columns with adjustable glides. Glide adjusts 4" in height. Includes brackets to attach to adjacent worksurfaces.

**Width: 51 1/2" (to span two 24" deep worksurfaces)**  
**Depth: 25" or 31"**  
**Width: 63 1/2" (to span two 30" deep worksurfaces)**  
**Depth: 31" or 37"**

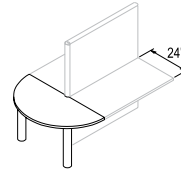

51 1/2" width

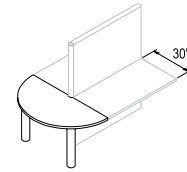

63 1/2" width

#### "D" Shaped Peninsula Worksurfaces

Basic Model: CCWP

Includes worksurface supports. D-shaped worksurfaces end mount to panels. Cantilevers allow mounting to panels at 1" height increments. The round end is supported by a 3" diameter metal column with adjustable glide. Glide adjusts 4" in height. Includes mounting hardware. 72" worksurfaces contain two steel reinforcing bars. Flat vinyl T-edge is available with a 3" diameter grommet (30" or 36" edge only).

**Width: 48", 60", 72"**  
**Depth: 30", 36" (48" width not available with 36" depth)**

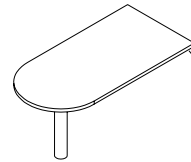

## Product Overview

### “D” Shaped Peninsula Worksurface Mounts to Another Worksurface

Basic Model: CCWSMP

Includes worksurface support. D-shaped worksurfaces side mount to worksurfaces at 29–33" height. The round end is supported by a 3" diameter metal column with adjustable glide. Glide adjusts 4" in height. 72" worksurfaces contain two steel reinforcing bars. Includes mounting hardware.

**Width: 48", 60", 72"**

**Depth: 30"**

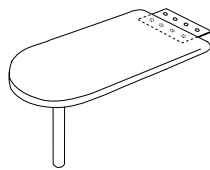

### Dual Curvilinear 90° Corner Worksurface with PositionMate

Basic Model: CCWDC

Rear surface remains stationary and front surface provides height and tilt adjustment. Variable height adjustment mechanism adjusts 5<sup>3</sup>/<sub>4</sub>" below and 7" above surface. Tilt adjustment of 9° positive and 15° negative. Spring assist mechanism will lift five pounds of equipment located on the keyboard surface. Higher capacity mechanisms are available as a special order. Worksurfaces have one 2<sup>1</sup>/<sub>2</sub>" x 6" grommet located 12" from rear corner along right rear edge.

**24" x 42" x 24"    30" x 48" x 30"**

**24" x 48" x 24"**

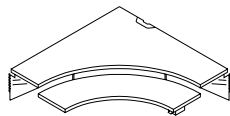

### Wing Option 90° Corner Worksurface

Basic Model: CCWW

Includes worksurface support. Front edge of worksurface is recessed. Worksurface is predrilled to accept adjustable keyboard tray. A left-hand cantilever is provided for rear corner. Worksurface is predrilled to accept adjustable keyboard arm. Cantilevers allow mounting at 1" height increments. PVC and postformed edge worksurfaces have one 2<sup>1</sup>/<sub>2</sub>" x 6" grommet located 12" from rear corner along right rear edge.

**24" x 42" x 24"    30" x 48" x 24"**

**24" x 48" x 30"    30" x 48" x 30"**

**24" x 48" x 24"**

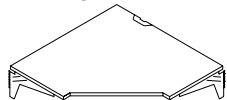

### Diagonal 90° Corner Worksurface

Basic Model: CCWD

Worksurfaces provide a straight front edge to access corner work area. A left-hand cantilever is provided for rear corner. Worksurface is predrilled to accept adjustable keyboard tray. Cantilevers allow mounting at 1" height increments. Vinyl T-edge worksurface has 3" diameter grommet. PVC and postformed edge worksurfaces have one 2<sup>1</sup>/<sub>2</sub>" x 6" grommet located 12" from rear corner along right rear edge.

**Width: 36", 42", 48"**

**Depth: 24", 30"**

**See Price List for exact sizes.**

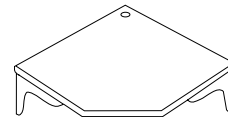

Flat Vinyl T-Edge (BN)

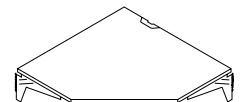

3mm PVC Edge (3L)  
Postformed/Elliptical

Edge (PL)

### Curvilinear 90° Corner Worksurface

Basic Model: CCWC

Includes worksurface supports. A left-hand cantilever is provided for rear corner. Cantilevers allow mounting at 1" height increments. Worksurface is predrilled to accept adjustable keyboard arm. Worksurfaces have one 2<sup>1</sup>/<sub>2</sub>" x 6" grommet located 12" from rear corner along right rear edge.

**Width: 36", 42", 48"**

**Depth: 24", 30"**

**See Price List for exact sizes.**



## Product Overview

### WORKSURFACES/ ACCESSORIES

#### Straight Countertops

Basic Model: CCWCT

Countertop extends 4" over the top of the panel to comply with ADA guideline 4.4.1. Brackets, which are mounted on inside of station, include steel locking clips to prevent dislodgement. Countertops accept task light. \*If countertop is installed adjacent to an in-line height change full post, a notch must be specified on the left, right, or both sides of the worksurface.

**Width: 24", 30", 36", 42", 48", 54", 60", 66", 72", 78", 84"**  
**Depth: 16"**

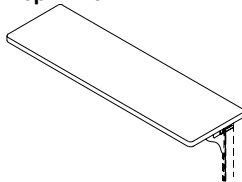

#### 90° Countertops

Basic Model: CCW90

Two-piece mitered surface with 90° right angle. To be used with 36" or 42" high panels. Brackets are mounted on inside of station; include steel locking clips to prevent dislodgement.

\*If countertop is installed adjacent to an in-line height change full post, a notch must be specified on the left, right, or both sides of the worksurface.

**Width: 24", 30", 36", Depth: 16"**

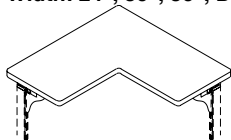

#### Straight Countertops - Wheelchair Height

Basic Model: CCWCTWC

For use with 30" high panels to place countertop no higher than 34" to comply with ADA guideline 4.32.4. Countertop extends no more than 4" into the aisle to comply with ADA guideline 4.4.1. Brackets, which are mounted on inside and outside of station, include steel locking clips to prevent dislodgement. \*If countertop is installed adjacent to an in-line height change full post, a notch must be specified on the left, right, or both sides of the worksurface.

**Width: 24", 30", 36", 42", 48", 54", 60", 66", 72", 78", 84"**  
**Depth: 16"**

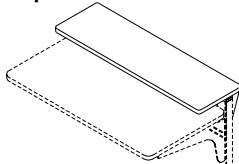

#### C-Leg Supports

Basic Model: CCCLEG

Steel leg assembly used for additional worksurface support in excessive worksurface loading situations.

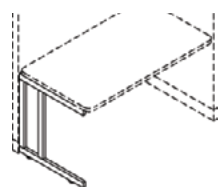

#### 90° Countertops - Wheelchair Height

Basic Model: CCWCTWC90

For use with 30" high panels to place countertop no higher than 34" to comply with ADA guideline 4.32.4. Countertop extends no more than 4" into the aisle to comply with ADA guideline 4.4.1. Two-piece mitered surface with 90° right angle (wheelchair height). Brackets, which are mounted on inside and outside of station, include steel locking clips to prevent dislodgement.

\*If countertop is installed adjacent to an in-line height change full post, a notch must be specified on the left, right, or both sides of the worksurface.

**Width: 24", 30", 36"**  
**Depth: 16"**

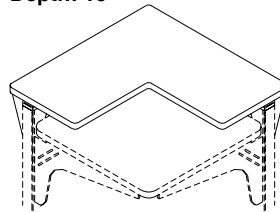

#### Worksurface Support Panel (Fabric/Laminate) or (Laminate/Laminate)

Basic Model: CCWSSP or CCWSSL

Support panel provides additional worksurface support in extensive worksurface loading applications. Mounts to panels and worksurface. Adjustable glides provide leveling capability. Specify left- or right-hand depending upon side of worksurface to which the support panel mounts.

**Height: 26", 29"**  
**Depth: 24", 30"**

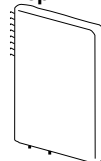

\*Note: Each notch includes one grommet cover. Cover is used when countertop is moved away from an in-line height change.

#### Tubular Support Panels Open or Perforated Design

Basic Model: PSL or PSLI

Steel support panel provides additional worksurface support while providing open air flow. The support panel mounts to panel and worksurface. Specify left or right application.

Height: 29"

Depth: 24", 30"

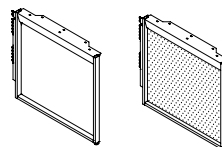



## Product Overview

### Grommets

Basic Model: CIWSG, 39.06.6020, 39.06.6021  
Bullnose edge grommet for T-edge surfaces only. Slimline grommets for 3mm edge surfaces only.



Bullnose edge

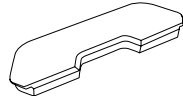

Slimline inner

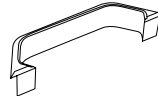

Slimline outer

### Center Drawer

Basic Model: 3CD  
One piece molded construction with ball-bearing slides. Available with key alike.

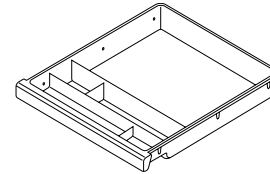

### Worksurface Support Bracket

Basic Model: CCWSB  
Provides auxiliary support to front edge of worksurface where pedestals or equipment requires additional worksurface support. Return panel must be equal to worksurface depth.

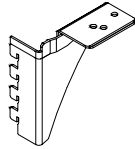

### Worksurface Vertical Filler

Basic Model: CIWSVF  
Steel bracket connects worksurface at 27" height to 29" heights. Fills gap between surfaces to prevent accidental dropping of work tools or paper.

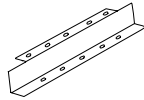

## Product Overview

### VENUS OVERHEAD STORAGE/ ACCESSORIES

#### Solid Core Upper Door

Basic Model: CCVNOS

Colored or translucent extruded PVC door. Painted cabinet and lower door. Mounting brackets included. Shelf dividers available separately. Capable of shipping assembled. Will accept hanging tackboards. (Attachment bar ordered separately).

Width: 30", 36", 42", 48", 54", 60"

Height: 17"

Depth: 19 1/4"

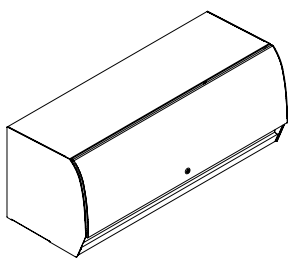

#### Laminate Upper Door

Basic Model: CCVNOL

Laminate covered upper door. Painted cabinet and lower door. Mounting brackets included. Shelf dividers available separately. Capable of shipping assembled. Will accept hanging tackboards. (Attachment bar ordered separately).

Width: 30", 36", 42", 48", 54", 60"

Height: 17"

Depth: 19 1/4"

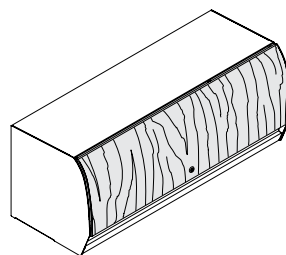

#### Fabric Upper Door

Basic Model: CCVNOF

Fabric covered upper door. Painted cabinet and lower door. Mounting brackets included. Shelf dividers available separately. Capable of shipping assembled. Will accept hanging tackboards. (Attachment bar ordered separately).

Width: 30", 36", 42", 48", 54", 60"

Height: 17"

Depth: 19 1/4"

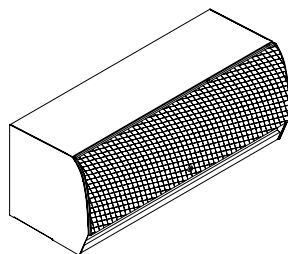

#### Tackboard Attachment Bar

Basic Model: BMB

Attachment bracket that attaches to the bottom of overhead to accept overhead tackboard. Order the same size as overhead cabinet. 18-gauge steel. Black only.

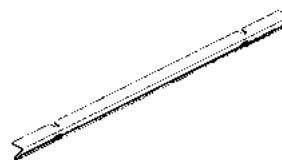

## Product Overview

### UNIVERSAL OVERHEAD STORAGE/ ACCESSORIES

Crescendo overhead cabinets and shelves are designed to allow the same overhead to be used on-module or off-module, by simply changing mounting brackets.

#### Low Shelf

Basic Model: CCLS

Steel end panels and bottom shelf. Accepts shelf dividers. End panel bracket design prevents accidental dislodging of components. Shelf depth is 13<sup>1</sup>/<sub>4</sub>". Includes 5" high back. Overhead tackboard and overhead tool rail can be suspended from underside of the shelf. Panel hung only.

**Width: 24", 30", 36", 42", 48", 54", 60"**

**Height: 9<sup>1</sup>/<sub>2</sub>"**

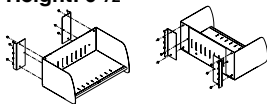

#### Regular Shelf

Basic Model: CCRS

Steel end panels and bottom shelf. Accepts shelf dividers. End panel bracket design prevents accidental dislodging of components. Shelf depth is 13<sup>1</sup>/<sub>4</sub>". Includes full back. Overhead tackboard and overhead tool rail can be suspended from underside of the shelf. Panel hung or off-module hung.

**Width: 24", 30", 36", 42", 48", 54", 60"**

**Height: 16<sup>1</sup>/<sub>2</sub>"**

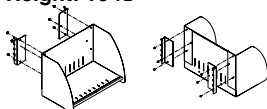

#### Steel Overhead Cabinet

Basic Model: CCRDS

Steel bottom, top shelf, and front with powder-coat finish. Double bit lock is included. Door stores recessed with PVC handle exposed. Shelf depth is 13<sup>1</sup>/<sub>4</sub>". Overhead tackboard and overhead tool rail can be suspended from underside of the cabinet. Key alike is available. Panel hung or off-module hung.

**Width: 24", 30", 36", 42", 48", 54", 60"**

**Height: 16<sup>1</sup>/<sub>2</sub>"**

**Depth: 14<sup>1</sup>/<sub>2</sub>"**

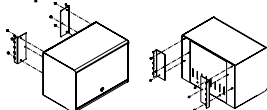

#### Fabric Overhead Cabinet

Basic Model: CCRDF

Steel end panels, bottom and top shelf with powder-coat finish. Fabric-covered front. Double bit lock is included. End panel bracket design prevents accidental dislodging of components. Door stores recessed with PVC handle exposed. Shelf depth is 13<sup>1</sup>/<sub>4</sub>". Overhead tackboard and overhead tool rail can be suspended from underside of the cabinet. Key alike is available. Panel hung or off-module hung.

**Width: 24", 30", 36", 42", 48", 54", 60"**

**Height: 16<sup>1</sup>/<sub>2</sub>"**

**Depth: 14<sup>1</sup>/<sub>2</sub>"**

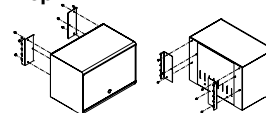

#### Laminate Overhead Cabinet

Basic Model: CCRDL

Steel end panels, bottom and top shelf with powder-coat finish. High-pressure laminate front surface. Double bit lock is included. End panel bracket design prevents accidental dislodging of components. Door stores recessed with PVC handle exposed. Shelf depth is 13<sup>1</sup>/<sub>4</sub>". Overhead tackboard and overhead tool rail can be suspended from underside of the cabinet. Key alike is available. Panel hung or off-module hung.

**Width: 24", 30", 36", 42", 48", 54", 60"**

**Height: 16<sup>1</sup>/<sub>2</sub>"**

**Depth: 14<sup>1</sup>/<sub>2</sub>"**

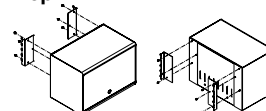

#### Shelf Dividers

Basic Model: NSD

Steel shelf dividers with powder-coat finish. Fits on all shelves and cabinets.

**Width: 7<sup>1</sup>/<sub>4</sub>"**

**Height: 11<sup>1</sup>/<sub>2</sub>"**

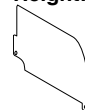

# Crescendo

## Product Overview

### LIGHTS

#### Universal Shelf/Cabinet Task Lights

Task lights mount flush with underside of shelves and overhead cabinets. UL listed. Includes 9' cord.

Electronic Ballast, Normal Power Factor

Basic Model: TLT5

Electronic ballast with rapid start cool white lamp.

For use with Cabinet Width: 24", 30", 36", 42", 48", 54", 60"

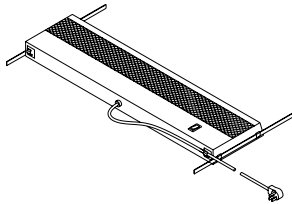

#### Venus Electronic Ballast Task Lights

Task light mounts flush to the underside of cabinet. Available in 3 widths. Light is non-handed and can be positioned left, right or center depending upon width of cabinet and light. Electronic ballast with rapid start cool white lamp.

Light Case

Product	Width
BTLT518	13"
BTLT524	24"
BTLT536	36"
BTLT548	48"

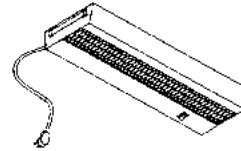

### MARKERBOARDS

#### Markerboards

Basic Model: CCMB

Includes markers and an eraser. Includes mounting brackets. White porcelain paint finished board surface. Hangs on-module.

**Width: 30", 36", 42", 48", 54", 60"**

**Height: 32"**

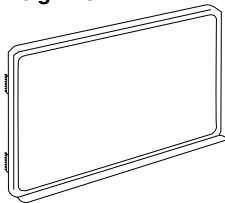

### TACKBOARDS

#### Panel Mounted Tackboard

Basic Model: CCTB

Tackboard attaches on-module to vertical post of panel. Constructed of 3/4" tackable core and covered with fabric. Includes mounting brackets. Not available with countertops. Width of tackboard must match width of panel.

**Width: 24", 30", 36", 42", 48", 54", 60"**

**Height: 12", 16", 30", 48" (60" width not available with 48" height)**

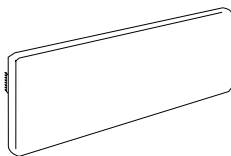

#### Overhead Tackboard

Basic Model: CCTBO

Tackboard is suspended from underside of overhead cabinet or shelf. Constructed of 3/4" tackable core and covered with fabric. Includes mounting brackets.

**Width: 24", 30", 42"**

**Height: 12"**

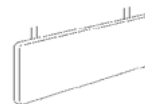

## Product Overview

### PAPER MANAGEMENT/ ACCESSORIES

#### Tool Rail

Basic Model: CCPMTR

Tool rail attaches on-module to vertical posts of panel. Extruded aluminum with four slots for paper management and accessories. Includes mounting brackets.

**Width: 18", 24", 30", 36", 42", 48", 54", 60", 72"**  
(Width of tool rail must match width of panel.)  
**Height: 4 1/2"**

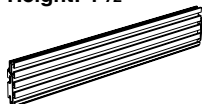

#### Hanging Folder Holder

Basic Model: CCPFH

Suspends from tool rails to support hanging file folders. Plastic construction. One pair in each set.

**1"W x 2"H x 8 1/2"D**

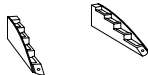

#### Plastic Paper Tray

Basic Model: CCPLL

Suspends from tool rail or freestanding on worksurfaces or shelves. Plastic construction.

**9 1/2"W x 2"H x 14"D**

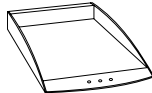

#### Plastic Vertical Storage Unit

Basic Model: CCPVS

Suspends from tool rail or freestanding on worksurfaces or shelves. Injection molded plastic construction.

**5"W x 9"H x 10 1/2"D**

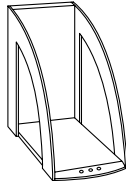

#### Telephone Caddy

Basic Model: CCPTC

The telephone caddy is adjustable to accommodate phones up to 10 3/4" deep. Caddys include three hooks for suspending from tool rails.

**8 1/2"W x 2"H x 9 1/2"D**



#### Accessory Tray

Basic Model: CCPAT

The accessory tray includes three hooks for mounting to tool rails. Trays have compartments to hold miscellaneous items. Trays can be used freestanding on worksurfaces and shelves.

**9 1/2"W x 2"H x 10"D**

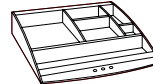

#### Pencil Cup

Basic Model: CCPPC

The pencil cup for storage of pens and pencils. Includes one hook to mount on tool rail.

**4"W x 4"H x 3 1/2"D**



## Planning Guidelines

### PANEL SUPPORT AND LOADING

The following figures show the maximum and minimum requirements for safe loading and supporting of panels. Review them carefully to insure panel stability:

#### Unloaded Panel Runs Starting With Wall Mounts

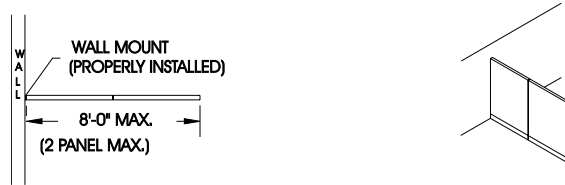

Return panel must be equal to, or within 18" of the height of the main panel run.

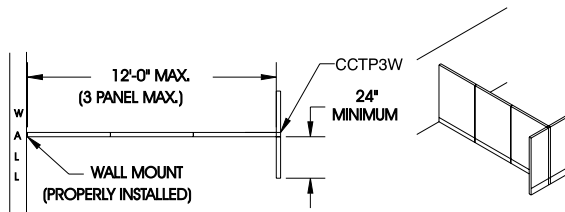

Return panels can be any height when they return in opposite directions as shown at left.

#### Unloaded Freestanding Runs With Returns At Both Ends

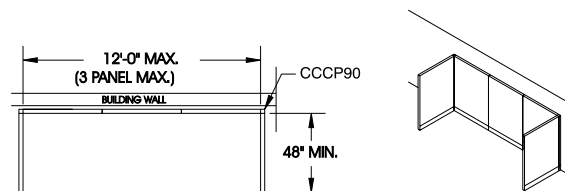

Return panel(s) must be equal to, or within 18" of the height of the main panel run, UNLESS the main panel run is tight against a building wall. If the main run is tight against the building wall, the return panels can be any height.

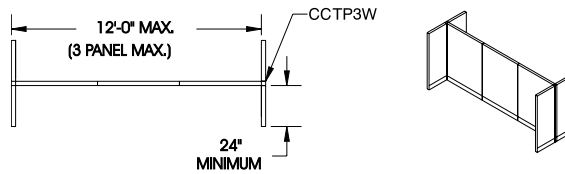

Return panels can be any height when they return in opposite directions as shown at left.

# Planning Guidelines

## Worksurface Loaded Panels Starting With Wall Mounts

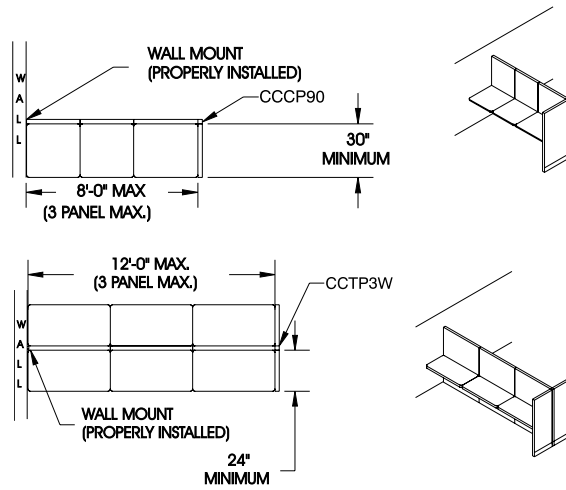

Return panel must be equal to, or within 18" of the height of the main panel run.

Return panels can be any height when they return in opposite directions as shown at left.

## Worksurface Loaded Freestanding Runs With Returns At Both Ends

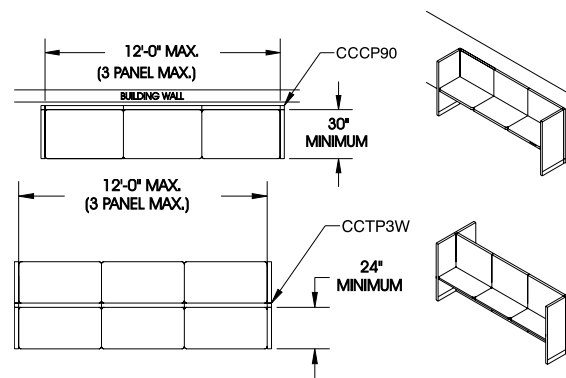

When loading freestanding panels with worksurfaces, return panels must be used on both ends. An option on one end is to use worksurface support panels (CCWSSP or CCWSSL) in some situations.

Return panel(s) must be equal to, or within 18" of the height of the main panel run, UNLESS the main panel run is tight against a building wall. If the main run is tight against the building wall, the return panels can be any height.

Return panels can be any height when they return in opposite directions as shown at left.

# Planning Guidelines

**PANEL SUPPORT AND LOADING**

**Storage Unit Loaded Panel Runs Starting With Wall Mounts – One or Two Units Per Panel**

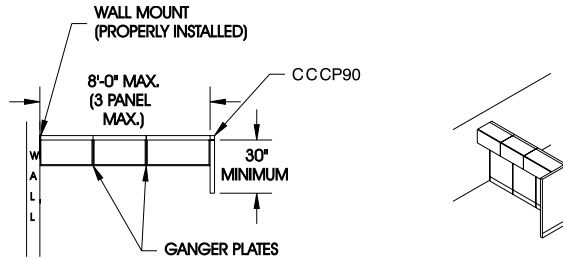

Return panel must be equal to, or within 18" of, the height of the main panel run, and must be on the same side as the storage units. All adjacent overhead units must have overhead ganger plates attached between them.

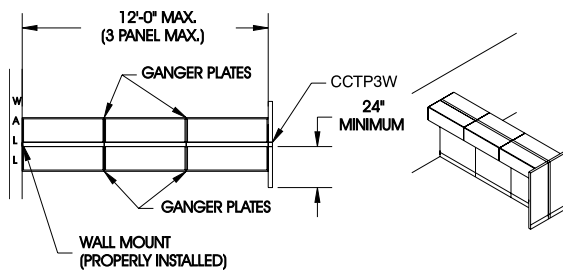

Return panels must be equal to, or within 18" of, the height of the main panel run when they return in opposite directions as shown at left. All adjacent overhead units must have overhead ganger plates attached between them.

**Storage Unit Loaded Freestanding Runs With Returns At Both Ends – One or Two Units Per Panel**

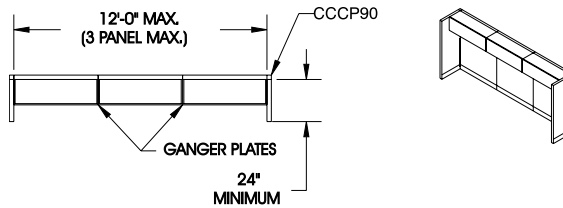

Return panels must be equal to, or within 18" of, the height of the main panel run. Return panels must be specified at each end of the storage unit panel run, and must be on the same side as the storage units. All adjacent overhead units must have overhead ganger plates attached between them.

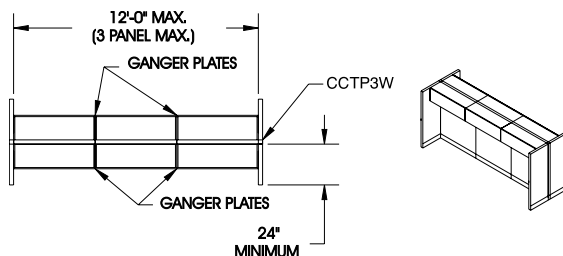

Return panels must be equal to, or within 18" of, the height of the main panel run. Return panels must be specified at each end of the storage unit panel run. All adjacent overhead units must have overhead ganger plates attached between them.



# Planning Guidelines

## STORAGE UNITS

### Storage Unit Loaded Panel Runs With Three Or More Storage Units Per Panel

The following number of storage units will fit on the specified height panels.

Panel Height	Low Shelves Stacked Tight 10" Req'd	Low Shelves with Folders 14" Req'd	Regular Shelves or Receding Door Cabinets 17" Req'd
48"	4	3	2
54"	4	3	2
60"	5	4	3
66"	6	4	3
72"	6	4	3
78"	7	5	4
84"	7	5	4

When three or more storage units are mounted on one side of a panel, storage units must be panel wrapped with return panels at least 30" wide and equal to, or within 12" of, the height of the panel the storage units are mounted on.

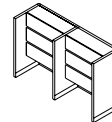
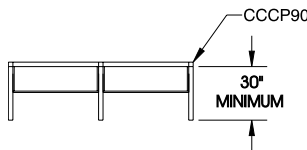

Return panel(s) must be equal to, or within 12" of, the height of the main panel run.

An overhead with receding door located in a corner must be adjacent to a perpendicular panel of no less than 30" wide if the open door is to clear a second overhead positioned at 90° from the first (see below).

### Panel Wrapping Lateral Files

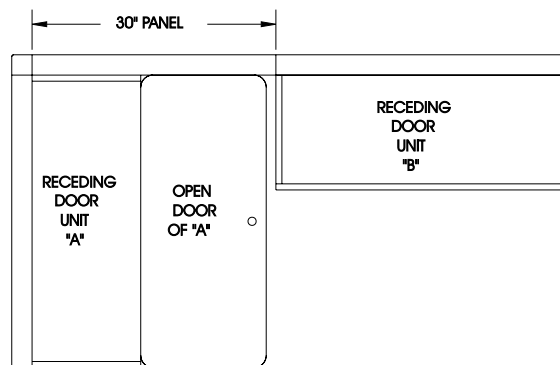

When panel wrapping one lateral file, the panel behind the file can be the same size as the width of the file (30", 36", or 42"). The return panels on each side of the lateral file will stay in place when carpet grippers are used.

When panel wrapping more than one lateral file that have been placed side by side, use panels behind the files that are at least 6" wider than the file.

EXAMPLE: Two 30" lateral files = 60" wide  
Use a panel combination that equals at least 66" behind the files.

The reason for the 6" difference is that no matter how tight the files are ganged together, the small air space between the files adds up, and the return panels on each side will not stay in position.

## Planning Guidelines

### PANEL MOUNTING GUIDELINES

#### Vertical Stacking of On-Module Components

The following charts provide a quick reference source for the hang-on capacity of Crescendo panels.

The first table shows the actual number of inches available on each size panel to hang components. The hang-on capacity of each panel size is less than the height of the panel, because of the raceway at the bottom of the panel.

Panel Height	Actual Hang On Space
30"	24"
36"	30"
42"	36"
48"	42"
54"	48"
60"	54"
66"	60"
72"	66"
78"	72"
84"	78"

The following table shows the actual number of inches in height each product takes up on a panel. In addition to the actual heights, any special clearance inches are also listed.

Be sure to check the specifying section on loaded panels to be sure the panels are adequately supported.

Product	Vertical Size	Special Notes
Worksurface with cantilever bracket	13"	Worksurfaces are usually mounted at about 30" high; therefore, the lower 25" of available space is used.
Countertop with standard ADA bracket	6" of bracket plus 2" of worksurface	The 8" total includes 6" of hang on space used by the bracket plus 2" of worksurface and top cap that is above the bracket.
Low Shelves	10"	If you are storing anything taller than 7", use the height of the object plus 3".
Regular Shelves	16"	If you are storing anything taller than 13", use the height of the object plus 2".
Storage Overhead Unit	17"	Two on-module tackboards cannot be hung adjacent to each other at the
Tackboards	12", 16", 30", & 48"	inside of a 90° corner.
Markerboards	32"	

## Planning Guidelines

### WEIGHT CAPACITIES

#### Notes About Hang-On Components

Crescendo hang-on components (excluding markerboards, tackboards and tool rails) include a specially designed hanger bracket to prevent accidental dislodgement from the panel or wall track.

All Crescendo components meet or exceed the BIFMA (Business and Institutional Furniture Manufacturers Association) standards for hang-on components.

BIFMA has two load tests for hang-on components:

1. Functional Load - at this load the test furniture must still be useable with no deformation or breakage.
2. Proof Load - at this load the test furniture must still be safely usable, but deformation is allowed.

The following are the BIFMA test loads for two categories of hang-on components, worksurfaces and overhead storage units.

#### Worksurfaces:

Functional Load: 4.5 lbs/linear inch for 60 minutes

Proof Load: 7.0 lbs/linear inch for 15 minutes  
(300 lb minimum)

Worksurface Length	Functional Load	Proof Load
24"	108 lbs	300 lbs
30"	135 lbs	300 lbs
36"	162 lbs	300 lbs
42"	189 lbs	300 lbs
48"	216 lbs	336 lbs
54"	243 lbs	378 lbs
60"	270 lbs	420 lbs
72"	324 lbs	504 lbs
84"	378 lbs	588 lbs
90"	405 lbs	630 lbs
96"	432 lbs	672 lbs

#### Overhead Storage Units:

Functional Load: 3.0 lbs/linear inch for 60 minutes

Proof Load: 5.0 lbs/linear inch for 15 minutes

Overall Length	Functional Load	Proof Load
24"	72 lbs	120 lbs
30"	90 lbs	150 lbs
36"	108 lbs	180 lbs
42"	126 lbs	210 lbs
48"	144 lbs	240 lbs
54"	162 lbs	270 lbs
60"	180 lbs	300 lbs

Note: The lifting force required to open an overhead door (based upon a 48" unit) is 6.0 lbs.

## Planning Guidelines

### WALL MOUNTING

#### Adjustable Wall Mount Kits

The adjustable wall mount can make up for a wall being up to 1.25" out of plumb.

An adjustable wall mount adds 1.25" - 2.50" to the length of a panel run (see below).

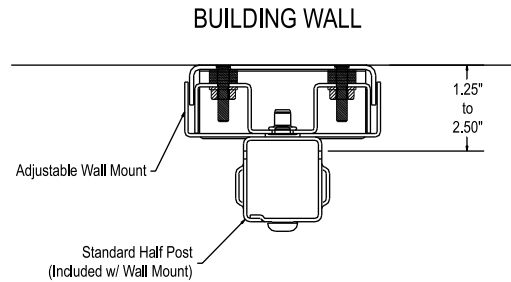

If two wall mounts are being used on one panel run between two building walls (see below) and the panel run length comes up less than 6" short of the total distance, the following solution has been used.

The customer shims out the wall using layers of wood and the wall mount is then attached to the shim.

Note: Shim to be provided by installer.

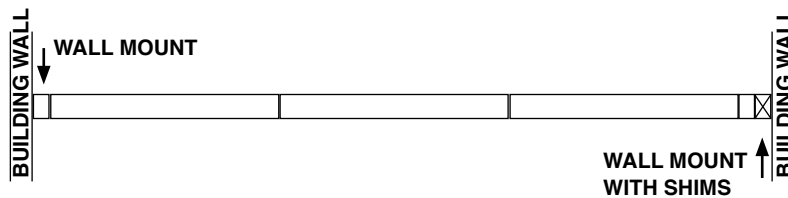

## Planning Guidelines

### Wall Track

Wall track allows you to mount Crescendo hang-on components directly onto a wall without the use of Crescendo panels. The wall track comes in 30", 66", and 84" lengths but can be cut to shorter lengths for hanging worksurfaces only.

Wall track should always run all the way to the floor.

Wall track **MUST** be anchored into one of the following wall types:

- a. A concrete wall using a good quality concrete anchor installed to the manufacturer's recommendation.
- b. A dry wall surface that is over a minimum  $\frac{3}{8}$ " thick plywood. Secure the wall track using a good quality hollow wall anchor (toggle bolt) installed according to the manufacturer's recommendations.
- c. A dry wall surface where all of the wall track is mounted directly into the wood or steel wall studs. Secure the wall track to the wood stud using at least a #10 x  $2\frac{1}{2}$ " wood screw, or a good quality hollow wall anchor (toggle bolt) installed in the steel stud to the manufacturer's recommendations.

Note: All holes in the wall track should be used regardless of the length.

If possible, it is recommended to also specify worksurface supporting pedestals to provide added support to wall track mounted worksurface.

Wall track is single slotted (see description section) however, one piece of wall track can actually support two adjacent hang-on components (see below).

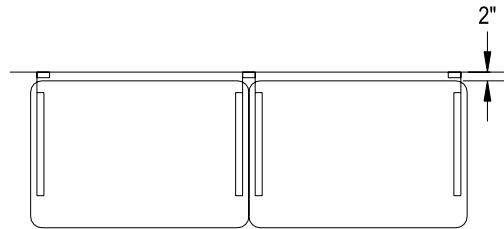

Worksurfaces that are hung on wall track will have a space about 2" wide between the back of the worksurface and the wall.

## Planning Guidelines

### STACKING SECTION GUIDELINES

The following specifications apply to stackable sections. Stackable sections must always remain below the ceiling. To stack on top of a fully assembled panel at least 7" of clearance should be left between the top of the panel and the ceiling. If less clearance is available, the panel frame must be disassembled before adding or removing stacking sections.

#### Load Bearing Applications

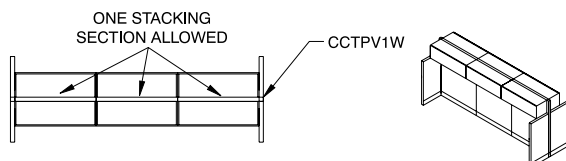

Stacking sections are designed to be load bearing, however, only one stacking section is allowed at or below the height of the load bearing components. Unloaded return panels can utilize any number of stacking sections.

#### Non-Load Bearing Applications

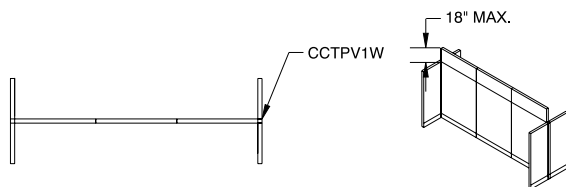

When panels will not be bearing loads, any number of stacking sections may be used, however, you still must keep return panels within 18" in height from the main run for stability reasons. Panels can be stacked to a maximum height of 12' and must be below the ceiling.

# Planning Guidelines

## DOOR GUIDELINES

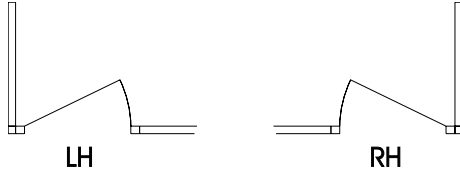

Panel doors are available in a 42" width only. The actual door opening is 36". The 42" panel allows for handicap accessibility.

Panel doors come in right-hand (R), and left-hand (L) versions (see at left).

An easy way to remember the difference is: which hand would you have on the door knob as you walk into the room and open the door away from you.

A 42" door occupies the same amount of room as a

standard 42" panel.

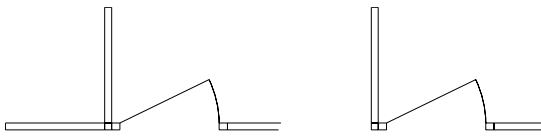

Always try to place the hinge side of the panel door so it is part of a "T" or "Corner" configuration (see at left).

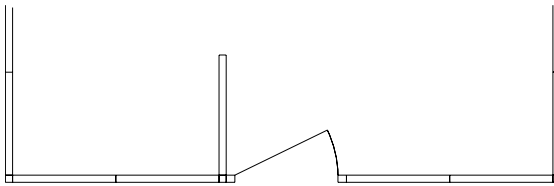

The panel that the door opens against must be an 84" tall panel and must be either at least as wide as the panel door width, or be part of a panel run that is larger than the panel door width. The panel that adjoins the door on the latch side should be 84" tall.

If a panel door is requested in the middle of a straight panel run, an 84" tall panel equal to or greater than the width of the panel door, should be placed on the hinge side so the door opens against it (see at left).

# Crescendo

## Planning Guidelines

### DOOR GUIDELINES

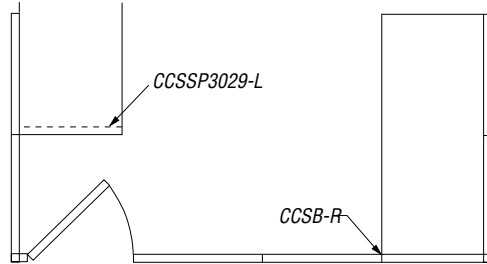

Use worksurface support brackets or worksurface support panels whenever a worksurface adjoins or hangs on a run of panels containing a door.

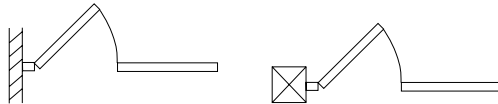

A panel door may be used with a wallmount to connect the panel door to a column or wall. Mounting must be either parallel to the column or perpendicular to the wall.

A panel door cannot be used with an off-module post unless a panel is used between the door and the panel being mounted to.

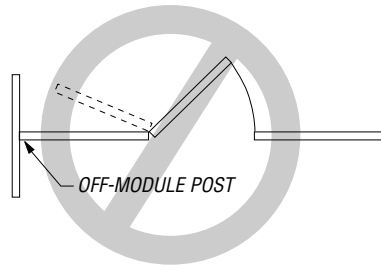

Never reduce panel heights at a 90° intersection containing a door panel (example: a corner office with windows). Always round a corner with an 84" high panel equal or greater in width than the door. At that point a lower panel could be used.

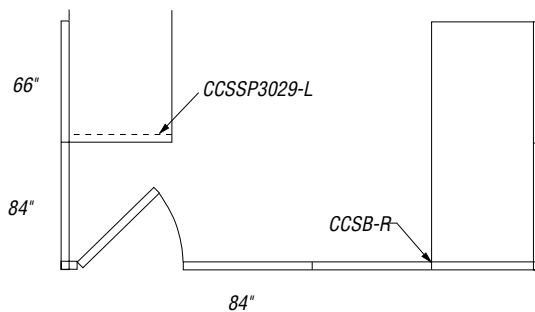



## Planning Guidelines

### RECONFIGURING PANELS

The following are common reconfigurations to illustrate how easy modifying your existing layout can be. Every original layout and initial installation of Crescendo is different, so the steps listed below may vary in specific environments.

Hint: Worksurface cantilever brackets have elongated slots, rather than holes, for attachment screws. These slots allow for worksurfaces to be pulled away from the panel one inch so tiles can be removed from the panel without removing the worksurface entirely.

#### Adding a Stacking Section

Add a stacking section to the top of an existing monolithic panel in which the top horizontal rail contains cables.

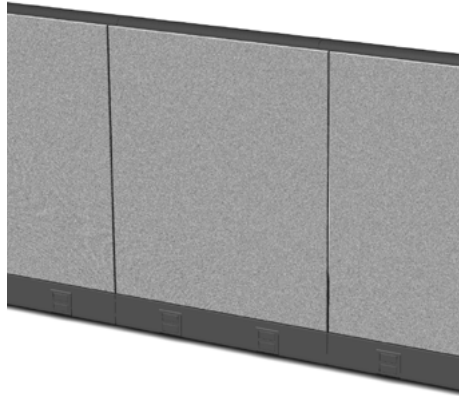

1. Remove top trim from the panel that will receive stacking sections and the adjacent panels.

2. Remove tiles from both sides of these panels. To remove tiles from panels which support rectangular worksurfaces without disturbing the equipment on the worksurface, loosen the screws on cantilever bracket just enough to slide the worksurface forward one inch.

3. Remove cables from the top horizontal rail of all panels affected and let hang.

4. Remove the top horizontal rail from the panels immediately adjacent to the run of stacking sections. Note: On monolithic panels it is necessary to always have a minimum of two horizontal rails. Before removing the top horizontal rail of any monolithic panel, first install a horizontal rail at another height.



## Planning Guidelines

### RECONFIGURING PANELS

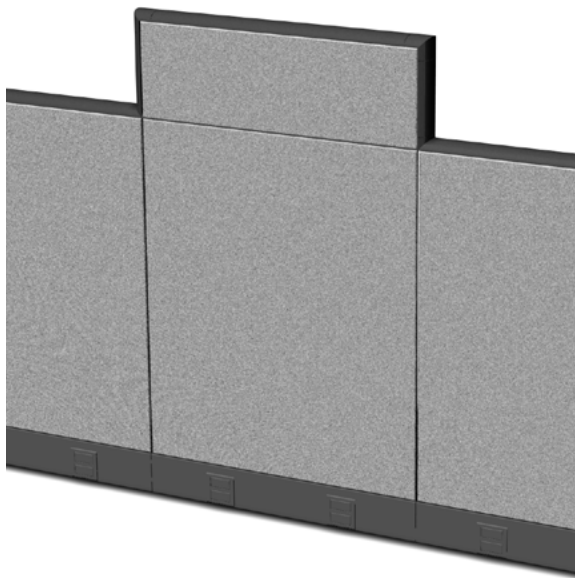
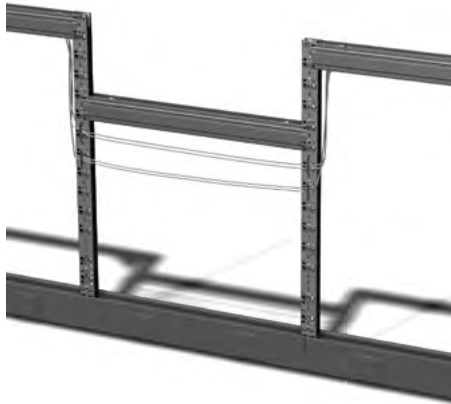

5. Install vertical cable guides on vertical posts of the stacking section. Note: Vertical cable guides occupy the same slots in the vertical posts as the brackets for all hanging components. In order to insure that overheads and tackboards can be hung from the vertical posts, it is best to locate the vertical cable guides 49 inches from the floor. Refer to Guide Diagram on page 73.

6. Reroute cables down through the notch at the end of the removed horizontal rails of the adjacent panels then reattach these rails. Then, reroute cables behind vertical cable guides below the stacking sections.

7. Remove the cable guards from the top of each of the vertical posts that will be receiving a stacking vertical post. Install stacking vertical posts, horizontal rails, and tiles.

8. Reuse the top trim from previous panels and install new "change of height end-of-run caps."

9. Replace monolithic tiles. Slide worksurfaces back to original position and tighten screws.

## Planning Guidelines

### RECONFIGURING PANELS

#### Reducing Height of a Monolithic Panel

Reduce height of monolithic panel in the middle of a run in which the top horizontal rail contains cables.

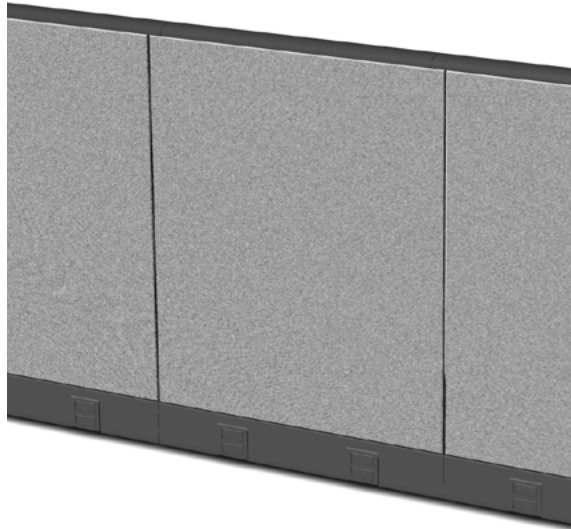

1. Remove top trim from all panels that will be reduced in height and adjacent panels.
2. Remove tiles from both sides of the reduced height panels and from the adjacent panels. To remove tiles from panels, which support rectangular worksurfaces without disturbing the equipment on the worksurface, loosen the screws on cantilever bracket just enough to slide the worksurface forward one inch.
3. Remove cables from the top horizontal rail of all panels affected and let hang.
4. Remove the top horizontal rail from the panels immediately adjacent to the reduced height panels. **Note:** On monolithic panels it is necessary to always have a minimum of two horizontal rails. Before removing the top horizontal rail of any monolithic panel, first install a horizontal rail at worksurface height.
5. Install vertical cable guides on vertical posts of the stacking section. **Note:** Vertical cable guides occupy the same slots in the vertical posts as the brackets for all hanging components. In order to insure that overheads and tackboards can be hung from the vertical posts, it is best to locate the vertical cable guides 49 inches from the floor. Refer to Guide Diagram on page 73.

## Planning Guidelines

### RECONFIGURING PANELS

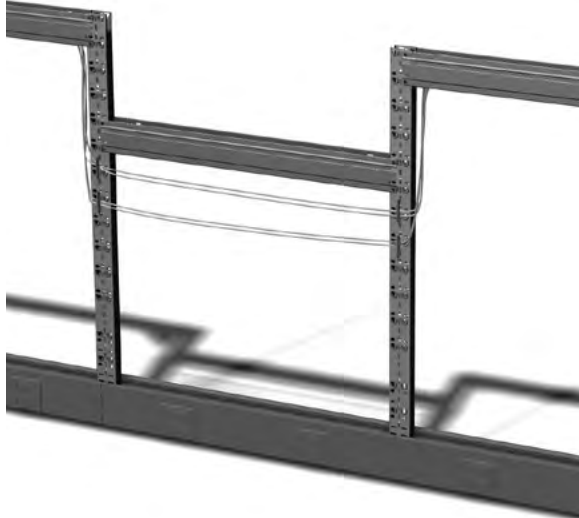

6. Reroute cables down through the notch at the end of the removed horizontal rails of the adjacent panels; then reattach these rails. Reroute cables behind vertical cable guides below the reducing sections.

7. Relocate top horizontal rail to new lower position on reduced height panels.

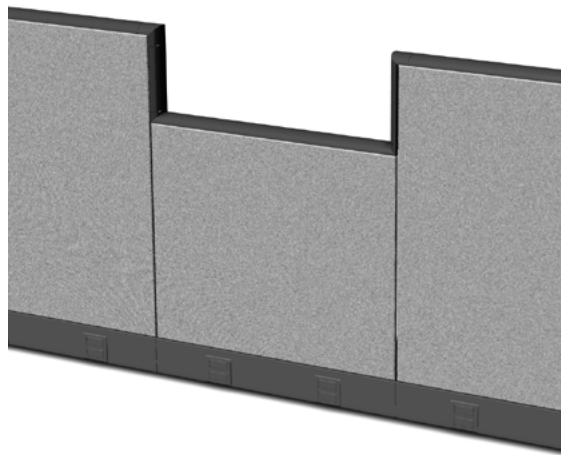

8. The new reduced height panel can reuse the top trim from the taller version by cutting the trim to the proper length. Install in-line height change trim on both posts of the reduced height, then trim the top trim to fit. Note: The new in-line height change trim can be ordered as a kit of parts or as separate pieces.

9. Replace monolithic tiles. Slide worksurfaces back to original position and tighten screws.

## Planning Guidelines

### RECONFIGURING PANELS

#### Adding a Walkthrough in Middle of Run

Add a walkthrough in the middle of a run of monolithic panels in which the top horizontal rail contains cables. Walkthrough can be used with or without door.

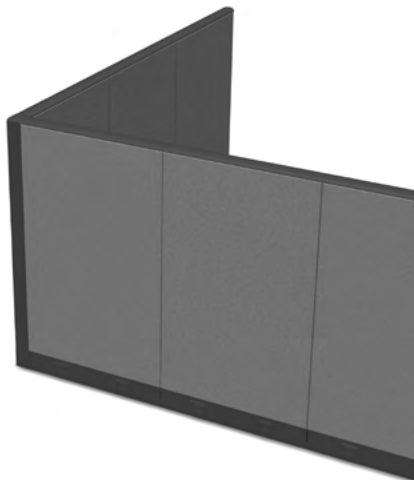

1. Remove top trim from panel that will be removed and next two panels on both sides of walkthrough.

2. Remove tiles from both sides of all of these panels. To remove tiles from adjacent panels, which support rectangular worksurfaces without disturbing the equipment on the worksurface, loosen the screws on cantilever bracket just enough to slide the worksurface forward one inch.

3. Remove cables from the top horizontal rail of all panels affected and let hang.

4. Remove the top horizontal rail from the panels which are immediately adjacent to the run of increased height panels (Panels directly adjacent to walkthrough must be stacked to match walkthrough height). Note: On monolithic panels it is necessary to always have a minimum of two horizontal rails. Before removing the top horizontal rail of any monolithic panel, first install a horizontal rail at worksurface height.

5. Install vertical cable guides on vertical posts at ends of the stacking section. Note: Vertical cable guides occupy the same slots in the vertical posts as the brackets for all hanging components. In order to insure that overheads and tackboards can be hung from the vertical posts, it is best to locate the vertical cable guides 49 inches from the floor. Refer to Guide Diagram on page 73.

# Crescendo

## Planning Guidelines

### RECONFIGURING PANELS

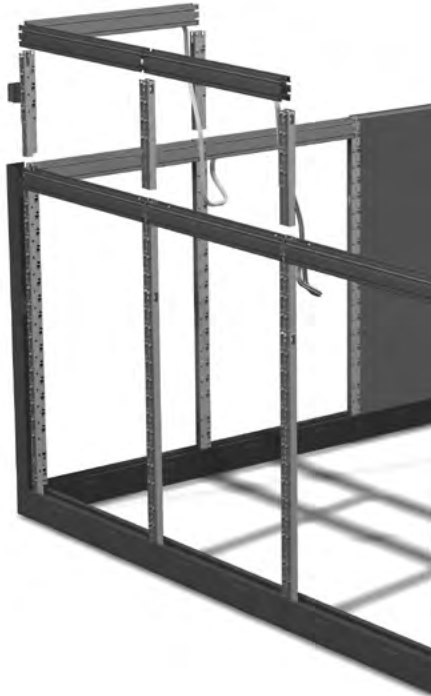

6. Add stacking vertical posts to walkthrough and adjacent panels to extend walkthrough panel height to 84".

7. Remove top horizontal rail of walkthrough and adjacent panels and relocate at top of stacking sections to bridge the space over removed panel. Note: On monolithic panels it is necessary to always have a minimum of two horizontal rails. Before removing the top horizontal rail of any monolithic panel, first install a horizontal rail at worksurface height.

8. Reroute cables down through the notch at the end of the removed horizontal rails of adjacent panels; then reattach these rails. Reroute cables behind vertical cable guides, up through notches in adjacent stacking panels, and through the horizontal rail over walkthrough.

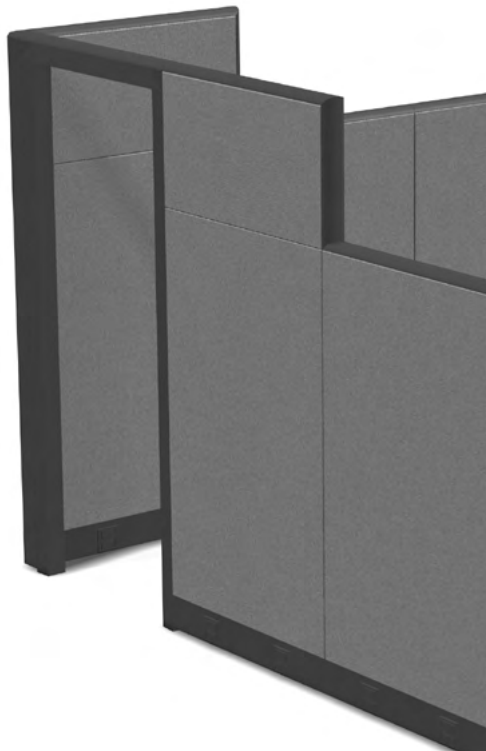

9. Replace monolithic tiles. Reuse the top trim from the previous panel for the top of the horizontal rail and add change in height trim to the stacking sections. Note: If the opening will not be used with a door, then specify door passthrough trim in 42" width.

## Planning Guidelines

### RECONFIGURING PANELS

#### Adding Power to Monolithic Panel at ADA, Belt, or Stand-up height

Add ADA, Belt, or Stand-up height rigid wireways to a monolithic panel.

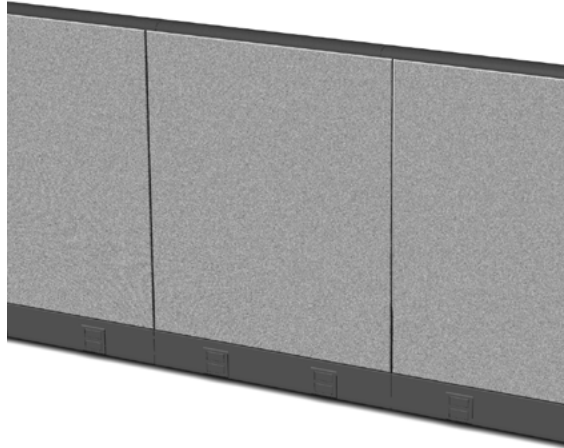

1. Remove tiles from the side(s) of the panel which provides receptacles. To remove tiles from panels, which support rectangular worksurfaces without disturbing the equipment on the worksurface, loosen the screws on cantilever bracket just enough to slide the worksurface forward one inch.

2. Install a horizontal rail and rigid wireway with receptacles at the desired height(s).

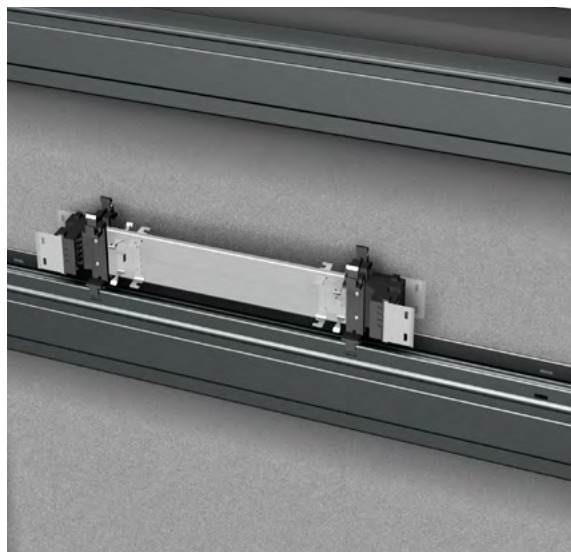

## Planning Guidelines

### RECONFIGURING PANELS

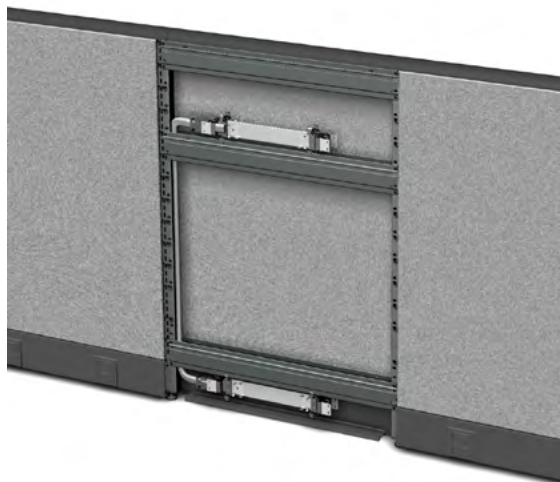

3. Use either vertical or horizontal jumpers to connect rigid wireway(s) to power of same or adjacent panel.

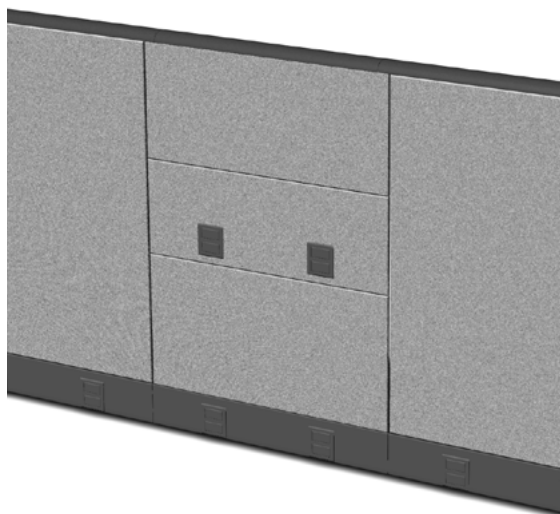
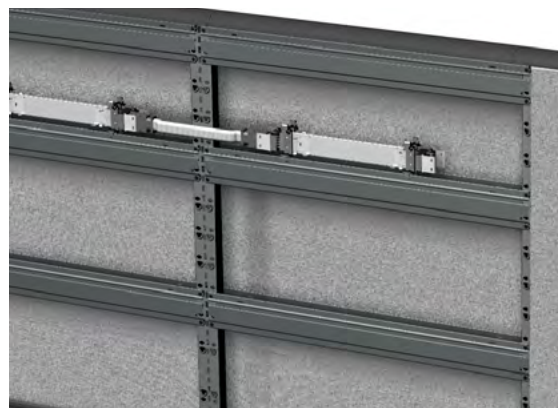

4. Add additional horizontal rails, raceway tiles, and acoustic tiles to remainder of panel.

(Note: Cannot use horizontal jumpers behind acoustical tiles).



## Planning Guidelines

### RECONFIGURING PANELS

#### Storing Excess Cables

Store excess cable within a monolithic panel in which the top horizontal rail contains cables.

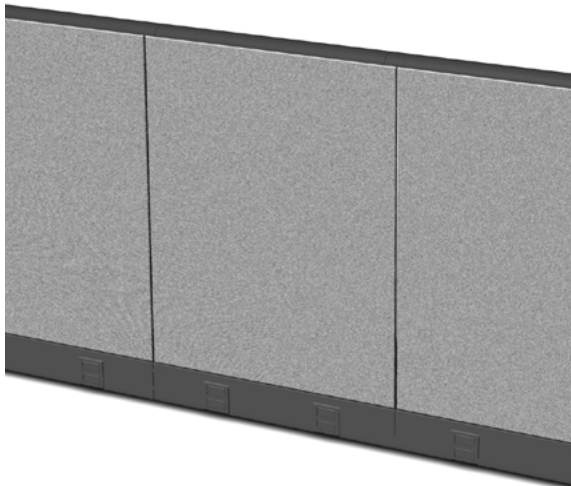

1. Remove top trim from all panels that will store excess cable.

2. Remove tiles from both sides of the panels. To remove tiles from panels which support rectangular worksurfaces, without disturbing the equipment on the worksurface, loosen the screws on cantilever bracket just enough to slide the worksurface forward one inch.

3. Remove cable from top horizontal rail and let hang.

4. Remove the top horizontal rail from panel which will store cable. Note: On monolithic panels it is necessary to always have a minimum of two horizontal rails. Before removing the top horizontal rail of any monolithic panel, first install a horizontal rail at worksurface height.

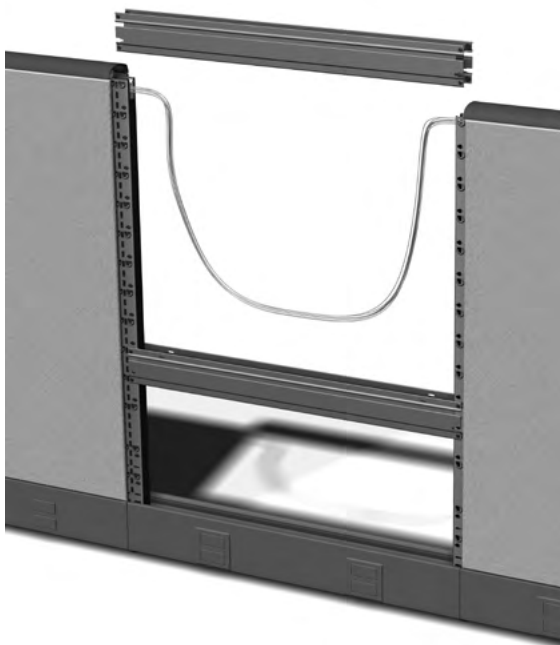

## Planning Guidelines

### RECONFIGURING PANELS

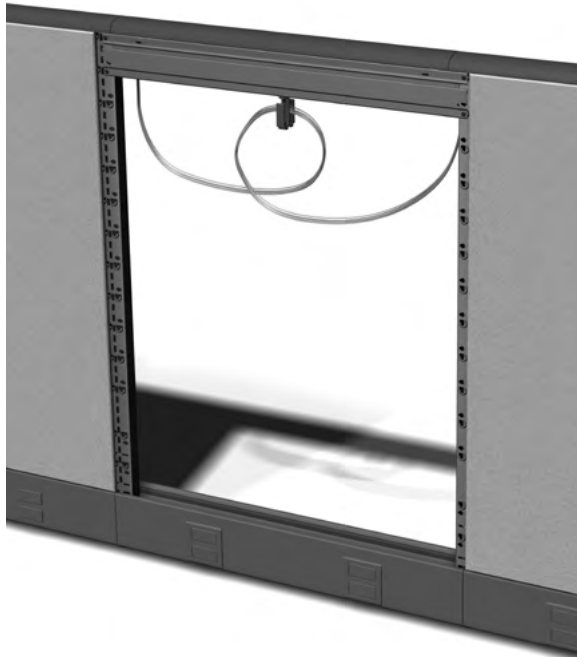

5. Reroute cables down through the notch at the end of the removed horizontal rail. Then reattach the rail. Relocate all excess cable into interior of panel and coil cable into loops.
6. Install acoustical tile horizontal cable support and hang loops of cable from the support.  
Note: Additional horizontal rails can be added to the panel to help support additional loops of cable.

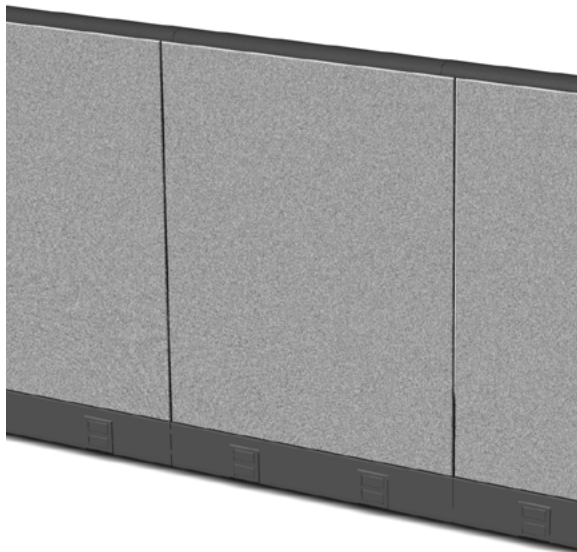

7. Replace tiles and trim.

## Planning Guidelines

### RECONFIGURING PANELS

#### Utilizing Crescendo as a Spine Wall

1. Specify either half-segmented or fully-segmented panels.
  2. Specify "off-module" overheads.
  3. Specify overhead suspended tackboards and toolrails.
  4. Specify "off-module" panel posts instead of 90 degree corners, or 3-way or 4-way intersection conditions, to connect wing walls to spine walls.
  5. Specify power and data receptacles in the spine wall only and not the wing walls.
- (Note: Power/Data cannot be run between an off module panel connection and a spine wall).
6. Specify "off-module" worksurfaces such as stand alone tables.

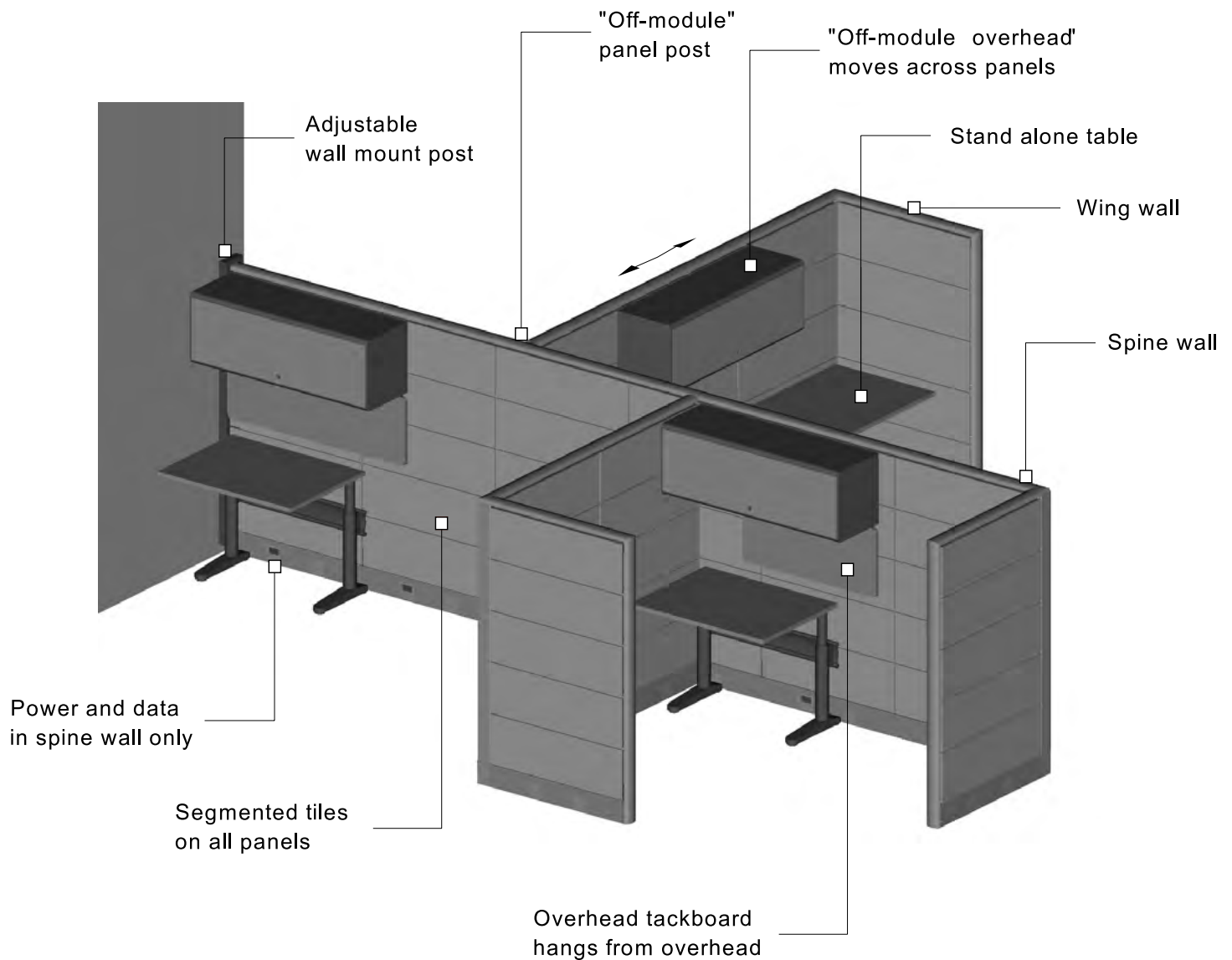

# Crescendo

## Planning Guidelines

### ELECTRICAL POWER

Each Crescendo panel can provide power in a number of ways. Depending on a panel's use, power can be supplied at varying heights, at multiple locations, or not at all. Power is supplied to Crescendo panels using one of two types of power infeeds – base or ceiling. Rigid wireways provide power access through duplex receptacles at varying heights. Vertical and horizontal jumpers allow the routing of power to different heights and between panels.

#### Power Options

Power can be run at four standard heights on a 54" high and taller Crescendo panel: base, ADA, worksurface, and standing. Each level of power can provide four, 20 amp circuits. Therefore, four levels of power can deliver 16, 20 amp circuits per panel. Crescendo does allow for a rigid wireway to be installed at every twelve inches of panel height. See Electrical Power Guidelines section (page 74) for maximum number of receptacles per infeed.

#### Power Infeeds

Power infeeds are available as base feed and top feed. Base infeeds fill one of the receptacle locations in the rigid wireway of a panel's base raceway. Each base must be specified as for left or right. All other levels of power that are not connected to the base level circuits must be fed from top feeds. Top feeds are run from the ceiling, through a power pole, through the notches in the ends of the horizontal rails, and then connected to the rigid wireway.

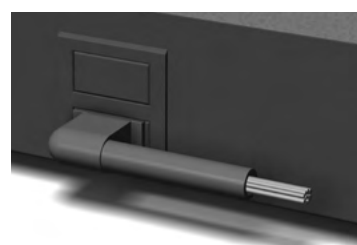
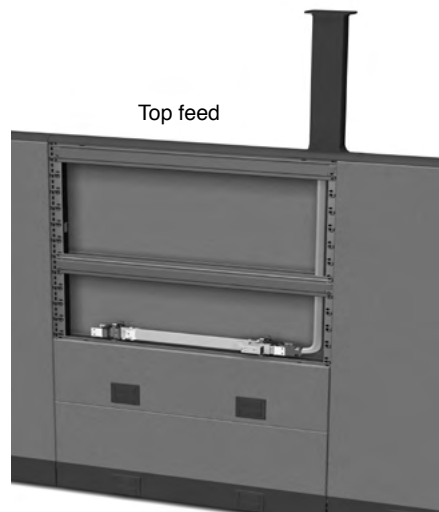
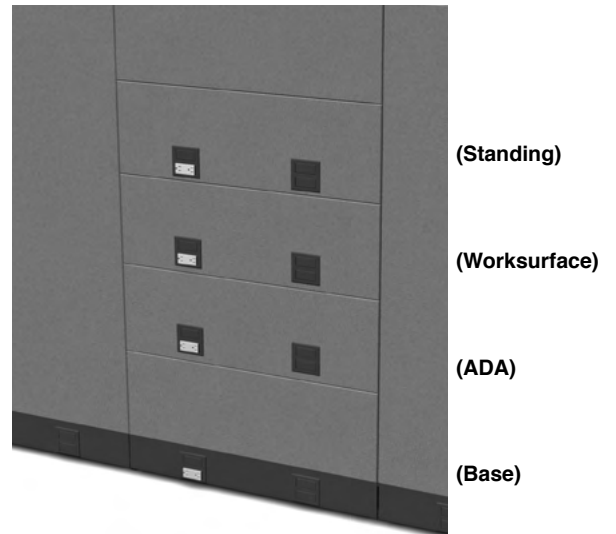

Base feed

# Planning Guidelines

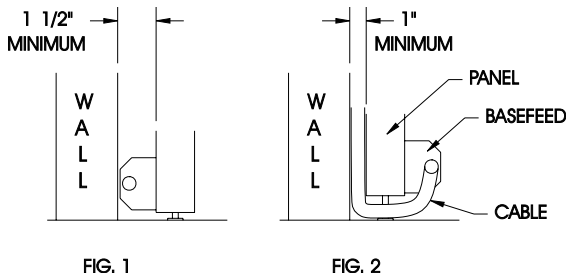

### Basefeeds

When a basefeed is going to be used between a panel and the building wall, the panels must be at least 1 1/2" away from the wall to provide clearance (See Fig. 1). If the panels must be tight against the wall, the basefeed can be connected inside the station and the 6' cable run under the panel. The panel run requires a minimum of 1" between it and the wall for the basefeed cable to enter the junction box on the wall (See Fig. 2).

If the panels must be tight against the wall, another option is to use an Open Tile on the bottom of the panel.

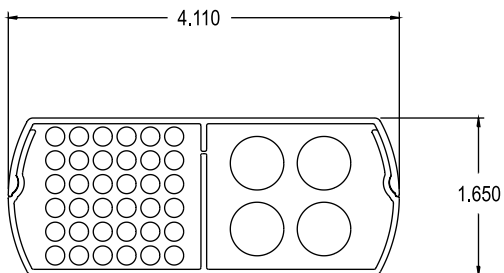

### Top Feeds to base level

Standard top feed comes with a 7' aluminum power pole to go from the top of the panel to the finished ceiling. Use criteria at left for specifying a standard power pole.

When the finished ceiling height exceeds the maximum ceiling height, and top feed must be used, a 10 foot long power pole kit can be used. (See note below). Use criteria at left for specifying a long power pole.

Note: Any application requiring a long power pole should be installed next to an intersection.

Standard 7' Power Pole	
Panel Height	Maximum Ceiling Height
30"	9'0"
42"	10'0"
54"	11'0"
66"	12'0"
84"	13'6"

Extended 10' Power Pole	
Panel Height	Maximum Ceiling Height
30"	12'0"
42"	13'0"
54"	14'0"
66"	15'0"
84"	16'6"

## Planning Guidelines

### ELECTRICAL POWER

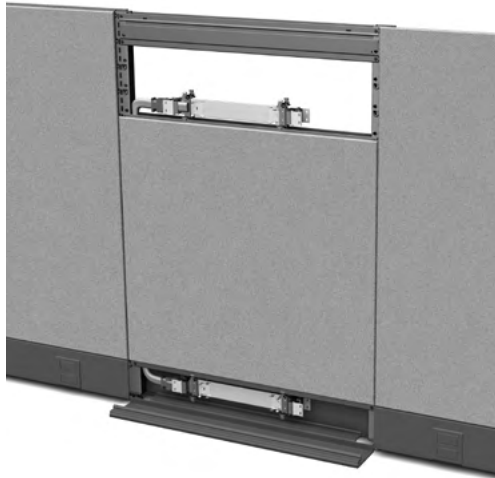

#### Rigid Wireways

Rigid wireways mount to horizontal rails in the panel with two nylon clips. Rigid wireways hang from the horizontal rail in the base raceway (the horizontal rail is upside down) and attach to the top of the rail at all other heights. Rigid wireways are used in conjunction with raceway tiles at all heights except at base level. Rigid wireways can accept power infeeds, horizontal panel to panel jumpers, vertical jumpers, and receptacles.



#### Horizontal Jumpers

Horizontal jumpers are used to pass power from panel to panel between the rigid wireways. There are two length jumpers available. The short jumpers are used for in-line conditions and 90° corner conditions, while the long jumpers are used to pass straight through a panel intersection.

# Planning Guidelines

## Horizontal Jumper Options Base Heights

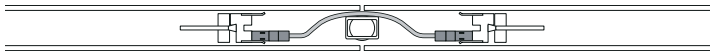

Panel to Panel Connection  
Use (1) Panel Jumper - 17

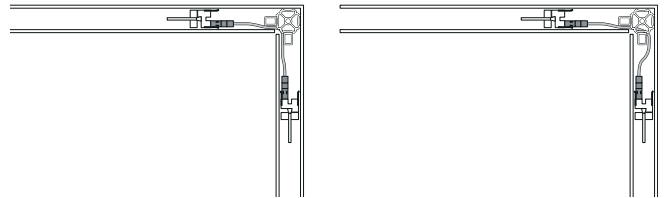

90° Corner: Use (1) Panel Jumper -20.  
Route Panel Jumper -20 either way shown above.

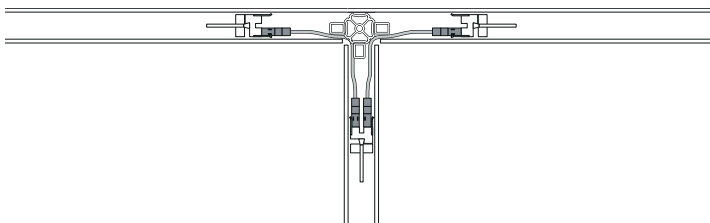

Two Inside 90° Corners  
Use (2) Panel Jumpers -20

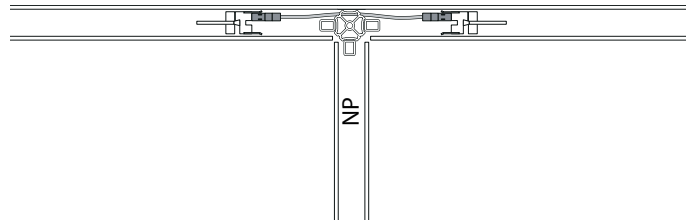

Three Way  
Use (1) Panel Jumper -20

## Horizontal Jumper Options Non-Base Heights

Note: A raceway tile (RWT) must be specified to allow the panel jumper to pass by the vertical posts.  
The vertical jumper will NOT fit between an accoustical tile (AT) and the vertical post.

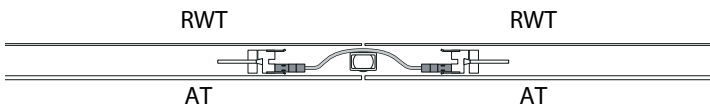

Panel to Panel Connection  
Use (1) Panel Jumper -17

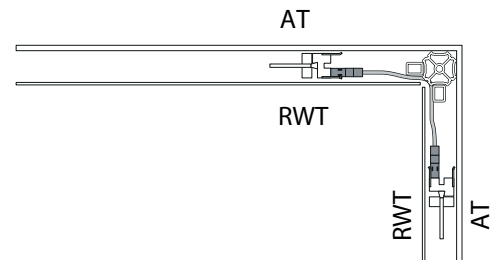

90° Corner  
Use (1) Panel Jumper -20

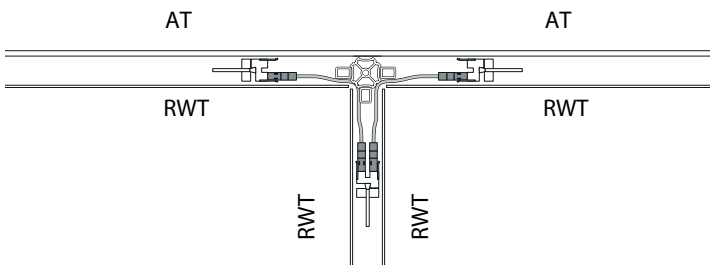

Two Inside 90° Corners  
Use (2) Panel Jumpers -20

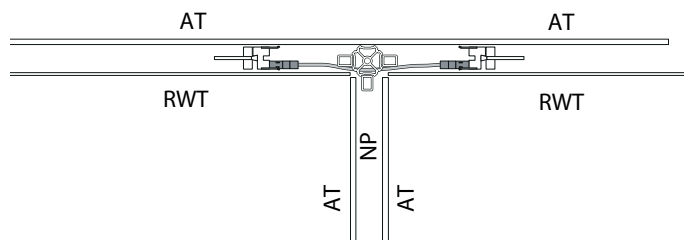

Three Way  
Use (1) Panel Jumper -20

## Planning Guidelines

### ELECTRICAL POWER

#### Vertical Jumpers

Vertical jumpers are used to pass power between various heights in a panel, through the notches at the ends of all horizontal rails. There are two length jumpers available. The long jumper is used to route power from the base to any height in the panel, while the short jumper is used to route power between two directly adjacent heights in a panel (ADA to worksurface height or worksurface height to standing height). When the long vertical jumper is used, any excess cable is stored in the cavity just above the base raceway. Vertical jumpers utilize round – shaped steel conduit.

Horizontal rails can be added and removed with the jumpers in place (unless both ends of a horizontal rail are filled beyond 50% capacity with cables and/or jumpers).

Note: Filling both notches of the rail with cables and/or jumpers beyond 50% capacity can “trap” the horizontal rail in place, making it difficult to reconfigure a panel without disturbing the cables.

#### Vertical Jumper Options

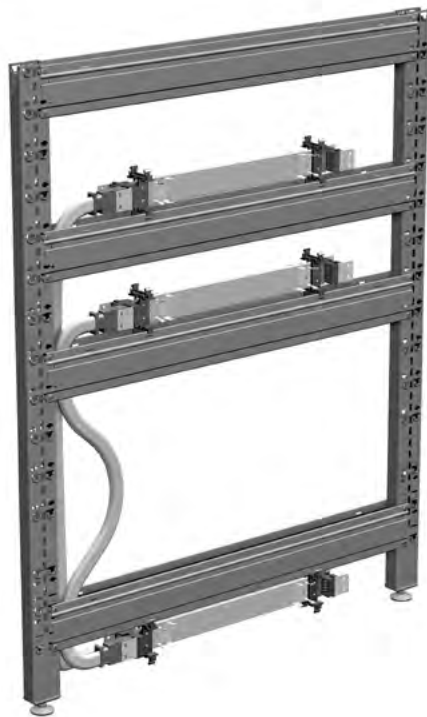

Long jumper



Short jumper



## Planning Guidelines

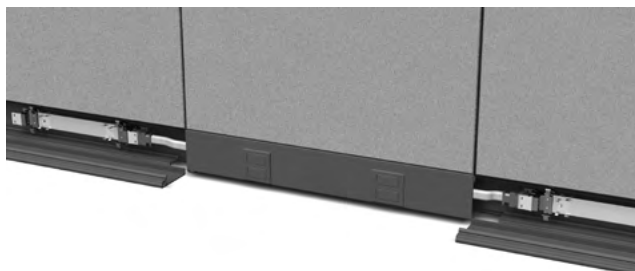

### **Power Pass Through**

Power pass through cables pass power from one rigid wireway, through a non-powered panel, to the rigid wireway of a third panel. These cables connect to the horizontal jumper from the rigid wireway of one panel, pass through the base raceway of the adjacent panel, and snap into the horizontal jumper connected to the rigid wireway of the next adjacent panel.

## Planning Guidelines

### ELECTRICAL POWER

#### Typical Power Pass Through Connections

Note: Power pass throughs (PPTs) are the same length as the rigid wireways and are connected to other powered panels or PPTs using the appropriate length panel jumpers. Jumpers are specified the same as they would if connected to power panels. The PPT specified is always the same "named length" as powered panels. EXAMPLE: A 36" non-powered panel uses a 36" PPT.

Note: For non base heights (ADA, worksurfaces, and stand-up) PPTs must be routed behind raceway tiles, they CANNOT fit behind acoustical tiles.

#### SAMPLES:

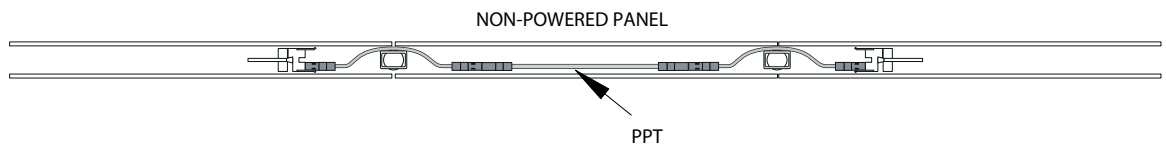

Drawing P.

Use (2) panel jumpers -17. Use (1) PPT the same "named length" as the non-powered panel.

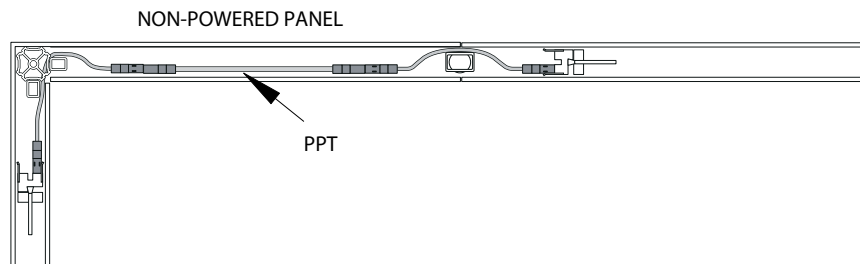

Drawing Q.

Use (1) panel jumper -17, use (1) panel jumper -20, use (1) PPT the same "named length" as the non-powered panel.

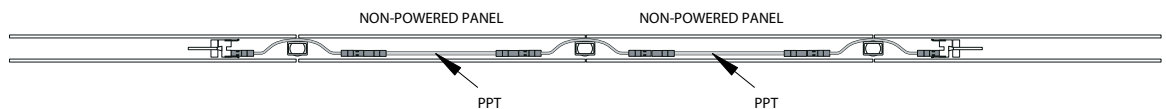

Drawing R.

Multiple PPT non-powered panels may be connected together by alternating the appropriate PPTs and panel jumpers.

#### 12" and 18" PPTs

Note: 12" and 18" PPTs require only one horizontal jumper. The other side of the PPT will plug directly into the rigid wireway.

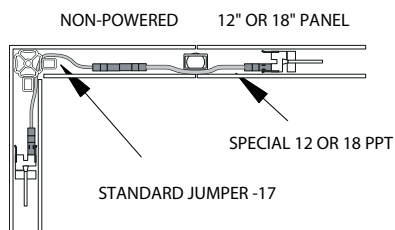

Drawing S.

12" and 18" PPT situations. Use (1) panel jumper (both around a corner or for adjacent in-line connections). Use (1) special PPT the same "named length" as the non-powered panel.

## Planning Guidelines



### Receptacles

Duplex power receptacles are snapped into place on the rigid wireway and can be used at any power height. Receptacles are labeled with the circuit number to which they are wired.

To access power in a panel, press fit the receptacle into position on the rigid wireway.

When accessing at base raceway level, remove the base raceway filler plate in the base raceway door and replace it with a bezel. Orient the bezel such that the open space is at the top of the bezel and the data filler plate is at the bottom.



When accessing at heights other than the base raceway, orient the bezel such that the open space is at the bottom of the bezel and the data filler plate is at the top.

## Planning Guidelines

### ELECTRICAL POWER Wiring Details

#### Circuit Wiring Details

The wiring configuration of the 6-2-2 electrical system is 6 conductors (12 gauge), 2 neutrals (10 gauge), and 2 grounds (12 gauge). All receptacles are rated at 15 amp, 120 volt capacity.

The following are standard building power sources and the method of wiring to the 8/10 electrical system.

Note: It is required by most state and local codes to have a licensed electrician connect the 8/10 electrical system to the buildings power source.

#### Power Infeed to Building Connections

Have a certified electrician hard wire the panel power infeed to the building power source according to the National Electrical Code and any other applicable local codes. See the connection diagrams for proper wiring connections to available power.

### Connection Diagram

## 810 WIRE ELECTRICAL 4-4-2 CONNECTION DIAGRAMS

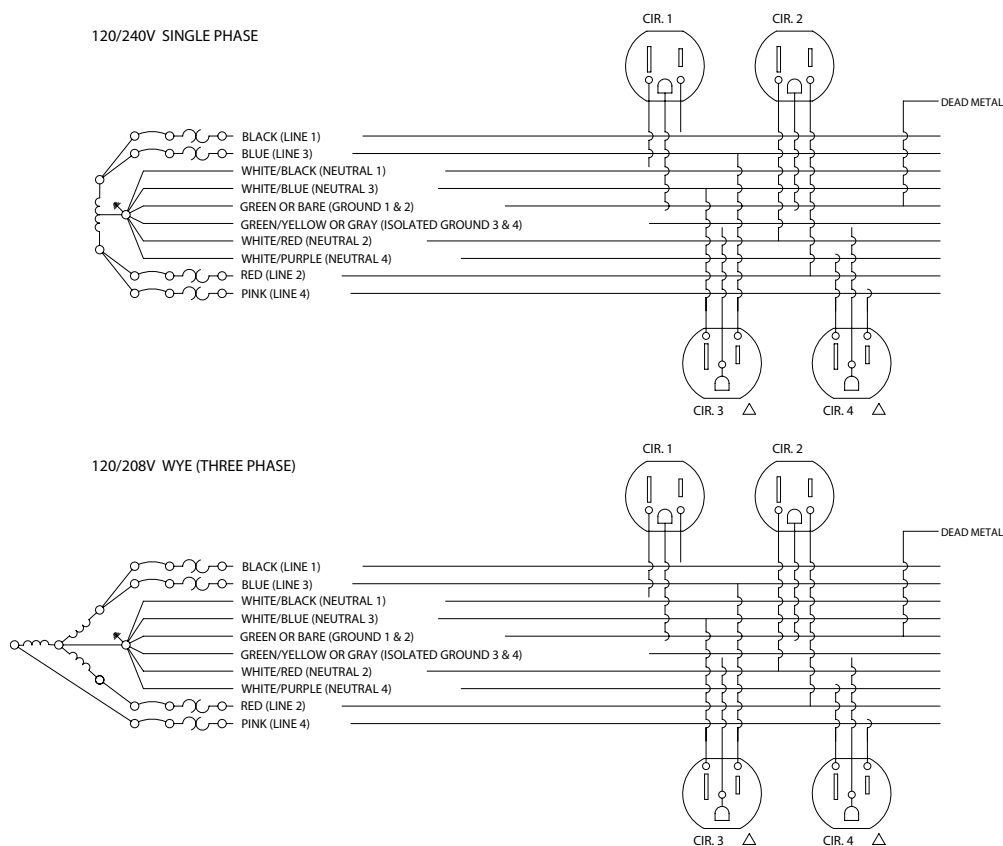

# Planning Guidelines

## 810 WIRE ELECTRICAL 6-2-2 CONNECTION DIAGRAMS

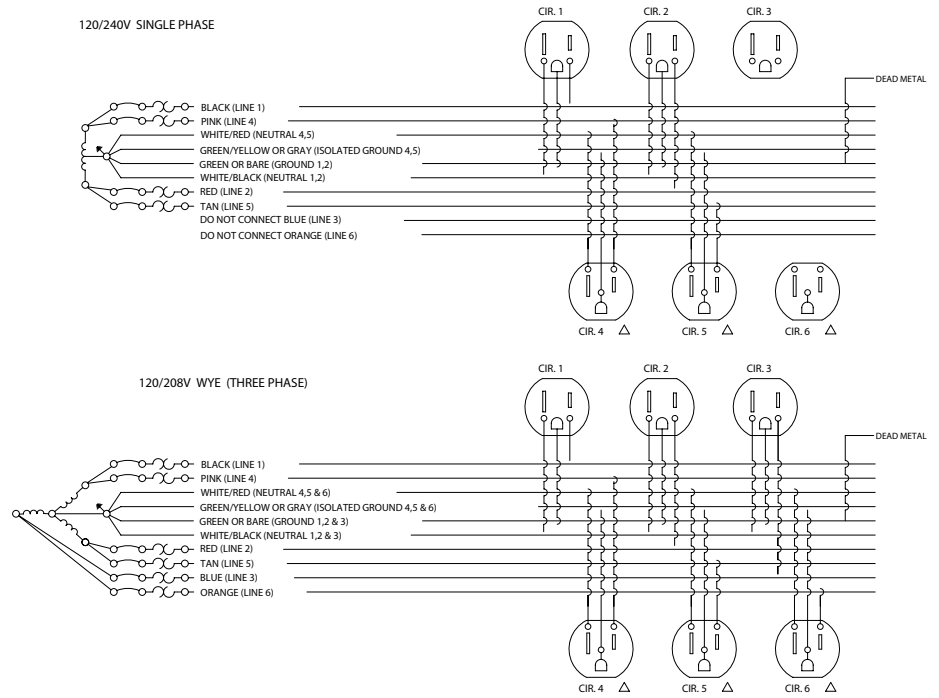

## 810 WIRE ELECTRICAL 6-2-2 CONNECTION DIAGRAMS TO AN 8-WIRE BUILDING

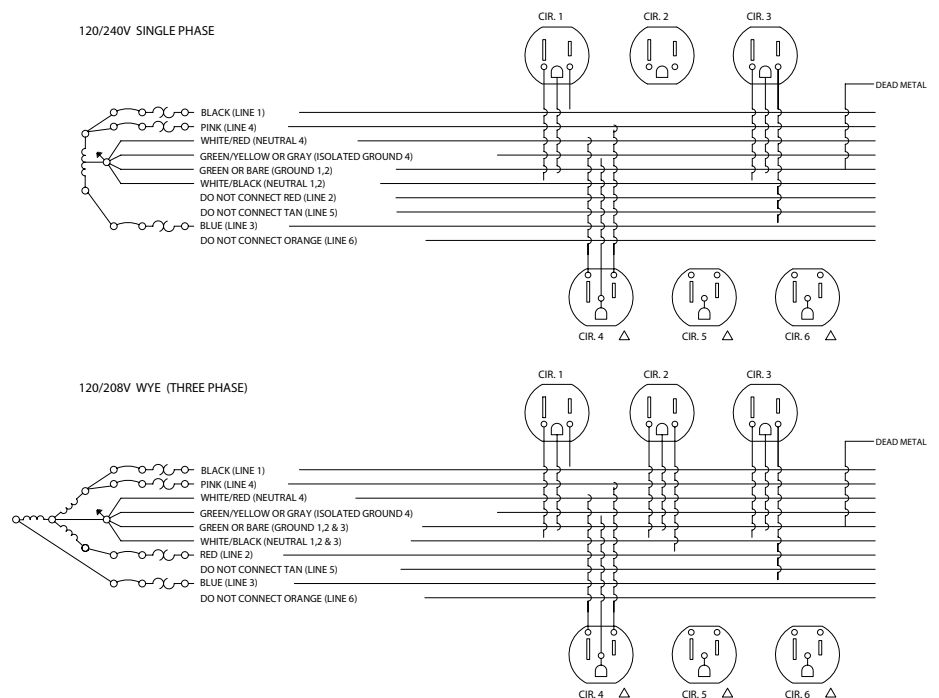

## Planning Guidelines

### ELECTRICAL POWER Chicago Instructions

#### Crescendo Panel Chicago (Hardwire) Electrical Installation Instructions

These instructions apply only to installing the Chicago Electrical (Hardwire) system into a Crescendo panel. To assemble the panel, refer to the panel installation instructions.

#### Tools Required

- A. Screwdriver
- B. Standard tools for wiring receptacles

#### Parts Included

- A. Mounting channel and hardware
- B. Junction box mounting bracket and hardware
- C. Junction box cover plate
- D. Junction box

#### Other Parts Required

- A. Receptacle (Leviton 5325 or equivalent)
- B. Other electrical components (Wire, conduit, fittings, etc.)

Note: The receptacle locations in a Chicago electrical panel are different than a standard panel. If Chicago electrical was not specified when the panel was ordered the Chicago electrical components will not work with the panel. To convert the panel to Chicago electrical, a new base raceway and raceway tiles need to be ordered.

#### Mounting channel installation

- A. The mounting channel can be attached to any horizontal rail on the panel.
- B. To install the mounting channel to the panel, position the channel with the open end in the same direction as the open end of the horizontal it is being mounted to (see Figure 1).

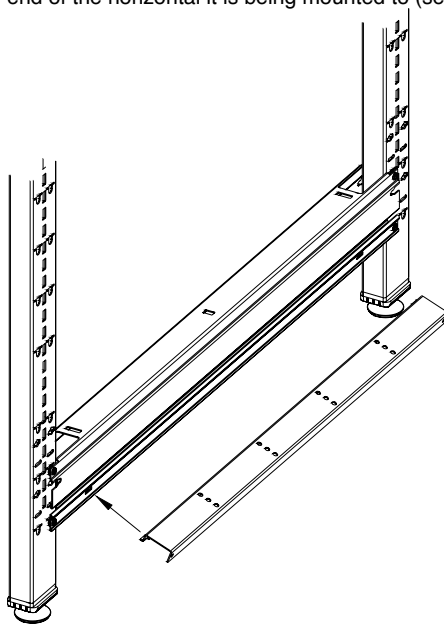

Figure 1

- C. Place the tabs on the channel into the corresponding slots on the horizontal channel and pivot the channel into place (see Figure 1).
- D. Secure the channel in place with the provided screws through the slots in the horizontal channel (see Figure 2).

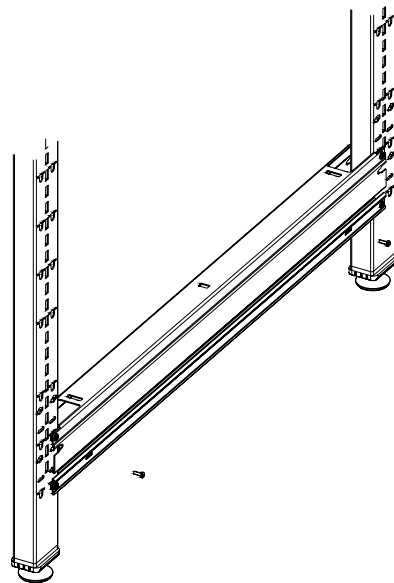

Figure 2

## Planning Guidelines

### Crescendo Panel Chicago (Hardwire) Electrical Installation Instructions (continued)

#### Receptacle Mounting (Figure 3)

- A. To mount a receptacle, first screw a mounting bracket to the mounting channel.
- B. Then screw the junction box to the mounting bracket.
- C. After all of the junction boxes have been positioned, run conduit between the junction boxes following all applicable codes.
- D. Wire and mount the receptacles into the required junction boxes; be sure to include a junction box filler plate behind each receptacle.

#### Bezel Installation (Figure 3)

- A. For base height power, remove the filler plates in front of the receptacles. For all other height power, trim the fabric away from the cutout in a raceway tile and knock out the steel blank.
- B. Snap power and data bezels in from the front of the raceway. Install a bezel filler plate or modular furniture data plate (supplied by others) into the unused hole of the power and data bezel.

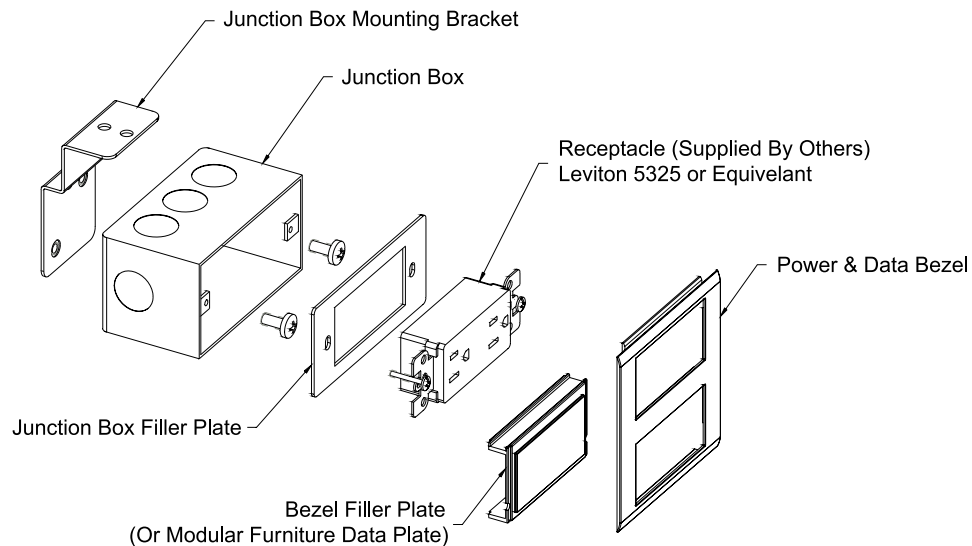

Figure 3

# Crescendo

## Planning Guidelines

### ELECTRICAL POWER New York City Infeed

#### Crescendo Panel New York City Power Infeed Installation and Adaptations

The City of New York has requirements for special power entry assemblies. Approval from the New York Department of Buildings, Bureau of Electrical Control, must be obtained prior to installation. A local qualified electrician will hardwire from the power entry box to the power source. New York City codes requires that all electrical components must be field installed. The New York City Power Infeed replaces the rigid wireway in the starter panel.

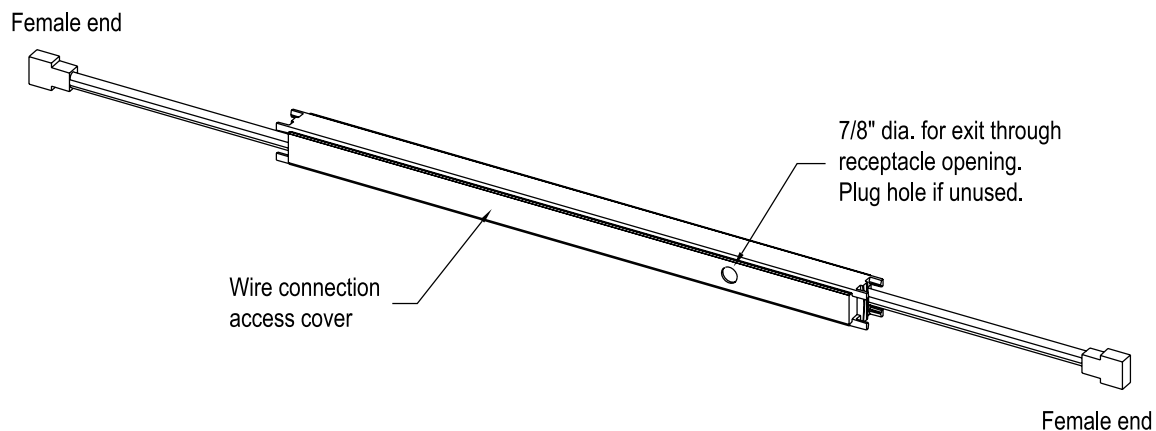

Strip or tuck in unused cable.

**CAUTION:** Extend connector(s) and plug to adjacent track(s) before shortening wires.

**Note:** Receptacles cannot be installed in the panel where the infeed is located. It is not possible to attach a vertical jumper to the New York infeed.



## Planning Guidelines

### ELECTRICAL POWER

#### Frequently Used Electrical Terms

**Volt:** Volt: The force that moves an electric current. The Universal electrical system utilizes 120 volts as standard.

**Amperes:** The amount of electrical current flowing in a circuit. The current is the voltage of the circuit divided by resistance (ohms) in the circuit.

The Universal electrical system is comprised of four circuits. Each circuit has a maximum current carrying a capacity of 20 amps at 120 volts.

Note: The National Electrical Code (NEC) recommends that continuous use circuits (used 3 or more hours per day) be loaded to only 80% of rated capacity. Therefore, computer labs should not exceed a 16 amp load per circuit, which is two to three computers.

**Wattage:** A watt is a unit of power (rate of doing work). It is a function of volts and amperes; i.e., a light bulb which is rated at 100 watts at 120 volts will draw .833 amps. OFG's 20 amp circuit can carry enough current for 24 of these light bulbs (NEC only allows 19).

**Circuit:** A complete electrical path; the purpose of which is to provide current to power electrical items.

**Hot wire:** That path of a circuit which is connected to the supply side of the power source (either generator or battery). This is the path that contains a fuse or circuit breaker. OFG uses six hot-wires in its 6-2-2 electrical system.

**Neutral:** That path of a circuit which is connected to the return side of the power source (either generator or battery). This path is connected to ground at the main service box. OFG uses two oversized neutrals in its 6-2-2 electrical system.

**Ground:** Ground path - a conductor used to conduct stray electrical current safely back to earth. A ground-wire is not required to complete a circuit; i.e., make a light bulb glow or a motor turn. OFG includes two ground-wires for safety purposes in its Universal electrical system.

**Isolated Neutral:** A neutral which is used for only isolated circuits. OFG has one isolated neutral in its Universal electrical system.

**Isolated Ground:** A ground which is used for only one circuit, this ground is specifically grounded to its own dedicated grounding rod. OFG has one isolated ground on its standard Universal electrical system.

**Isolated Circuit:** A circuit which has a separate hot, isolated neutral, and isolated ground, thereby causing it to be electrically separated from other circuits. There are up to three isolated circuits in its Universal electrical system. Some architects and facilities people state that all computers must be plugged into isolated circuits. This is not true because:

1) OFG's oversized neutral allows the harmonics of three circuits to cancel each other out (neutralize) to a net effect of zero.

2) Circuits that utilize all isolated neutrals tend to overheat because they don't cancel themselves out.

**Single Phase:** A type of circuit used primarily in private residence construction. The Universal electrical system can be wired to single phase. This allows four circuits, leaving out circuits number three and six.

**Three Phase:** A type of circuit used primarily in commercial construction. Main advantage is that motors run more efficiently on three phase than on single phase. The Universal electrical system can be wired to three phase. This allows for all four circuits.

**Five Wire Circuits:** Some commercial buildings have five wires in their walls instead of eight wires. The Universal electrical system can be wired to only five wires which will provide for three circuits, leaving out the isolated circuit.

Find out if the building has panel surge protection at the service. If not, a low cost solution would be to use retail available surge suppressors rated at 60 to 70 joules.

**Harmonics:** When current drawn by the load is at a higher frequency than 60 cycles. Personal computers tend to draw current at 180 cycles.

**NEC:** National Electrical Codes.

# Planning Guidelines

## ELECTRICAL

### Guidelines

Plan circuits based on the actual amperage draw of known equipment.

Be aware of the NEC requirement that limits circuit capacity to 80 percent (16 amps) for circuits with continuous operating loads (more than 3 hours, e.g. lighting, computers, etc.).

Accommodate unplanned needs and future expansion by being conservative in your initial circuit loading (12 to 16 amps per circuit).

Never exceed maximum capacities or local code limitations.

**KNOW YOUR LOCAL CODES!** They always take precedence.

Determine the equipment needs for any isolated ground circuits and plan circuit loading and power feeds accordingly.

As far as possible, try to balance loads between circuits. Plan a circuit load that is within 50 percent of the loads on the other circuits. (Balance does not apply to the isolated circuits.)

Place receptacles for known equipment only, never exceeding maximums allowed per code (13 duplexes per circuit, or local code restrictions, whichever is smaller).

If any single piece of equipment draws more than 60 percent of the available amperage of a circuit, it must be the only device connected to that circuit. Example: A copy machine draws 15 amps; therefore, nothing else can be connected to the circuit the machine is on.

Always have your electrical layout plans reviewed by a licensed electrician or electrical inspector to ensure that they meet all code requirements.

### Priority Sequence for Electrical Layout

1. Plan circuits based on actual amperage needs.
2. Plan for future growth and additions.
3. Consider and plan for large loads separately.
4. Balance loads across shared circuits.

### Typical Amperage Loads

*CAD Station .....	10.00 – 20.00
Calculator .....	.25
*Coffee Pot .....	8.50 – 15.00
Clock .....	.03
Radio .....	.03
Stereo .....	.33
Tape Recorder .....	.07
*Laser Printer .....	6.00 – 10.00
*Desktop Copier .....	10.00 – 15.00
Electric Eraser .....	.25
Fan .....	1.10
*Freestanding Copier .....	15.00 – 20.00
Pencil Sharpener .....	1.00
Task Light (4') .....	.67
Adding Machine .....	.35
Letter Opener .....	1.90
Dictaphone .....	.25
Fax machine .....	.50
Word Processor .....	1.50 – 3.00
Postage Meter .....	2.80
Tape Dispenser .....	1.80
Personal Computer .....	3.50 – 8.00
Desktop Printer .....	1.50 – 5.00
CRT .....	1.00 – 3.00
*Space Heater .....	12.50
Typewriter .....	1.50
Microfiche Reader .....	.85
Transcriber .....	.15
A.C. Adapter .....	.05
100-Watt Lamp .....	.80

\*Some appliances such as coffee pots, copiers, printers, and heaters consume most of the amperage available on a circuit. It is recommended that these devices be connected directly to the building power supply, leaving flexibility for other circuit planning.

### Loading Capacities Maximum Loan Rating

	Circuit	Per Distribution System
Circuits	1	4
Amps	20	80
Receptacles	13	52

# Planning Guidelines

## DATA CABLE MANAGEMENT

Crescendo panels allow data cables to be "laid in" horizontally throughout the panel to ease installation and reconfiguration of data cables. A panel in the middle of a run can be completely disassembled leaving all of the cables undisturbed. Data cable routing is most easily accomplished after the frame of the panel has been set up but before the tiles and trim are installed. Data cables can be managed in several locations in the panel: under the top trim, in the base raceway, behind acoustic tiles, behind raceway tiles and vertically through the ends of horizontal rails. A 66 inch high panel with four levels of power can manage 300 to 400, 4 pair UTP cables.

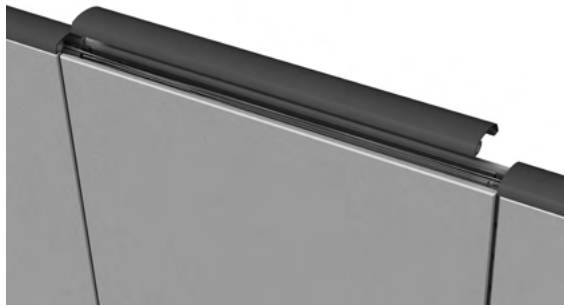

### Under the Top Trim

Data cables can be laid into the space under the top trim. Simply remove the top trim and lay the cables in place. Cable guides are available (purchased separately) to enforce a 1" minimum bend radius at 90° intersections (acoustical tile 90° cable guard). Cables are further protected in the top trough by the top trough cable guard, which is included as standard with every vertical post.

A total of 24, 0.20 dia, 4 pair UTP data cables can be run under the top trim.

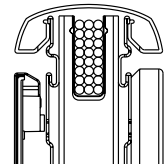

### In the Base Raceway

Cables can be laid into both sides of the base raceway. To open the base raceway, push down on the top of the raceway and swing the door towards the floor. If power is present, the data cables should be run in the space underneath the rigid wireways. A steel power/data separation septum that mounts between the vertical posts to provide separation between power and data, can be purchased separately.

Lay the cables in the raceway as required. To close the base raceway, simply close the door and it will automatically snap into place. Only one hand is required to open and close the door.

The base raceway with rigid wireway can hold 24, 0.20 dia., 4 pair UTP data cables per side for a total of 48. A base raceway without rigid wireway can hold 48 on each side for a total of 96.

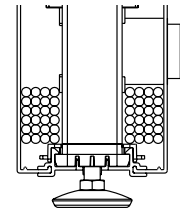

With rigid wireway

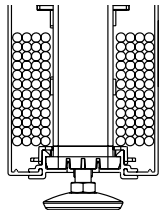

Without rigid wireway

# Crescendo

## Planning Guidelines

### DATA CABLE MANAGEMENT

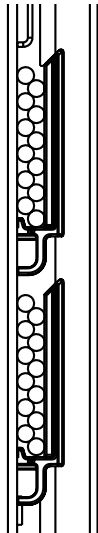
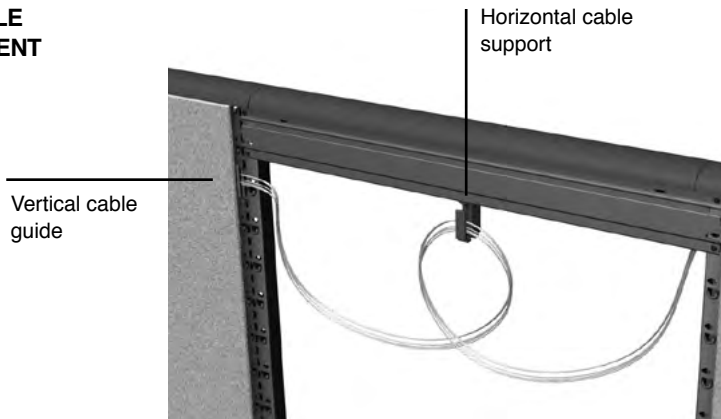

### Behind Acoustical Tiles

Data cables are managed behind acoustic tiles by using vertical cable guides and horizontal cable supports. Vertical cable guides hold and protect cables that run from panel to panel. Vertical cable guides also conceal the data cables as they are routed between tiles. A second type of cable guide insures that a one inch bend radius is maintained. Acoustical tile horizontal cable supports help support the cables in the center of a panel, as well as allow excess loops of cable to be hung from them.

Each vertical cable guide behind an acoustic tile can hold twelve, 0.20 dia. 4 pair, UTP data cables.

Refer to page 78 for the total number of vertical cable guides allowed for each tile height. Each side of the horizontal cable support can hold 12, 0.20 dia. 4 pair, UTP data cables, which is the equivalent of the capacity of one vertical cable guide. One of the "one inch radius" cable guards protects cables on the inside of a 90° corner while the other is used in all other conditions. The guards snap into the slots on the vertical post.

Before routing cables, snap the vertical cable guides into the vertical posts and twist the horizontal cable supports into the horizontal rail or gang them to each other, at the desired height. Plan carefully to be sure worksurfaces and overheads will not limit your future access to the cables. Refer to Cable Guide Diagram on page 78. Once the guides and supports are in place, the cables can be laid in.

It is advisable to store excess loops of cable in every other panel to allow for expansion and reconfiguration.

# Planning Guidelines

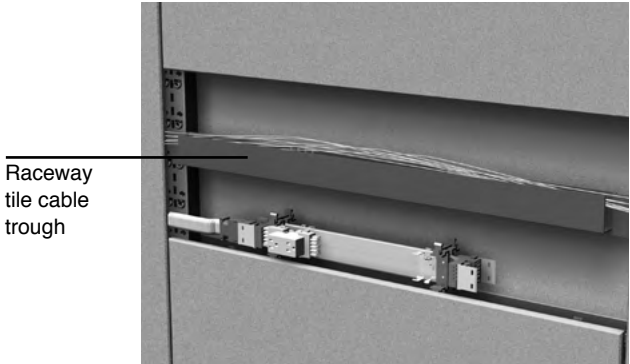

### Behind Raceway Tiles

All raceway tiles include a steel cable trough, which hangs in the slots in the vertical posts. This cable trough is hung near the top of the raceway tile to allow enough room below it to mount a rigid wireway to the horizontal rail. Cables are simply laid into the trough. Convenient slots and holes are included in the trough to secure cables that are terminated at data connectors located in the same bezel as the power duplex receptacles.

The raceway tile is shipped completely upholstered and includes flexible end pieces which conceal all power and data cables as they are routed between tiles.

Each bezel includes one filler plate which can be snapped out, turned around, and snapped back into place to allow cables to exit the panel without the need for a data connector and face plate. The filler plate can also be removed and be replaced with a modular furniture data face plate. See the Data Cable Management Planning Guidelines for typical manufacturers of these data face plates.

A total of 24, 0.20 dia. 4 pair, UTP data cables can be routed in the cable trough behind a raceway tile. If a rigid power wireway is not used with a raceway tile, then two cable troughs can be utilized which allows for a total of 48, 0.20 dia. 4 pair UTP data cables behind a raceway tile.

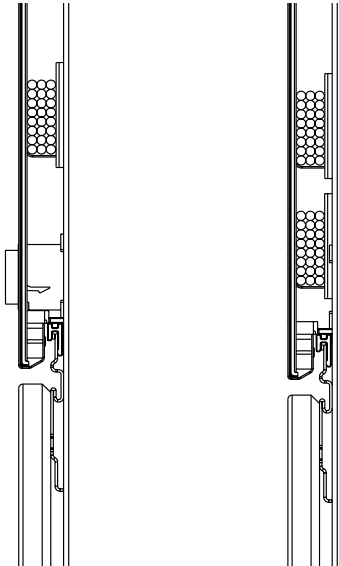

With rigid wireway

Without rigid wireway

### Vertically Through Horizontal Rails

Cables can be managed vertically within a panel along the interior sides of the vertical posts. Cables are straddled by the notches cut into the ends of all horizontal rails. A cable guard is available for the notch of the horizontal rail to enforce a 1" minimum bend radius as the cable moves from a horizontal to vertical direction.

Horizontal rails can be added and removed with the cables in place (unless both notches of a horizontal rail are completely filled with cables). At least 24, 0.20 dia, 4 pair UTP data cables can be routed through each notch of a horizontal rail. Twenty four cables represent approximately 50% fill capacity of each notch.

Note: Filling both notches of the rail beyond 50% capacity can "trap" the horizontal rail in place, making it difficult to reconfigure a panel without disturbing the cables.

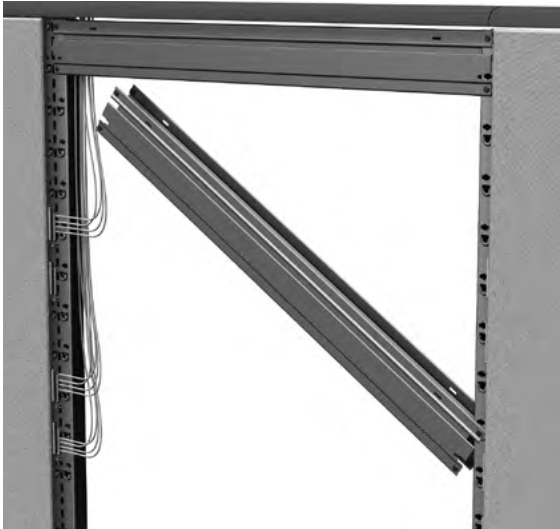

# Crescendo

## Planning Guidelines

### DATA CABLE MANAGEMENT

### Cable Management Capabilities

Cable management capabilities within panel and frame shall be as follows:

Page	Size	Location	4 Pair UTP 0.20 Dia.	4 Pair UTP 0.16 Dia	25 Pair	
71	.65 x 1.90	Top Trough	24	32	10	
			Side 1	Side 2	Side 1	Side 2
72	.31 x 2.0	Acoustic Tile Vertical Cable Guide	12	12	6	6
73	1.16 x 2.45 per trough	Raceway Tile w/power	24	24	12	12
73	1.16 x 2.45 per trough	Raceway Tile w/o power	48	48	24	24
71	.98 x 3.4	Base Raceway	24	24	12	12

The following shall be the number of vertical cable guides that fit vertically behind an acoustic tile:

Acoustical Tile Height	Maximum # of Vertical Cable Guides
12"	2
18"	4
24"	6
30"	8
36"	10
42"	12
48"	14
54"	16
60"	18
66"	20
72"	22
78"	24

#### For example:

12" high acoustical tile can use two vertical cable guides. Each guide can hold 12 - 4 pair UTP .20 dia. cables for a total capacity of 24 ( $2 \times 12 = 24$ ).

Lay-in cabling shall be supported throughout the panel. Cabling shall never be threaded through cutouts in frame. Panel horizontal rails shall be removable to allow for removal of vertically run cables within a panel.

## Planning Guidelines

### Notes on Reconfiguration

It is common while installing cable to store excess cable in the form of loops within some panels to allow for future reconfiguration of panels and workstations. Crescendo supports this practice by providing two ways to store extra cable inside of the panel. Loops of cable can be hung from horizontal cable supports behind acoustical panels or set into the opening of horizontal rails.

Panels can also be reconfigured without disturbing the cables. Cabling is always laid-in when cables are run horizontally in the system. This allows cables to be pulled out at any point along a run without having to disconnect cables from computers, printers, telephones, etc. The way in which cables are managed vertically through the panels allows horizontals to be added and removed without disturbing the cables. When a horizontal is removed, the notch at the end of the rail is open allowing the cables to remain undisturbed.

See the Reconfiguration section of this guide (pages 41-51) for specific examples.

### Base and Tile Raceway Data Access

Crescendo standard power and data bezel in base raceways and raceway tiles supports access to data cables in two ways. The bezel has two rectangular openings for power and data access. One opening is used for a duplex power receptacle, and the other is covered with a removable filler plate. This filler plate can be snapped out, reversed in position, and snapped back into place to allow cables to pass through the base raceway or raceway tile without terminating at a data connector in a modular face plate. The filler plate can also be removed and replaced with a modular furniture data plate. These plates are supplied by most major data connector manufacturers and are designed to snap into one or both of the openings in the power/data bezel. UNICOR does not provide the modular faceplates or data jacks.

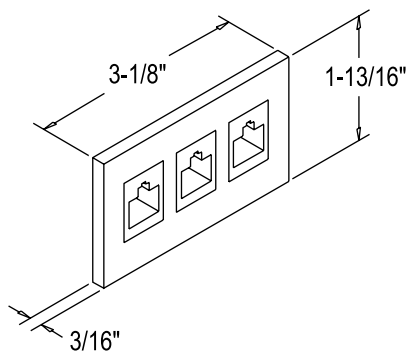

"Typical" Data Plate Dimensions

\*Data openings are 1.375" x 2.700".

# Crescendo

## Planning Guidelines

### DATA CABLE MANAGEMENT

#### DATA PORT OPTIONS

Furniture Opening Size: 2.700"w x 1.375"h



Manufacturer	Model Number	Ports	Style
AMP (Tyco)	1375288-x	4	Flush
	558106-x	2	Flush
	558107-x	3	Flush
Systimax (Commscope)	M13C-x	3	Flush
	M13CLS-x	3	Flush
Panduit	CFFP4x	4	Horizontal
	CFFPL4x	4	Horizontal
	CFFPA2x	2	Horizontal
	CFFPE3x	3	Horizontal
	CFFPLA4x	4	Vertical
	UICFFP4x	4	Vertical
Siemon	MX-MFP-x (not available in colors 02 or 80)	4	Horizontal
	CT-MFP-x (not available in colors 02 or 80)	2	Horizontal
Leviton	49910-Sx2	2	Angled
	49910-Sx4	4	Angled
	49910-Ex4	4	Angled
Hubbell	FMPS12B	2	Flush
	FMPS12BVD	2	Flush
	FMPS13B	3	Flush
	FM5E4A	4	Flush
	FM5E4I (Black)	4	Flush
	FMPS12G	2	Raised Modular
	FMPS12GVD	2	Raised Modular
	FMPS13G (Gray)	3	Angled
Ortronics	40700071-x	3	Trac Jack (Flush)
	42100009-x	3	Trac Jack (Flush)
	40700072-x	3	Trac Jack (0.625 Deep)
	42100009-x	3	Trac Jack (0.625 Deep)
	40700073-x	3	Trac Jack (1.0 Deep)
	42100009-x	3	Trac Jack (1.0 Deep)
	40300633-x	4	Trac Jack (1.5 Deep)
	40300167-x	2	Series II (Black)

*x - denotes color option*

Chart provides data port options only. The customer is responsible to confirm the data line compatibility/requirements with these proposed data ports for their specific project. These items need to be ordered separately and are not included in the systems furniture package.

We do not specifically recommend any brand/model number. All info is accurate as of the published date. Customers should always check current manufacturer's specs for compatibility.



# Planning Guidelines

## DATA CABLE MANAGEMENT

### Vertical Cable Guide Diagram

Use the Vertical Cable Guide Diagram below to determine the recommended placement of vertical cable guides based on your reconfiguration. Also note the typical number of data cables and possible locations for the cables on a panel that also supports an overhead cabinet or shelf, tackboard, tool rail, and worksurface.

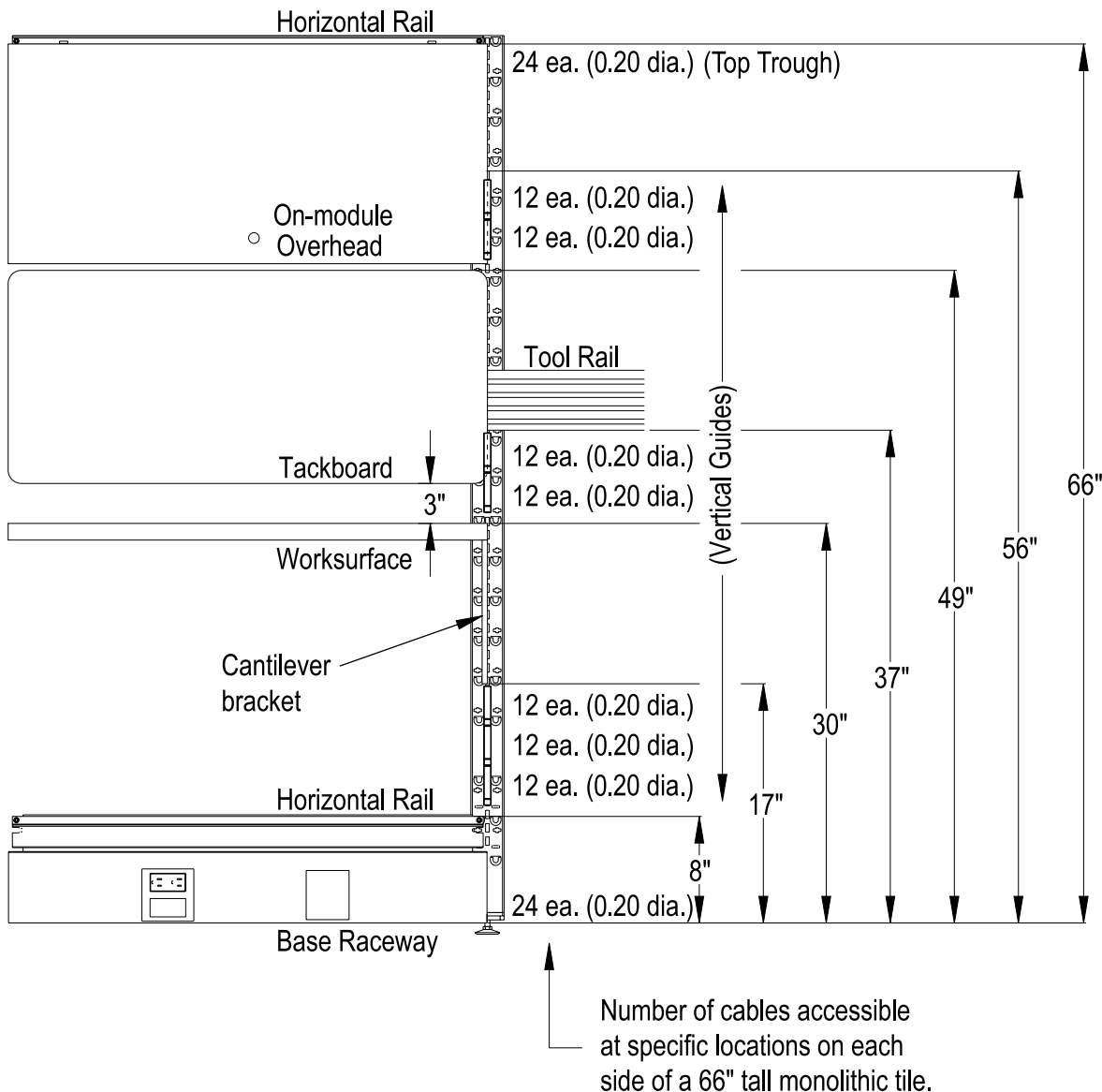

## Planning Guidelines

### Frequently Used Data Terms

**Category:** Three, Four, Five - Standards developed by EIA/TIA for Building Telecommunication Cabling System. Applies to cables, connecting hardware and installation.

**UTP:** Unshielded Twisted-Pair Cabling System

This is where the category designation first started. Cat 3, 4, & 5 first applied only to cables.

Most common Cat 5 cable is four pair.

**RJ:** Remote Jack.

**RJ45:** Connector used for four pair cable. Available in Cat 5. Used mostly for computers.

**RJ11:** Connector used for three pair cables. Not available in Cat 5. Used mostly for telephones and modems.

**Data Line Voltage:** Voltage in data cables varies according to the hardware manufacturer; i.e. IBM, Hewlett Packard, DEC, Wang.

Voltage usually changes continually in data lines but is always around one volt.

**Line Loss:** Loss of signal due to resistance of length of cable and number of connectors. Category 5 guidelines prevent line loss.

**Fiber Optics:** Method of transferring data through a glass filament. Data is carried via light. No electricity, no EMI. Impervious to electrical noise. Bending of the cable is critical. Usually can't have a bending radius of more than 4".

**EMI:** Electro Magnetic Interference. The condition that exists when the electric field of a conductor interferes with the signal of a data carrying conductor.

### Basic Rules for Compliance with Cat 5

- 1) Use verified cable "UTP" (will be marked on the cable jacket)
  - Four Pair
  - Different Twist Patterns i.e. 1/2", 5/8", 3/4", 1"
- 2) Use Category 5 designated connecting hardware
  - RJ45 - on the front
  - Must be marked CAT 5 on the piece itself
  - AT&T 100 type contacts on the rear
- 3) Use Category 5 Patch cables (from equipment to patch panel)
- 4) Install to Category 5 standards
  - a) No more than 1/2" of the untwisted wire at the point of termination. This prevents "Near End Cross Talk": (NEXT)
  - b) Keep UTP cabling away from sources of EMI: fluorescent lights, electric panels, light dimmers, electric motors
  - c) Length of horizontal wiring should not exceed 295 feet.
- 5) Always check with local codes prior to installation.

## Technical Specifications

### PANELS

#### Fabric Panels

Panels available with Noise Reduction Coefficients of .65 and .80 in heights of 30", 42", 54", 66", and 84". The panel widths offered shall be 12", 18", 24", 30", 36", 42", 48", 54", and 60". All panels of 24-60" wide can readily accept electrical components. The panel shall be 3.5" thick.

The modular office systems acoustical properties will have been tested at independent laboratories using random production samples. The acoustical properties shall be determined by using the following testing procedure: Noise Reduction Coefficient (Test Method ASTM C-423). The standard acoustical panel tiles shall have an NRC rating of at least .65. The highly acoustic panel tiles shall have a rating of .80.

#### Vertical Posts

Full posts (used in-line & end-of-run) shall be available in heights of 30", 42", 54", 66" and 84" and include a glide that allows 4" leveling adjustment. Shall be constructed of 16 gauge cold rolled steel CRS with a black E-coat finish. Shall contain slots in 1" increments to allow component hanging and formed out pockets accept rivets of horizontal rails.

Stackable full post (used in-line & end-of-run) shall be available in heights of 12", 18" and 24" and include an extruded aluminum stacking splice to stack on full post. Shall be constructed of 16 gauge CRS with a black E-coat finish. Shall contain slots in 1" increments to allow component hanging and formed out pockets accept rivets of horizontal rails.

Half posts (used at intersections) shall be available in heights of 30", 42", 54", 66" and 84" and include a glide that allows 4" leveling adjustment. Shall be constructed of 16 gauge CRS with a black E-coat finish. Shall contain slots in 1" increments to allow component hanging and formed out pockets accept rivets of horizontal rails.

Stackable half posts (used at intersections) shall be available in heights of 12", 18", and 24" and include an extruded aluminum stacking splice to stack on half post. Shall be constructed of 16 gauge CRS with a black E-coat finish. Shall contains slots in 1" increments to allow component hanging and formed out pockets accept rivets of horizontal rails.

Integral glide shall provide 4" height adjustment. Shall be mounted to post with an injection-molded housing.

Integral light block shall be constructed of .030 black chipboard and include black, injection-molded wire protector and top cut-out.

#### Horizontal Rails

Horizontal rails shall be constructed of 16 gauge CRS with black E-coat finish, and eight rivets per horizontal member to attach to vertical members. Shall be offered in lengths of 12", 18", 24", 30", 36", 42", 48", 54", and 60" with mounting holes to accept electrical wireway in 24" and wider rails. Shall contain an integral off-module component hanging track.

#### Fabric Acoustical Tiles

Tile upholstery shall be stretched over the frame and adhered to perimeter of tile. Tiles shall hang on frame by an injection-molded hook. Connection shall interlock horizontal frame member to vertical member. Tiles are field replaceable.

.65 Noise Reduction Coefficient upholstered tiles shall be constructed of 20 gauge, prefinished steel. Frame shall be joined together by injection-molded corner blocks, and spot welded in place. Core shall consist of 7/16" thick perforated mineral fiberboard and 3/8" thick fiberglass overlay.

.80 Noise Reduction Coefficient upholstered tiles shall be constructed of 20 gauge, prefinished steel. Frame shall be joined together by injection-molded corner blocks, and spot welded in place. Core shall consist of 7/16" rigid fiberglass board and 3/8" thick fiberglass overlay.

#### Raceway Tiles

Raceway tiles shall be fabric wrapped. Fabric shall be adhered to face of tile. Raceway tiles shall be constructed of 20 gauge steel. Raceway tiles 24" and wider shall contain knockouts to accept receptacle and data jacks. Shall include steel trough for data cabling. Injection-molded ends shall mount tile to panel and provide flexible seal to conceal cables between tiles. Shall be available in 12" height only and widths of 12", 18", 24", 30", 36", 42", 48", 54", and 60".

## Technical Specifications

### PANELS

#### **Glass Tiles**

Glass tiles shall be constructed of an extruded aluminum frame. Frame shall be joined together by steel corner bracket plates and screwed into place. Glass shall be supported by PVC extrusion which slides into the aluminum frame. Shall be available in heights of 12", 18", 24", 30", 54", 66", and 84" and widths of 12", 18", 24", 30", 36", 42", and 48". Glass shall be 1/4" thick tempered or tinted.

#### **Open Tiles**

Open tiles shall be constructed of an extruded aluminum frame. Frame shall be joined together with steel corner brackets plates. Shall be available in heights of 12", 18", 24", 30", 42", 54", 66", and 84" and widths of 12", 18", 24", 30", 36", 42" and 48".

#### **Base Trim/Raceway**

All base trim/raceways 24" and wider shall readily accept electrical rigid wireways and data cables. The base raceway shall consist of two doors (one on each side of the panel). Each door shall be hinged to raceway bottom with integral living hinge and held in place with injection-molded base lock. Base shall snap onto vertical post glide housing. Shall ship standard with filler plates, which are easily removed to accommodate electrical receptacles and/or data jacks. Doors and bottom shall be .080 thick PVC.

## Technical Specifications

### PANEL TRIM AND ACCESSORIES

Panel-to-Panel Connectors - The panel-to-panel connector must be universal for simplicity in specification and inventory. In-line connections shall include a full vertical post shared between two panels. 90° Intersections (2-way, 3-way, & 4-way intersections) shall include a half post which bolts into an extruded aluminum connector block. Open portions of universal connectors can accept universal corner trim.

#### Top Cap

All panels shall have a top trim cap made from rigid PVC with trim color permeating throughout the entire part with textured surface to hide fingerprints. Installation of top cap shall be a press fit without the use of tools. The top cap shall extend the full width of the panel.

#### Universal Corner Trim

Universal corner trim shall be constructed of .080 thick extruded PVC with integral flexible seal. Shall snap into open portions of corner connector block. Trim shall be extruded PVC with the trim color permeated throughout the part or fabric covered.

#### Variable Height Universal Trim

Variable height universal trim shall be constructed of .080 thick extruded PVC with notch to provide clearance for horizontal rail on lower height panel. Shall snap into open portions of corner connector block. Trim shall be extruded PVC with the trim color permeated throughout the part or fabric covered.

#### Adjustable Wall Mount

The adjustable wall mounts shall consist of a formed steel channel enclosed in a steel "U" channel to allow panels to be attached to existing building walls. This unit shall have a total adjustable depth of 1 1/4". Method of attachment to the existing building depends on the existing wall construction.

#### Panel End Caps

All exposed ends of a panel run shall be covered with an end-of-run cap. End-of-run caps shall be made from extruded rigid PVC with the trim color permeated throughout the part and shall be satin-textured to hide fingerprints. End caps shall be installed using a press fit method and require no assembly or disassembly tools. Panel end cap lengths shall correspond to panel heights. An end-of-run top cap shall be included with each panel end cap.

#### In-Line Variable Height Panel End Caps

All exposed ends of vertical posts shall be covered with a vertical trim cap when in-line panels are of different heights. Panel end caps shall be made from extruded PVC with the trim color permeated throughout the entire part and satin textured to hide fingerprints. End caps shall be installed using a press fit method and require no assembly or disassembly tools. Panel end cap lengths shall correspond to the different panel heights. An end-of-run top cap and bottom cap shall be included with each end cap.

#### 2-Way Caps

Injection molded 2-way caps shall be available for spanning the gap when panels are assembled requiring a 2-way cap. The trim color shall permeate throughout the entire part.

#### 3-Way Caps

Injection molded 3-way caps shall be available to cover the gap that exists when 3 panels are connected at right angles. The trim color shall permeate throughout the entire part.

#### 4-Way Caps

Injection molded 4-way caps shall be available to cover the gap that exists when four panels are connected to each other at 90°. The trim color shall permeate throughout the entire part.

#### Off-Module Panel Mount

An off-module panel mount shall allow a panel to be connected at 90° along an adjoining panel at any point. Can be made at any height where a break in tiles exists. Does not allow for the transfer of power.

#### Door

Panel doors shall be available in 42" width and 84" height to provide visual and acoustical privacy. Panel door shall mount to an 84" high panel. The construction of the door shall be corrugated cardboard honeycomb wrapped by hardwood stiles, MDF rails, faced with hardboard and covered with high pressure laminate. The frames shall be powder-coated aluminum to match panel frames. The door shall be available non-locking or locking.

## Technical Specifications

### ELECTRICAL

The factory installed US standard electrical system supplied for the modular office system shall be an 8/10 electrical system. This design consists of either 6 hot wires, 2 neutral wires and 2 ground wires – (6-2-2), which provide 6 separate 20 amp circuits or 4 hot wires, 4 neutral wires, and 2 ground wires – (4-4-2) which provide 4 separate 20 amp circuits.

#### Power Options

Power shall be supplied through an 8/10 electrical system. For power at heights other than base height, the panel must be specified with a raceway tile at the appropriate height. Raceway tiles at least 30" in width shall allow for the mounting of up to two duplex receptacles per tile (24" width shall allow one per tile). Rigid wireway can be mounted to any horizontal rail and snaps in with injection-molded clips. Power shall be available at the following heights:

- a. Base-Height Power - found in the 6" base raceway of the panel. Accepts US Standard receptacles.
- b. ADA-Height Power - The fabric covered raceway tiles shall allow for installation of ADA Height receptacles. In accordance with ADA requirements, receptacles are located at 20" from the base of the panel.
- c. Worksurface-Height Power - The fabric covered raceway tiles shall allow for installation of worksurface height receptacles. Two duplex receptacles can be mounted in a tile. Receptacles are approximately 32" high.
- d. Stand-up-Height Power - The fabric covered raceway tiles shall allow for factory installation of stand-up height receptacles. Two duplex receptacles can be mounted in a tile. Receptacles are approximately 44" high.

#### Panel Rigid Wireway

A rigid one-piece wireway shall be attached to the horizontal rail by two injection-molded clips. The wireway design shall allow for the snap connection of the rigid wireway of one panel to another through the use of panel jumpers. All panels 24" and wider are ready to accept electrical components.

#### Base Infeeds

The electrical system shall permit power infeed along the base raceway of the panel. Base feed power shall feed into the rigid wireway of the panel raceway. The base feed shall be constructed of a 6' long 1/2" liquidtight flexible metal conduit that contains ten wires with a receptacle type design allowing for quick installation and removal. The infeed shall be specified as left or right configuration.

#### Top Infeeds

The electrical system shall permit power infeed through the top of the panel. The top feed assembly shall consist of a 7' extruded aluminum power pole, top cap and ceiling trim and 12' flexible conduit containing ten wires to span the ceiling with a snap fit attachment for connection to the rigid wireway. The interior of the power pole shall be divided for power and communication management.

#### Data Top Feed

The data top feed consists of a 7' aluminum extruded power pole, top cap, and ceiling trim pieces, but does not include power infeed wiring.

#### Power Pass Through

The electrical system shall provide for a method of passing power from one powered panel through the raceway of a non-powered panel and connected to the powered rigid wireway of the next panel. This power pass through shall attach from the one powered panel to the next with a snap fit connection that requires no tools for assembly.

#### Receptacles

The receptacles for the modular electrical system shall be injection molded components which press fit into the rigid wireways of the panels. The rated capacity of the duplex receptacles shall be 15 amps.

#### Electrical System Test Requirements

The panel system, including the modular US electrical components, shall be listed to applicable UL standards and requirements by Underwriters Laboratories, Inc.

## Technical Specifications

### WORKSURFACES AND ACCESSORIES

Worksurfaces shall be available with high-pressure laminate and three edge styles. Surface shall be constructed of a 45 pound density particleboard core. The laminate worksurface cores shall be encased in a .028" phenolic backer and a .030" face sheet of high-pressure laminate. Laminate worksurface edges shall be trimmed with either a 2mm PVC edge banding, extruded flat vinyl T-molding, or an postformed/elliptical front edge with color matched .024" vinyl edge banding on all other edges. All worksurfaces with a flat vinyl T-edge shall be pre-drilled for cantilever brackets and hanging pedestals. Corner surfaces shall be pre-drilled for keyboards. The 60" wide surfaces shall have an integrated steel reinforcement to allow adequate support for load bearing. Worksurfaces 60" and wider shall include additional left-hand cantilever bracket. The worksurface shall be supported by one piece 14 gauge steel cantilever brackets. These brackets shall prevent dislodgment by the use of an integral top bracket tooth.

#### Rectangular Worksurfaces

The standard rectangular worksurface shall be offered in widths of 24", 30", 36", 42", 48", 54", 60", 66", 72", 78", 84", 90", and 96". The worksurfaces shall be offered in 24" and 30" depths.

#### Mitered Worksurfaces

Mitered worksurfaces shall be offered in 24" and 30" depths with widths of 30", 36", 42", 48", 54", 60", 66", 72", 78", 84", 90", and 96". (NOTE: 30" deep surface with 24" and 30" widths not available). The mitered worksurface is not available with a flat vinyl T-molded edge.

#### 90° Corner Worksurfaces

The 90° worksurfaces shall be available in: diagonal, curvilinear, dual curvilinear, and wing options in various widths and depths. The postformed/elliptical edge is not available in the laminate series when the front edge is curved. The postformed/elliptical edge shall be available on straight edged corner surfaces. The 90° diagonal corner worksurface will have a center round grommet as standard with T-mold edge. The curvilinear, dual curvilinear, and wing options will have rectangular shaped grommets as standard.

#### Countertops

The countertops shall be offered in widths of 24", 30", 36", 42", 48", 54", 60", 66", 72", 78", and 84" with a countertop depth of 16". Countertops shall also be available for 90° corner. Construction of the countertops shall be identical to the construction for the rectangular worksurfaces. The bracket to support the countertops shall consist of steel brackets and locking clips to prevent dislodgement. The brackets are mounted on the inside of the workstation allowing for a 4" extension over the top of the panel to conform with ADA guidelines. The countertops will also accommodate a task light.

#### Worksurface Support Panels

The support panels shall be available in the following sizes: 26" and 29" height and 24" and 30" depth. The worksurface support panel shall be 11/4" thick and constructed of 45-pound density particleboard with high-pressure laminate on both sides and high-pressure laminate on one side with fabric on the other side. The front edge of the high-pressure laminate panel shall be either a flat vinyl T-edge, 2mm PVC edge, or a postformed/elliptical edge. The worksurface support panel brackets shall prevent dislodgement from the vertical post of the panel. There shall also be an 18 gauge support bracket that attaches to the side of the support panel and to the underside of the worksurface.

#### Variable Height Front Surface Adjustment Mechanism

The variable height adjustment mechanism mounts underneath the dual curvilinear front worksurface and is available in black powder-coated finish only. The construction shall be steel construction finished in a durable black powder coat and offers front surface height adjustment and tilt. Height adjustment of 53/4" below and 7" above worksurface. Tilt adjustment of 9° positive and 15° negative. Mechanism has a 20# capacity spring assist for ease of adjustment.

#### Worksurface Grommets

Circular worksurface grommets, 23/4" I.D. and 3" O.D. shall be standard on T-edge worksurfaces. Trapezoidal shaped worksurface grommets 21/2" x 6" shall be standard on 2mm PVC edge, postformed/elliptical edge laminate. The worksurface grommet shall be a two-piece molded component with the ability to remove the top cover to allow full access to the grommet hole.

#### Worksurface Vertical Fillers

A worksurface vertical filler shall be available to fill the gap when one worksurface drops from the standard 29" down to an adjacent 26" secretarial typing height worksurface. Worksurface vertical fillers shall be available in 24" and 30" widths. The height of the worksurface vertical filler shall be 3". The construction of the worksurface vertical filler shall be 16 gauge steel, powder-coated to match the trim colors of the panel. The worksurface vertical filler shall be attached to the worksurface through the use of wood screws.

#### Center Drawers

A locking center drawer shall be available with a minimum size of 21/2" height, 177/8" width, and 17" depth. The center drawer shall be a one-piece molded design with ball-bearing slides.

## Technical Specifications

### OVERHEAD STORAGE AND ACCESSORIES

#### Overhead Cabinet Task Lights

Task lights which suspend from the shelf and overhead cabinet shall be available. The task light shall mount flush with the underside of the shelf and overhead cabinet. Task lights shall be offered in standard panel trim colors. The task light shall have a 9' cord. Task lights will be available with an electronic ballast. Options include a cool white lamp. Cords can be concealed by tucking between the reveal along tiles.

#### Low Shelf

The product shall be offered in widths of 24", 30", 36", 42", 48", 54", and 60". The overall dimensions of the end panels shall be 9-1/2" high and 14-1/2" deep. The shelf depth shall be 13-1/4". Each shelf shall include separate brackets which allow for either on- or off-module mounting. On-module shelf shall mount into slots in vertical posts. Shelf must be same width as the panel to which it is mounted. Off-module shelf shall mount into the integral track in the horizontal rail, allowing shelf to slide along track. The end panels shall be constructed of 14-gauge steel with a powder-coat finish. The shelf shall be an 18-gauge steel weldment with a powder-coat finish. The front edge of the shelf shall be a PVC extrusion that also provides space for a concealed flush mount task light.

#### Regular Shelf

The product shall be offered in widths of 24", 30", 36", 42", 48", 54", and 60". The overall dimensions of the end panels shall be 16-1/2" high and 14-1/2" deep. The shelf depth shall be 13-1/4". Each shelf shall include separate brackets which allow for either on- or off-module mounting. On-module shelf shall mount into slots in vertical posts. Shelf must be same width as the panel to which it is mounted. Off-module shelf shall mount into the integral track in the horizontal rail, allowing shelf to slide along track. The end panels shall be constructed of 14-gauge steel with a powder-coat finish. The shelf shall be an 18 gauge steel weldment with a powder-coat finish. The front edge of the shelf shall be a PVC extrusion that also provides space for a concealed flush mount task light.

#### Overhead Cabinet

The product shall be offered in widths of 24", 30", 36", 42", 48", 54", and 60". The overall dimensions of the end panels shall be 16-1/2" high and 14-1/2" deep. The shelf depth shall be 13-1/4". Each cabinet shall include separate brackets which allow for either on- or off-module mounting. On-module cabinet shall mount into slots in vertical posts. Cabinet must be same width as the panel to which it is mounted. Off-module cabinet shall mount into the integral track in the horizontal rail, allowing cabinet to slide along track. Door fronts shall be offered in steel, fabric, and laminate versions with a dual-durometer PVC extruded handle. The door front will operate on a rack and pinion gear system and will utilize a center lock mechanism. The door front will store recessed inside the cabinet with the handle exposed. The steel door front shall be of honeycomb core construction with a powder-coat finish. The construction of the fabric door front shall be identical to the steel door front except that the outer surface of the door front is covered with fabric. The laminate door front shall be high-pressure laminate covering a particleboard core.

#### Shelf Dividers

Shelf dividers shall be offered in the same color trim as the panels. The shelf dividers shall be powder-coated steel. Installation or removal shall be accomplished without the use of tools or fasteners.



## Technical Specifications

### PAPER MANAGEMENT ACCESSORIES

#### Wall Track

Wall track shall be available to allow for hanging of components onto an existing structural wall in the identical method as if the components were hung on Crescendo panels available in 30", 66", or 84" lengths. The wall track shall consist of a double slotted 16 gauge steel with powder-coat finish in the panel trim colors.

#### Markerboards

Markerboards shall be available in 32" height and 30", 36", 42", 48", 54", and 60" widths. The markerboard shall be constructed of painted aluminum framed units with a white porcelain painted marker surface. The markerboard surface shall be magnetic with an eraser and markers. The markerboards will mount in the vertical post rail slots of a panel the same width as the board or to wall track.

#### Tackboards

Tackboards shall be available in 12", 16", 30", and 48" heights and in 24", 30", 36", 42", 48", 54", and 60" widths. The tackboard shall be constructed of 3/4" industrial insulationboard covered with fabric. The mounting brackets shall be steel powder coated and attached to the coreboard with T-nuts and machine screws. Fabric shall be attached to the coreboard with staples.

#### Tool Rail

The tool rail shall be fabricated from a powder-coated aluminum extrusion with injection-molded plastic end caps. The tool rail shall be attached to the panel through the use of steel brackets. The tool rail shall support all paper management accessories.

#### Plastic Paper Tray

The legal and letter sized paper trays shall be of injection-molded plastic construction. The paper tray shall be supported by the tool rail.

#### Plastic Vertical Storage Unit

The diagonal storage unit shall be of injection-molded plastic construction. Three injection-molded and painted ABS dividers shall be able to be used in left or right positions. The diagonal storage unit shall be supported by the tool rail.

#### Telephone Caddy

The telephone caddy shall be available 8-1/2" wide by 2" high by 9-1/2" deep. Caddy shall be adjustable to accommodate a phone up to 10-3/4" deep. Caddy shall include three hooks for suspending from tool rail.

#### Accessory Tray

The accessory tray shall measure 9 1/2" wide by 2" high by 10" deep and include three hooks for mounting to tool rail. Tray shall have compartments to hold pencils, paper clips and miscellaneous items. Tray shall be suspended from tool rail or used freestanding on worksurfaces and shelves.

#### Pencil Cup

The pencil cup shall be 4" wide by 4" high by 3 1/2" deep. Cup shall provide for storage of pens, pencils, and highlighters. Two hooks shall be provided for mounting on tool rail.

# Crescendo

## Typicals

### TYPICAL WORKSTATION CONFIGURATIONS

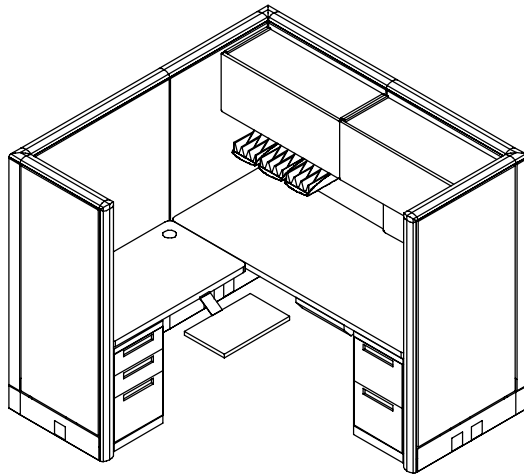
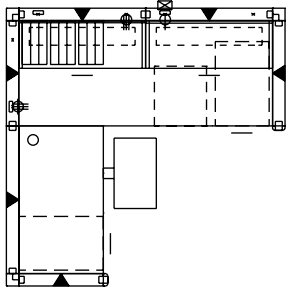

### Typical Clerk Workstation

WorkSpace: 36 sq. ft.

#### Workstation Features:

- Fabric Acoustical panels 66"H
- Base Electrical
- Laminate surfaces with flat vinyl T-edge
- Fabric overhead units with tasklights
- File/file and box/box/file pedestals
- Paper management accessories and tackboard
- Fully adjustable keyboard arm

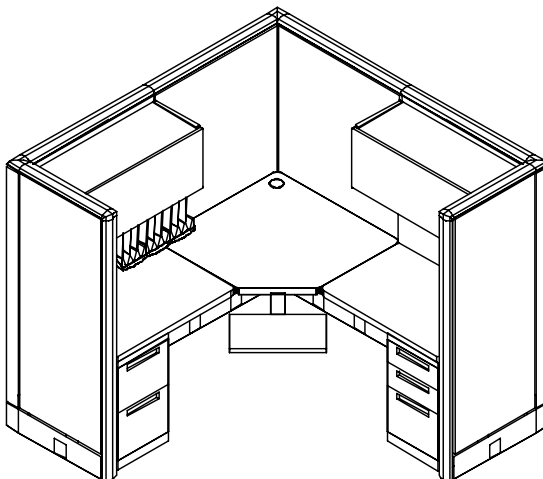
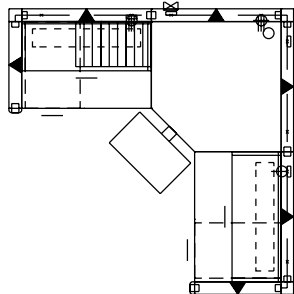

### Typical Assistant Workstation (66" Height Panels)

WorkSpace: 36 sq. ft.

#### Workstation Features:

- Fabric Acoustical panels 66"H
- Base Electrical
- Laminate surfaces with flat vinyl T-edge
- Fabric overhead units with tasklights
- File/file and box/box/file pedestals
- Paper management accessories and tackboard
- Fully adjustable keyboard arm

## Typicals

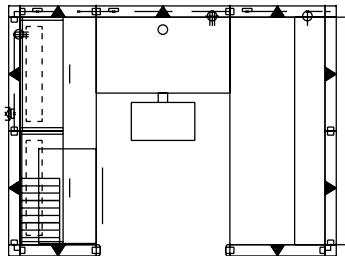
**Typical Receptionist Station**

WorkSpace: 48 sq. ft.

Workstation Features:

Fabric Acoustical panels 66"H  
 Base Electrical  
 ADA laminate countertop on 42" high panels  
 Laminate surfaces with flat vinyl T-edge  
 Fabric overhead units with tasklights  
 Fully adjustable keyboard arm  
 Two drawer lateral and box/box/file pedestal  
 Paper management accessories

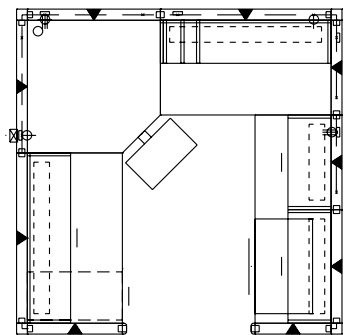
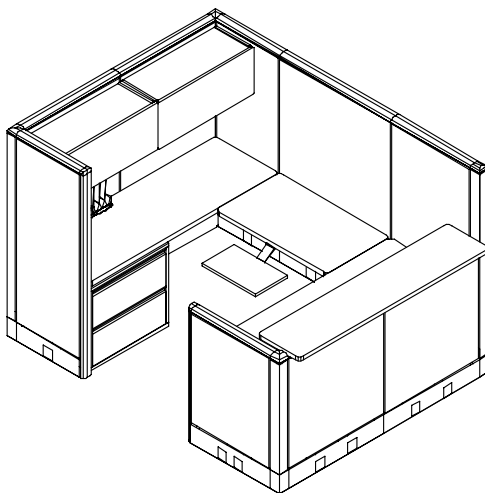
**Typical Engineer Workstation**

WorkSpace: 64 sq. ft.

Workstation Features:

Fabric Acoustical panels 66"H  
 Base Electrical  
 Laminate surfaces with flat vinyl T-edge  
 Fabric overhead units with tasklights  
 Open shelf with tasklight  
 Box/box/file pedestal  
 Lateral file  
 Tackboard and shelf dividers  
 Fully adjustable keyboard arm

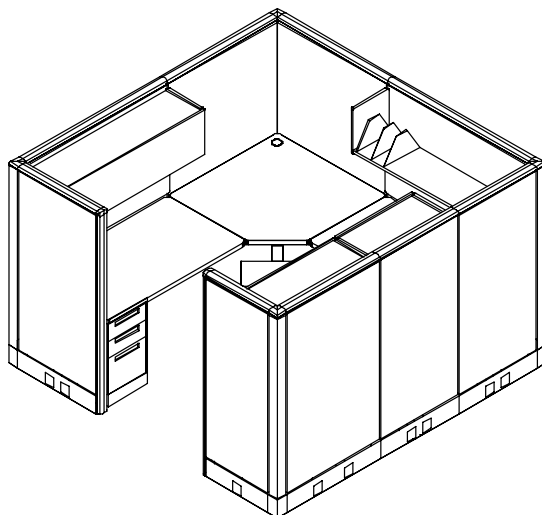

# Crescendo

## Typicals

### TYPICAL WORKSTATION CONFIGURATIONS

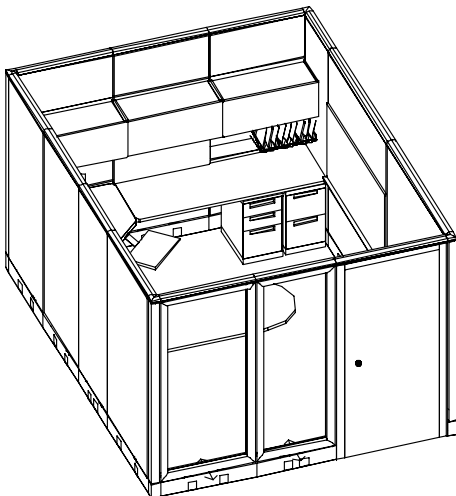
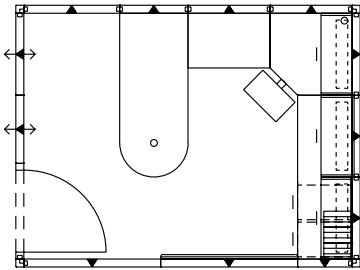
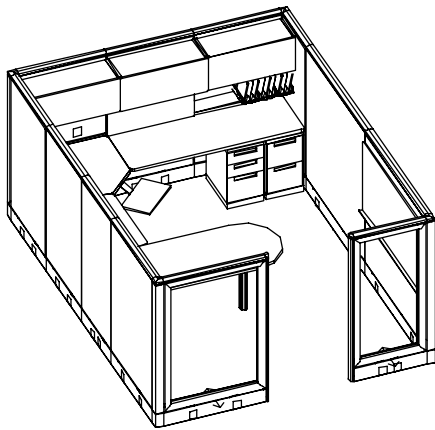
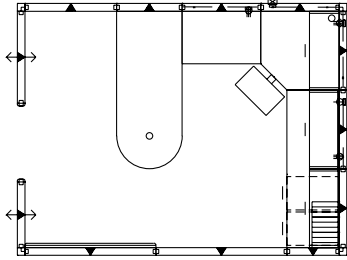

### Typical Manager Workstation (66" Height Panels)

WorkSpace: 108 sq. ft.

#### Workstation Features:

- Fabric Acoustical panels 66"H
- Base and Worksurface Electrical
- Laminate surfaces with flat vinyl T-edge
- Fabric overhead units with tasklights
- File/file and box/box/file pedestals
- Paper management accessories and tackboard
- Markerboard
- Fully adjustable keyboard arm

### Typical Manager Workstation (84" Height Panels)

WorkSpace: 108 sq. ft.

#### Workstation Features:

- Fabric Acoustical panels 84"H
- Laminate door 80"H
- Base and Worksurface Electrical
- Laminate surfaces with flat vinyl T-edge
- Fabric overhead units with tasklights
- File/file and box/box/file pedestals
- Paper management accessories and tackboard
- Markerboard
- Fully adjustable keyboard arm

## Typicals

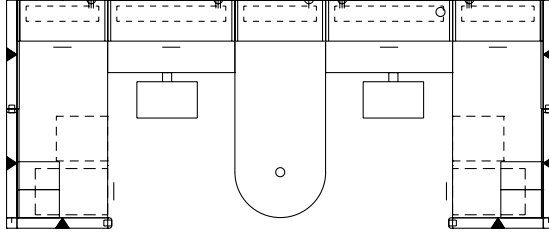
**Typical Shared Workstation**

WorkSpace: 87 sq. ft.

Workstation Features:

Fabric Acoustical panels 30"H, 42"H, 54"H, and 66"H

Base Electrical

Laminate surfaces with flat vinyl T-edge

Fabric overhead units with tasklights

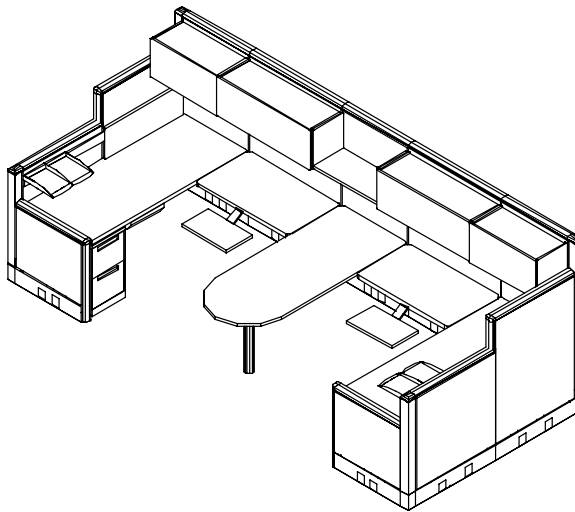



UNICOR  
320 First Street N.W. Building 400  
Washington, D.C. 20534  
800.827.3168  
[unicor.gov/ofg](http://unicor.gov/ofg) | [ofgsales@central.unicor.gov](mailto:ofgsales@central.unicor.gov)

CATPIEP100R1\_PDF0317